

OPERATORS & PARTS MANUAL

TD - SERIES TRACTOR BOX

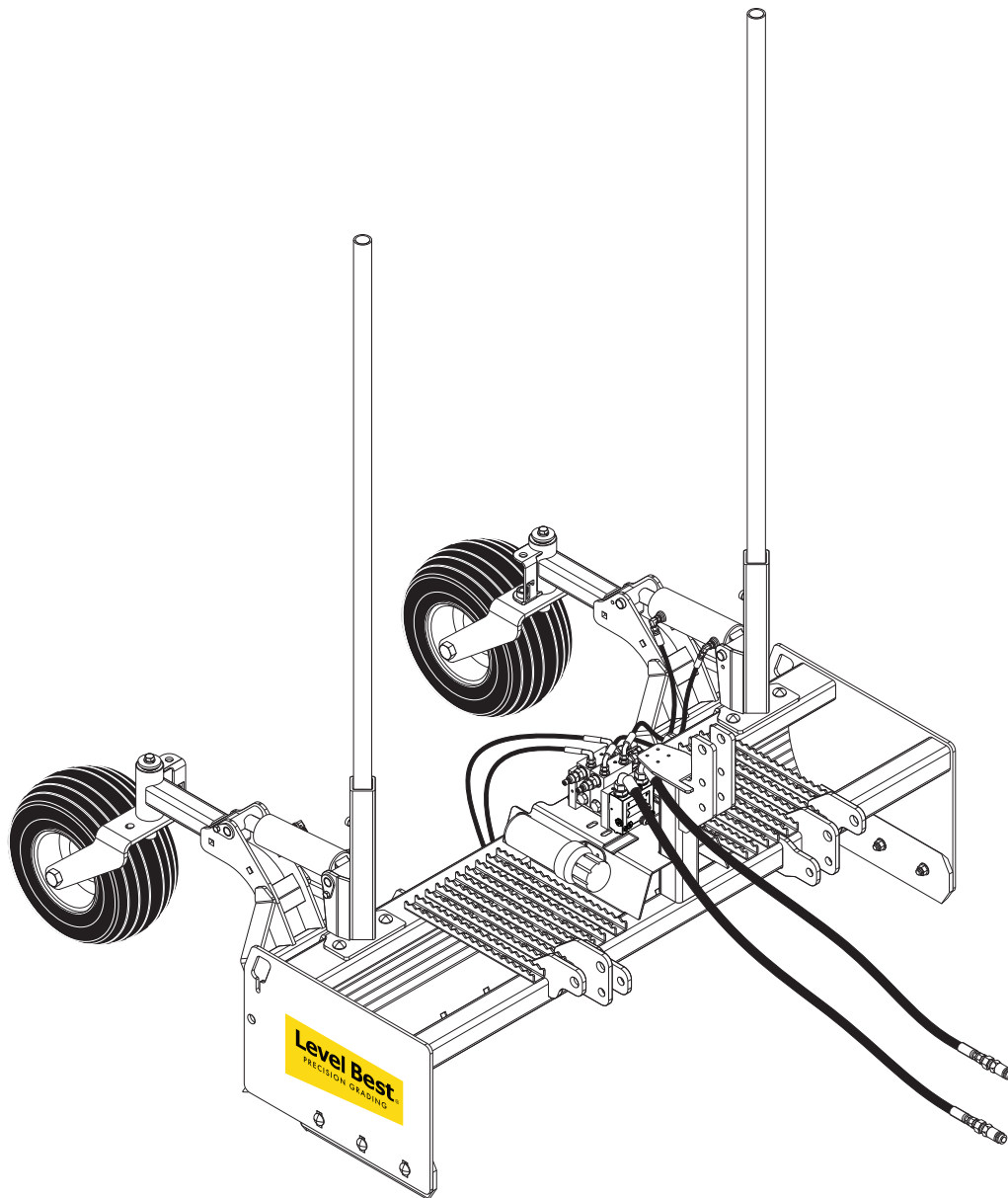

ATI Group, LLC
New Holland, PA 17557
1-800-342-0905
www.levelbestgrading.com

COPYRIGHT 2024 by
ATI Group, LLC
250 Earland Drive
New Holland, PA 17557 U.S.A.

DISCLAIMER

THE INFORMATION IN THIS MANUAL IS PROVIDED TO PROMOTE THE SAFE USE OF, AND ASSIST THE OPERATOR IN ACHIEVING THE BEST PERFORMANCE FROM, PARA-LEVEL GRADING BOX DESCRIBED HEREIN, FOR THEIR INTENDED APPLICATIONS.

NOTES

TABLE OF CONTENTS

Table of Contents	iii
Warranty.....	iv
Safety Information	v
Systems Features and Basic Operation.....	1.1
Apache/Spectra Controls	2.1
Troubleshooting.....	3.1
Parts Illustrations	4.1
Serial Number Information.....	4.2
Where To Get Parts and Service	4.2
How To Order Parts	4.2
List of Parts Illustrations.....	4.3
Index	5.1

WARRANTY

General Provisions. The warranties described below are provided by ATI Group LLC (“ATI”) to the original purchaser of new Level Best grading equipment (“Equipment”) from an authorized Level Best dealer. Under these warranties, ATI will repair or replace, at its option, any covered part which is found to be defective in material or workmanship during the applicable warranty term. Warranty service must be performed by a dealer or service center authorized by ATI to sell and/or service the type of Equipment involved, which will use only new or remanufactured parts or components furnished by ATI. Warranty service will be performed without charge to the purchaser for parts or labor. The purchaser will be responsible, however, for any service call and/or transportation of product to and from the dealer’s or service center’s place of business, for any premium charged for overtime labor requested by the purchaser, and for any service and/or maintenance not directly related to any defect covered under the warranties below.

What Is Warranted. All parts of any new Level Best grading equipment, except third-party machine guidance systems (which are warranted under their respective manufacturer’s warranty), are warranted for 36 months. The warranty term for all coverage begins at the time that any person, dealer, or agent first places a unit into service. At the latest, a unit is considered placed into service when delivered to an initial retail purchaser.

What Is Not Warranted. ATI is not responsible for the following:

- (1) Used Equipment;
- (2) Any Equipment that has been altered or modified in ways not approved by ATI;
- (3) Depreciation or damage caused by normal wear, lack of reasonable and proper maintenance, failure to follow operating instructions, misuse, lack of proper protection during storage, or accident;
- (4) Normal maintenance parts and service;
- (5) Economic loss including lost profit, equipment rental, or other expenses.

Securing Warranty Service. To secure warranty service, the purchaser must (1) Report the product defect to an authorized dealer and request repair within the applicable warranty term, (2) Present evidence of the warranty start date, and (3) Make the equipment available to an authorized dealer or service center within a reasonable time.

Limitation Of Implied Warranties and Other Remedies. To the extent permitted by law, neither ATI nor any company affiliated with it makes any warranties, representations or promises as to the quality, performance or freedom from defect of the Level Best Equipment covered by this warranty. IMPLIED WARRANTIES OF MERCHANTABILITY AND FITNESS FOR A PARTICULAR PURPOSE, TO THE EXTENT APPLICABLE, SHALL BE LIMITED IN DURATION TO THE APPLICABLE PERIOD OF WARRANTY SET FORTH ON THIS PAGE. THE PURCHASER’S ONLY REMEDIES IN CONNECTION WITH THE BREACH OR PERFORMANCE OF ANY WARRANTY ON THE LEVEL BEST EQUIPMENT ARE THOSE SET FORTH ON THIS PAGE. IN NO EVENT WILL THE DEALER, ATI, OR ANY COMPANY AFFILIATED WITH ATI, BE LIABLE FOR INCIDENTAL OR CONSEQUENTIAL DAMAGES.

No Dealer Warranty. The selling dealer makes no warranty of its own and the dealer has no authority to make any representation or promise on behalf of ATI, or to modify the terms or limitations of this warranty in any way.

SAFETY INFORMATION

This manual is furnished to you, the owner/operator, as a guide to get the greatest benefit from your Grading Box. ATI Group, LLC wants you to be able to get the most use out of your Grading Box through safe and efficient operation.

Before attempting to operate the Grading Box, carefully read all sections of this manual. Be sure that you thoroughly understand all of the safety information and operating procedures.

SAFETY PRECAUTION DEFINITIONS

Dangers, Warnings, Cautions, and Notes are strategically placed throughout this manual to further emphasize the importance of personal safety, qualifications of operating personnel, and proper use of the grading box in its intended application. These precautions supplement and/or complement the safety information decals affixed to the unit and include headings that are defined as follows:

DANGER

Indicates an imminently hazardous situation which, if not avoided, will result in death or serious injury.

WARNING

Indicates a potentially hazardous situation or practice which, if not avoided, could result in death or serious injury.

CAUTION

Indicates a potentially hazardous situation or practice which, if not avoided, will result in damage to equipment and/or minor injury.

NOTE: Indicates an operating procedure, practice, etc., or portion thereof, which is essential to highlight.

- Always use caution and safe operating practices when operating this equipment.
- Always set the Automatic/Manual Switch on the Control Panel to MANUAL before leaving the operator's seat or whenever the machine is not moving.

- Always allow for clearance under the cutting edge of the machine when tuning the system or when switching to automatic control. Insufficient clearance could cause the machine to lift itself off the ground as its cutting edge attempts to achieve the programmed slope.
- Never adjust the position of the Laser Receiver when the system is in automatic control.
- Never perform service work on your machine or the Automatic Control System when the system is in automatic control.
- Install all safety panels and guards before operating your equipment.
- Stay clear of all moving parts when the machine is in operation.
- Keep all people clear of the machine when it is running.
- Keep feet and other body parts from under the cutting edges of the machine at all times.
- Read and comply with all safety recommendations of your Tractor/Skid Steer manufacturer, as outlined in its operator and service manuals.

NOTE: References made to left, right, front, and rear are those directions viewed from behind the power unit and grading box.

NOTE: Some equipment depicted in illustrations may not reflect exact production model configurations.

NOTE: All safety, operating, and servicing information reflects current production models at the time of publication of this manual.

NOTE: ATI Group, LLC reserves the right to discontinue models at any time, change specifications, and improve design without notice and without incurring obligation on goods previously purchased and to discontinue supplying any part listed, when the demand does not warrant production.

(for future use)

SYSTEMS FEATURES AND BASIC OPERATION

SYSTEMS FEATURES AND BASIC OPERATION	1.1
List of Illustrations.....	1.2
Purpose	1.3
Components	1.3
Rotating Laser.....	1.4
Equipment Set-Up	1.4
Job Site Set-Up	1.6
Set-Up for Level Grading.....	1.6
Set-Up for Sloped Grading.....	1.6
Benching And Operating	1.8
Benching.....	1.8
Benching with a Rod Eye.....	1.9
Operation	1.9
Specifications and Maintenance	1.11
Specifications.....	1.11
Dimensions.....	1.11
Maintenance.....	1.11
Storage and Transport.....	1.11
Cleaning.....	1.11
Cables and Hoses.....	1.11
Machine	1.11
Calibration	1.12
Service	1.12

SYSTEMS FEATURES AND BASIC OPERATION

LIST OF ILLUSTRATIONS

Figure 1-1.	Plane of Laser Light with Components of the Automatic Control System	1.3
Figure 1-2.	Rotating Laser.....	1.4
Figure 1-3.	Control Panel Mounting	1.5
Figure 1-4.	Components of the Automatic Control System	1.5
Figure 1-5.	Method One: Align Rotating Laser with Grade Stakes	1.7
Figure 1-6.	Sight over Rotating Laser	1.7
Figure 1-7.	Grade Stake with Elevation Mark	1.7
Figure 1-8.	Method Two: Align Rotating Laser with Grade Stakes.....	1.8
Figure 1-9.	Lube and Maintenance Chart.....	1.13

SYSTEMS FEATURES AND BASIC OPERATION

PURPOSE

The Level Best Laser Grading Box is a cost-efficient method for fine grading. Various capacities sized to fit your tractor with a choice of Automatic Control Systems are available.

Laser-guided depth control provides unmatched measurement of plane from a single Rotating Laser. Grade information from the Rotating Laser is processed and automatically directs the grading box's hydraulics to maintain the elevation of the cutting edge.

The Laser Grading Box "rides" on gauge wheels at the rear of the frame. Each gauge wheel is attached to a hydraulic cylinder and "floats" independently of the other. By using a separate cylinder with an independent control system for each gauge wheel, the double-cylinder Laser Grading Box is able to provide a more accurate side-to-side grade than boxes with a single cylinder.

Grade Position LEDs on each Laser Receiver indicate the location of the box's cutting edge relative to the required finished grade (the Control Panel has a set of LEDs that mimic the Laser Receiver's LEDs).

In manual control, the operator watches the Grade Position LEDs and uses the box's controls to keep the center LEDs lit, thereby keeping the box "On Grade".

In automatic control, the Automatic Control System controls the box's hydraulic cylinders to keep the center LEDs lit, thereby keeping the box "On Grade". Each end of the cutting edge responds separately to the inputs appropriate Automatic Control System installed on that end.

COMPONENTS

The control system consists of 4 components:

Rotating Laser – Provides a reference Plane of Laser Light over the job site (refer to **Figure 1-1**). The light plane may be level or set at an angle to match the slope of the ground.

Laser Receivers – Mounted at a specific height on a mast on the Laser Grading Box, it determines the difference in depth based on the Plane of Laser Light.

Control Panel – Mounted on the tractor within easy reach of the operator, the Control Panel process data received from their connected Laser Receiver and from the operator. LEDs indicate the location of the box's cutting edge relative to the desired finish grade. If set to Automatic, it provides a signal to the Valve Assembly to either raise or lower the appropriate end of the Laser Grading Box.

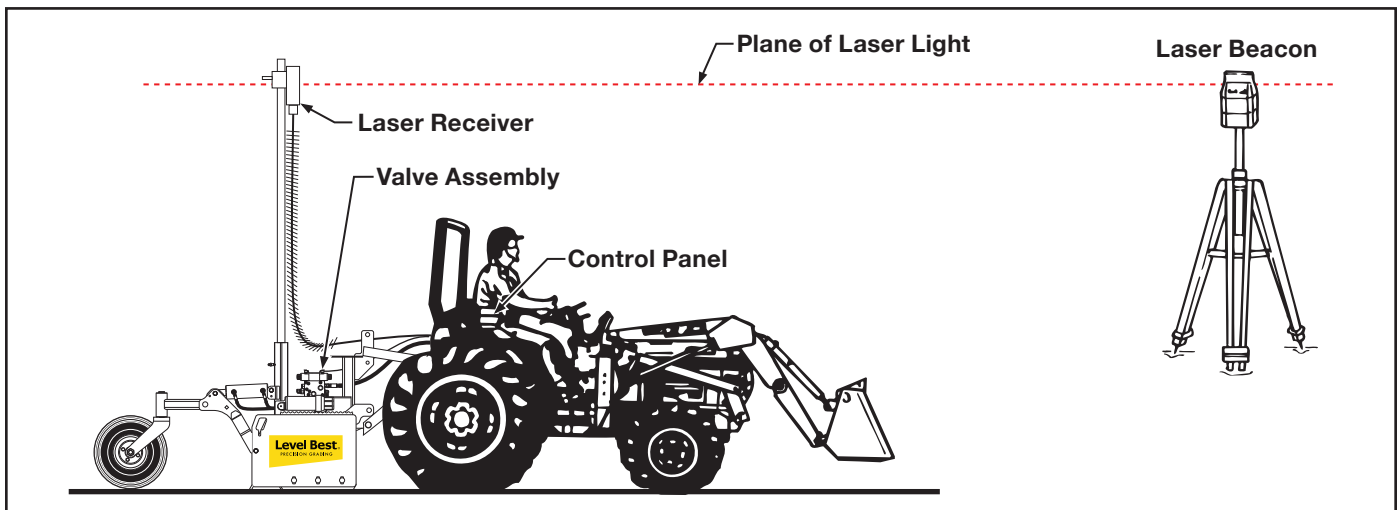

Figure 1-1. Plane of Laser Light with Components of the Automatic Control System

SYSTEMS FEATURES AND BASIC OPERATION

ROTATING LASER

The Automatic Control System can operate with many models of Rotating Lasers. The beacon must have a 360° rotating head with invisible or red beam and a speed of 8-40 RPS (Revolutions per Second). The faster the beacon's speed the more optimally the system will perform.

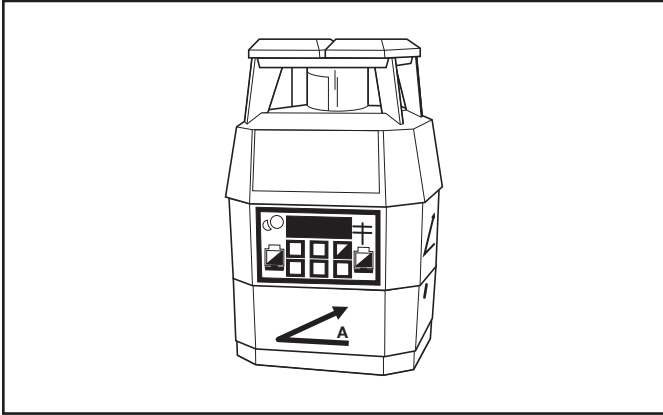

Figure 1-2. Rotating Laser

The Rotating Laser is mounted on a tripod, which is located on the job site near where the box is operating. The Rotating Laser is the unit that creates the plane of laser light detected by the Laser Receivers.

The Rotating Laser transmits a focused plane of laser light approximately 1000 feet (300 meters), optimal range for most Rotating Lasers, as it rotates.

Rotating Lasers are available in single grade, dual grade, and steep slope versions. They can be quickly and easily aligned to job site requirements without complicated calculation of angles.

A dual slope Rotating Laser can be configured for level, single slope, or dual slope applications. Simply enter the required percent of grade and align the Rotating Laser to the axis (direction) to be graded.

Percent of Grade. The change in elevation for every 100 feet (30 meters) graded.

Slope. The change in elevation per foot (meter).

⚠ WARNING

Never look directly into a laser light or serious injury to the eye may occur. In general, incidental exposure of the laser to the eye will not do damage. However, avoid looking into the beam whenever possible. Use a target for viewing the laser spot.

⚠ WARNING

Use of any laser on a worksite is controlled by OSHA regulations found at 29 CFR 1926.54. Be familiar with these regulations before using any laser beacon used in conjunction with this system. Review and understand all literature provided with the Laser System before operating.

⚠ WARNING

Laser protection devices must be provided to all workers in the area if the laser system exceeds five (5) milliwatts. Refer to the literature provided with the system to determine the power output. If unsure of the strength of the laser system, anti-laser eye protection should be provided to all workers.

EQUIPMENT SET-UP

1. Connect the Power Cable to battery power supply. Place the connector end of each cable near the driver's seat for later connection to the Control Panel.

NOTE: The red wire is positive and the black wire is negative.

2. Position the Laser Grading Box on a level area for attaching to the tractor. Start the tractor and back up to Laser Grading Box. Attach the unit with the hitch pins supplied.
3. After attaching, ensure the Laser Grading Box is level by adjusting the top link and lower link arms. The front of the Laser Grading Box (closest to tractor) should be approximately 1/2" higher than the rear of the Laser Grading Box which should be level with the ground. Turn off tractor.

SYSTEMS FEATURES AND BASIC OPERATION

4. Mount the Control Panel bracket on the right rear fender of the tractor using the necessary hardware (not supplied). Install the Control Panel on the bracket using the side knobs to secure the unit.
5. Connect the Laser Grading Box's hydraulic hoses with quick couplers to the tractor quick couplers. The Laser Grading Box's hydraulic manifold is marked with a "P" and a "T" where the pressure and return (tank) hoses enter.
6. Insert the two mast poles into the holders on each side of the Laser Grading Box until they rest on the bottom of tube and tighten the tee handle to secure. Clamp one Laser Receiver near the top of each Mast so it is higher than any local obstructions including the tractor cab or fall protection devices. (Refer to **Figure 1-4**).
7. Connect the 90° end of the Junction Block/Receiver cable to the Control Panel. Attach the Junction Block to the Tractor Fender using the included hardware.

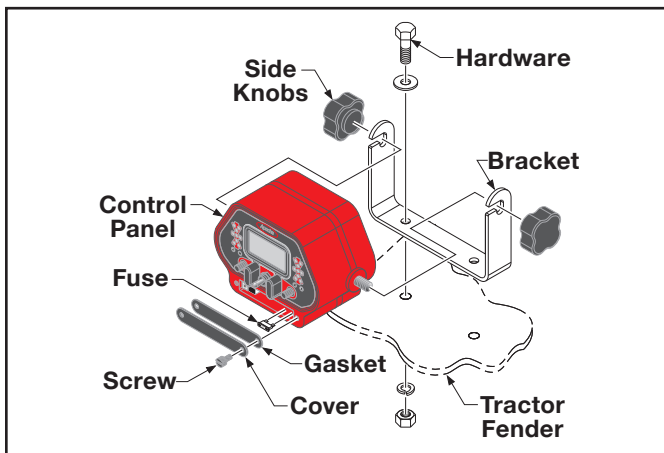

Figure 1-3. Control Panel Mounting

NOTE: "P" means pressure (supply) and "T" means tank (return). Refer to the Tractor Owner's Manual for identifying the "P" and "T" auxiliary hydraulic ports.

CAUTION

Do not connect left-side Laser Receiver to right-side valve or vice-versa.

NOTE: When connecting cables to the Control Panel, the left-side system must be connected together and vice-versa for the right side. If necessary, mark the Control Panel and associated cabling to ensure proper action during operation.

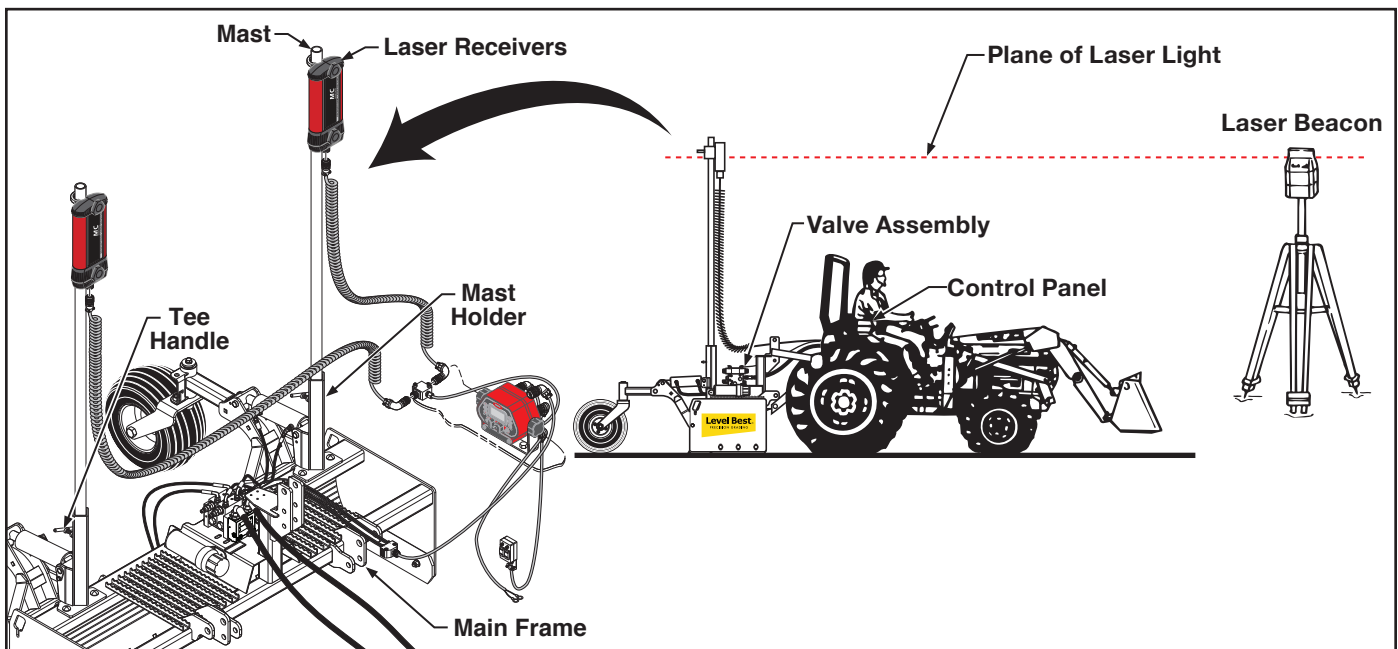

Figure 1-4. Components of the Automatic Control System

SYSTEMS FEATURES AND BASIC OPERATION

8. Connect the straight end of a Receiver Cable to the base of a Laser Receiver and the 90° end to the Junction Block. Be sure to connect the Left Receiver Cable to the Junction Block connector marked L. Connect the Right Receiver Cable to the Junction Block connector marked R.
9. Connect the straight ends (molded) of the Solenoid Cable to the directional valve solenoid (the connector for the Right valve is marked) and the 90° connector (10-pin) to the back of the Control Panel.
10. Connect the 90° connector end of the Power Cable to the back of the Control Panel. The terminal ends were previously wired to the battery.

WARNING

Always have the system in MANUAL when not operating the tractor.

JOB SITE SET-UP

The following are guidelines for setting up the Rotating Laser for both level job sites and sloped job sites:

Choose a location for the Rotating Laser where obstructions, such as trees and buildings, can not block the plane of laser light. The Laser Receivers need to be able to sense the plane of laser light at all times.

Whenever possible, set up the Rotating Laser and Laser Receivers at a height above the machine's cab. This prevents the cab or rollover structure from blocking the plane of laser light as the machine moves around the job sites.

The recommended head speed for the Laser Receivers is 20 RPS (Revolutions per Second). At 20 RPS, the Rotating Laser updates the Laser Receivers 20 times per second.

Set-Up for Level Grading

If the job site is to be level, the set-up of the Rotating Laser is simple. Since no slope is required in either axis, the Rotating Laser does not need to be aligned. The Rotating Laser will provide a level plane of laser light in all directions.

1. Locate the Rotating Laser following the previously stated guidelines.
2. Apply power to the Rotating Laser. Level the Rotating Laser (some Rotating Lasers will automatically level, others will need manual adjustment).
3. Set the counters for both axis at 0.000% (If needed, see the Rotating Laser Operation Manual).
4. Bench the machine. See the "Benching and Operating" procedure in this section.

Set-Up for Sloped Grading

If the job site is to be graded for a single or dual slope, the Rotating Laser requires its axis to be aligned for the job site. The Rotating Laser will then provide a plane of laser light at the required slope(s).

The following procedures are for two typical examples of job sites requiring sloped grades. Remember, each job site is unique, so consider the following methods as guidelines and not as the only methods possible.

Method One:

1. Set a minimum of two grade stakes exactly in line with one of the axis to be graded.
2. Place the Rotating Laser in line with the two grade stakes.
3. Switch on the Rotating Laser. Level the Rotating Laser (some Rotating Lasers will automatically level, others will need manual adjustment).
4. Set the counter on the Rotating Laser for both axis to 0.0000% (If needed, see the Rotating Laser Operation Manual).
5. Roughly align one of the axis to the grade stakes by sighting over the top of the Rotating Laser (Refer to [Figure 1-5](#)).

SYSTEMS FEATURES AND BASIC OPERATION

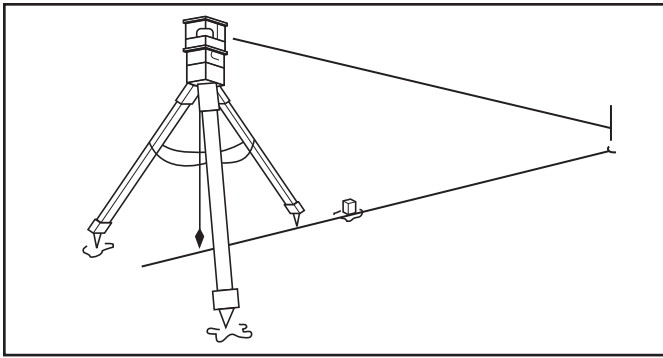

Figure 1-5. Method One: Align Rotating Laser with Grade Stakes

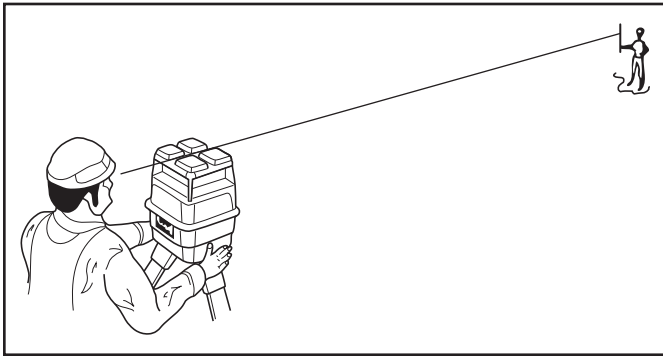

Figure 1-6. Sight over Rotating Laser

6. Align the plane of laser light.

Set a grade Rod with Rod Eye Receiver on the far grade stake and adjust the rod until the Rod Eye Receiver indicates “On Grade.”

On the axis not aligned with the stakes, enter on the Rotating Laser: 5.000%. Allow the Rotating Laser to level itself to this new position, if needed.

Check the Rod Eye Receiver again.

If the Rod Eye Receiver indicates “On Grade”, the plane of laser light is aligned correctly.

If the Rod Eye Receiver indicates the plane of laser light is too high or too low, have a second person rotate the Rotating Laser on the tripod in small steps until the Rod Eye Receiver indicates “On Grade.”

7. Enter on the Rotating Laser the required percent of grade for each axis and allow the Rotating Laser to level itself again.

8. Bench the machine. See the “Benching and Operating” procedure in this section.

Method Two:

1. Set a minimum of two surveyed grade stakes. The stakes must have elevation information (Refer to **Figure 1-7**).

NOTE: This procedure requires that the elevation of the grade stakes are correct and aligned to the slope or percent of grade required.

2. Place the Rotating Laser a few feet (meters) behind the first grade stake and in line with one of the far grade stakes (It is not critical to align the Rotating Laser exactly) (Refer to **Figure 1-8**).

NOTE: Follow the guidelines at the beginning of this section when placing the Rotating Laser.

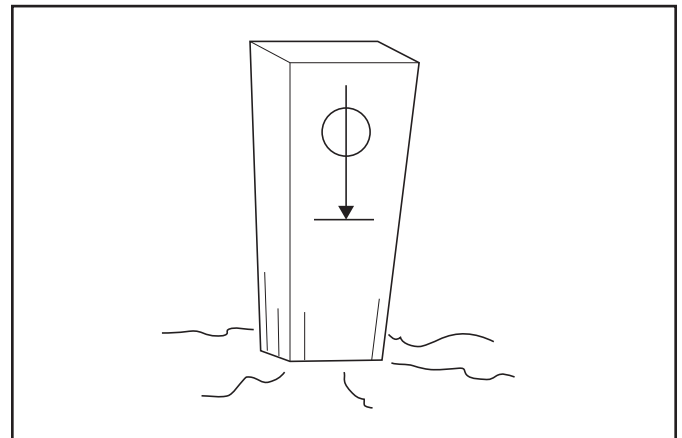

Figure 1-7. Grade Stake with Elevation Mark

3. Switch on the Rotating Laser. Level the Rotating Laser.
4. Roughly align one of the axis to the grade stakes by sighting over the top of the Rotating Laser (Refer to **Figure 1-5**).

SYSTEMS FEATURES AND BASIC OPERATION

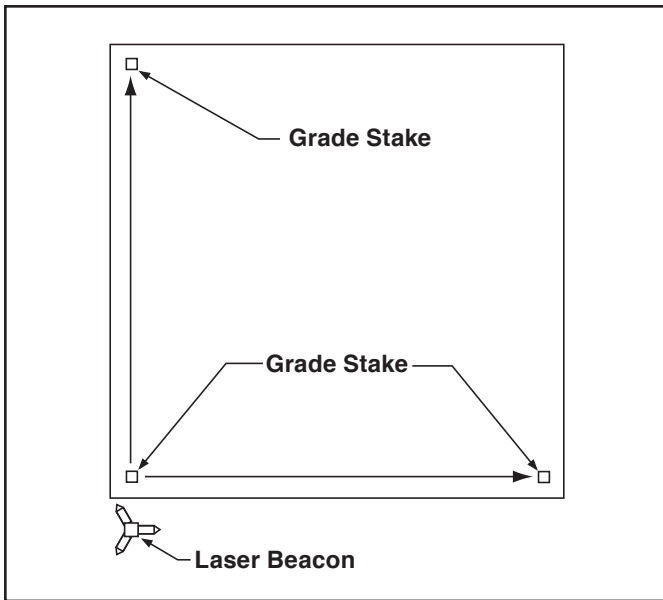

Figure 1-8. Method Two: Align Rotating Laser with Grade Stakes

5. Set both the counters on the Rotating Laser to the required percent of grade (If needed, see the Rotating Laser Operation Manual).

NOTE: The Grade Rod must be held plumb for each of the readings taken in the following steps.

6. Establish the H.I. (height of the instrument) for the plane of laser light.
 - a. Align the bottom of the Grade Rod to the mark on the near grade stake.

Adjust the Rod Eye Receiver up and down until it indicates “On Grade.”

Adjust the Rod Eye Receiver for any cut or fill amount indicated by the grade stake.

If the grade stake shows a cut, extend the Grade Rod and Rod Eye by the amount shown as a cut.

If the grade stake shows a fill, lower the Rod Eye by the amount shown as fill.

7. Align the plane of laser light.
 - a. Align the bottom of a Grade Rod to the mark on the far grade stake.

Check the Rod Eye Receiver.

If the Rod Eye Receiver indicates “On Grade,” the plane of laser light is aligned at the correct slope.

If the Rod Eye Receiver indicates the plane of laser light is too high or too low, have a second person rotate the Rotating Laser on the tripod in small steps until the Rod Eye Receiver indicates “On Grade.”

NOTE: If it was necessary to rotate the Rotating Laser a significant amount at the far stake, then the original reading at the near stake may be out of tolerance. Check the setting again and make minor adjustments as required.

8. Bench the machine.

NOTE: If needed, check the elevations on both the plane of laser light and the grade stake elevations by setting the bottom of the Grade Rod at any stake’s grade mark and checking the Rod Eye Receiver for the “On Grade” indication.

BENCHING AND OPERATING

Before benching, the plane of laser light must be set at its proper slope. Benching is the process of setting the relationship between the Laser Receivers and Rotating Laser, or benchmark. Failure to properly bench the system before grading will result in an unacceptable grade.

The goal is to have the Laser Grading Box approximately 1/2 full during operation. If, during rough grading, a lot of material needs to be removed from a site, the Laser Receivers should be set several inches higher than finished grade. As material is removed, the Laser Receivers can be lowered and the site regraded. This may need to be repeated several times until finished grade is achieved.

Benching

1. Move the machine to an area which is close to finish grade or, using the manual controls on the control system, grade a small area close to finish grade.

NOTE: Finish grade can be checked several times during the grade process to “zero” in on final grade.

2. Set the Auto/Manual Switches to MANUAL.

SYSTEMS FEATURES AND BASIC OPERATION

3. Turn the Laser Receivers and Rotating Laser ON.
4. Raise the Power switch and hold in the I position for 1 second to access the User Setup menu.
5. From the User Setup screen on the Control Panel, highlight the Deadband (Accuracy) icon and press the joystick.
6. Select the next to narrowest deadband setting.
7. Press the joystick twice to exit the deadband setup.
8. Adjust the height of the Laser Receivers until the center (On-Grade) Grade Position LED clusters are lit. The mast pole tee handle is NOT to be loosened, loosen the Laser Receiver clamp and move the Receiver on the mast pole.

NOTE: Most materials graded must later be compacted. To compensate for the compacting distance, lower both Laser Receivers equally. This raises the box's cutting edge by the same distance. The distance the Laser Receivers are lowered depends on the material.

Benching with a Rod Eye

To bench the Laser Receivers using a Rod Eye, follow the process listed below:

1. Turn on the Rotating Laser. Attach a Rod Eye to a measuring pole and turn on. Set the base of the measuring pole on the benchmark and adjust the measuring pole so the Rod Eye emits a solid "On Grade" tone (compensate for slab thickness and compaction if needed).
2. Find an area to be graded that is close to specified grade. Start the tractor, engage the auxiliary hydraulics and position the unit so one end of the cutting edge is in that location. Manually raise or lower the Laser Grading Box's cutting edge until it is even with the bottom of the measuring pole when the Rod Eye is emitting the "On Grade" tone or resting on the ground if already at grade.
3. Making sure the Control Panel's Automatic/Manual Switch is on Manual and the

On-Grade Deadband is set correctly (refer to steps 4 thru 7 in Benching) move the Laser Receiver to a height on the mast pole where it indicates the beam in the "On Grade" position and is unobstructed by any object.

NOTE: Operator may prefer to turn the face of the Laser Receiver towards the operator for easy viewing.

4. Repeat steps 2 and 3 for the other end of the cutting edge, moving either the machine or the measuring pole.

The Laser Grading Box Automatic Control System is now calibrated.

Operation

After the Laser Grading Box is connected and the Automatic Control System is calibrated, operation can begin.

The operational goal is to drive over the area to be graded with the box 1/2 full of material and the Control Panel's green light always illuminated.

1. When seated in the Operator's seat, start the tractor and set both Auto/Manual switches to AUTO.
2. Set the Deadband to a mid range setting.

NOTE: Most materials graded must later be compacted. To compensate for the compacting distance, lower both Laser Receivers an equally. This raises the box's cutting edge by the same distance. The distance the Laser Receiver is lowered will depend on the material.

3. Drive the machine forward. The Automatic Control System constantly senses the plane of laser light, raising and lowering each end of the grading box to maintain the cutting edge at the required elevation. Note the following during operation:
 - In some situations, the Automatic Control System may require a cut deeper than the

SYSTEMS FEATURES AND BASIC OPERATION

machine can handle. The machine may lose traction, stall the engine, or the wheel frame will be lifted off the ground to the maximum stroke of the cylinder as the cutting edge tries to reach finished grade. If this occurs, set the Auto/Manual switches to MANUAL and use the Raise/Lower switches to raise the cutting edge until the machine can push the material. Make multiple passes to cut the area closer to finished grade and then go back to AUTO control. This allows the high spots to be gradually removed.

- If one of the Control Panel's or Laser Receiver's grade lights are blinking, it indicates the direction of the last elevation prior to passing out of the laser beam. Readjust the height of the Grading Box manually until the signal is found. The Laser Receiver or Rotating Laser height may need to be adjusted if this situation continues to occur or switch to MANUAL operation until you get closer to grade.

NOTE: In rough grading situations, use the Automatic Control System as an "Indicate Only" system and operate the machine under manual control. After the area has been rough graded, switch to automatic control.

4. After several passes with the Laser Grading Box, stop and turn off the tractor. Place the base of the measuring pole on the graded area and check grade elevation.
5. After a rough grade is achieved, the On-Grade Deadband setting may be changed to a narrower setting as required to meet the job tolerance requirements. With a tighter deadband, the speed of the tractor needs to be decreased for optimum finish.

SYSTEMS FEATURES AND BASIC OPERATION

SPECIFICATIONS AND MAINTENANCE

SPECIFICATIONS

Dimensions

Model	TD60	TD72	TD84	TD96	TD108
Box Width	60 in. (153 cm)	72 in. (183 cm)	84 in. (213 cm)	96 in. (244 cm)	108 in. (274 cm)
Overall Width	61.8 in. (157 cm)	73.8 in. (187 cm)	85.8 in. (218 cm)	97.8 in. (248 cm)	109.8 in. (279 cm)
Total Length	69.7 in. (177 cm) 118 in. (300 cm) with optional drawbar				
Box Capacity	14.3 ft ³ (0.40 m ³)	17.0 ft ³ (0.48 m ³)	19.9 ft ³ (0.56 m ³)	22.8 ft ³ (0.65 m ³)	25.7 ft ³ (0.73 m ³)
Weight	930 lbs. (422 kg)	1060 lbs. (481 kg)	1200 lbs. (544 kg)	1320 lbs. (599 kg)	1565 lbs. (710 kg)

MAINTENANCE

The rugged and durable Automatic Control System is built to last, but as with all equipment, a few minutes of routine care, maintenance, and cleaning can extend the life of the system.

Storage and Transport

Most often the grading box and its hydraulic controls remain on your machine. However, you should store the Control Panel, Laser Receiver, Coiled Receiver Cable and Solenoid Cable in a safe place when not in use. Protect the cable connections by installing the covers supplied.

Cleaning

The Laser Receiver is completely sealed and purged with dry nitrogen. It requires no maintenance other than periodic checking to be sure its mounting structure is tight and secure.

The Control Panel is water resistant. It can be cleaned with mild soap and water, and a soft cloth. Do not submerge the Control Panel or direct high pressure spray at it. Do not use a dry cloth to wipe the Laser Receiver or Control Panel as scratching may occur.

Cables and Hoses

Check all cables and hoses regularly for signs of wear and damage. Keep cable connections clean and free from dirt and corrosion. If a cable has been damaged, do not attempt to repair. Incorrect or poor connections can cause damage to your Automatic Control System.

When applicable, check the hydraulic hoses. Look for areas where the hoses could rub against each other or another object as they expand and contract under pressure. Check the hydraulic fittings for tightness.

Machine

Check areas that affect the Automatic Control system function and accuracy, such as looseness or play in the cylinders or wear on the box's cutting edge. Looseness in the connection to the tractor, such as in the 3-point hitch, will cause inaccurate depth positioning.

Also check the tractor routinely for wear to its components, such as the 3-point linkage, ensuring it is operating properly.

Calibration

Perform periodic calibration checks of the Rotating Laser System, as outlined in its Operation Manual, to ensure accurate performance.

SERVICE

If the Automatic Control System is not functioning properly, the first step is to determine the problem component. Use the Troubleshooting Chart to determine possible causes and remedies. The following test equipment is needed:

Voltage/Ohm Meter

Rotating Laser or Laser Simulator

The Control Panel provides diagnostic codes to aid in troubleshooting and diagnostics. If a 5-digit code appears, contact ATI Group, LLC for assistance in diagnosing the code.

If the code 1505 appears, it indicates communication with the laser receiver(s) has been lost. Check the cable connections.

CAUTION

To prevent serious damage to the Automatic Control System, never replace a fuse with a fuse that has a higher amperage value.

CAUTION

The Automatic Control System is a highly sophisticated electronic system. Do not attempt repairs to the components. Contact your local dealer if you have any problems.

SYSTEMS FEATURES AND BASIC OPERATION

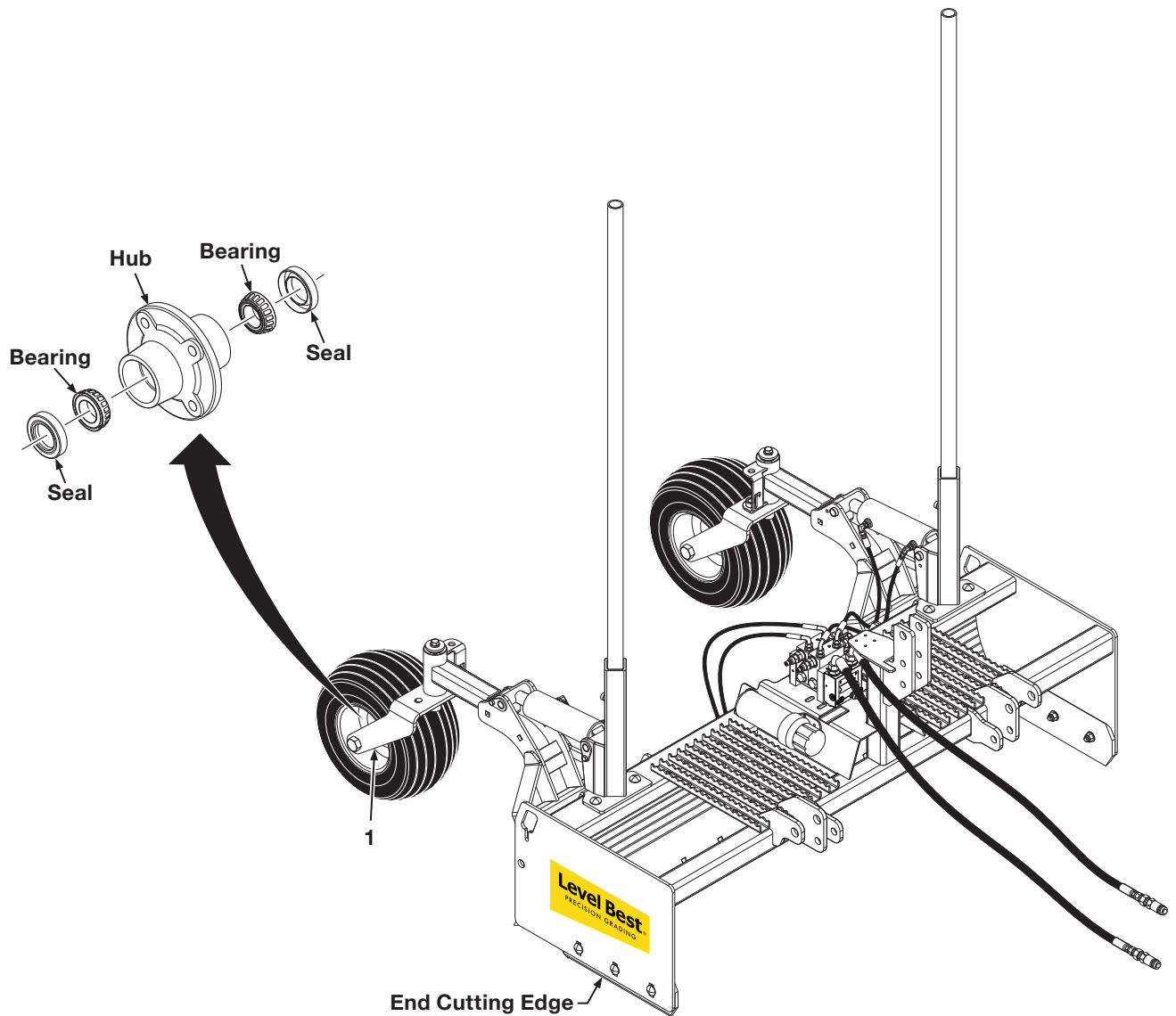

ITEM	NAME	FREQUENCY	LUBE TYPE
1.	Wheel Hub (2)**	Annually	EP*

* EP - Multi-Purpose Grease.
 ** Bearings must be pulled apart cleaned and packed once a year. Inspect grease seals and replace if necessary.

NOTES:

1. Check Hydraulic System Components for wear and/or leaks.
2. Check and tighten all bolts and nuts for cutting edge and end cutting edge, weekly.

Figure 1-9. Lube and Maintenance Chart

(for future use)

APACHE/SPECTRA CONTROLS

APACHE/SPECTRA CONTROLS	2.1
List of Illustrations.....	2.2
List of Tables	2.3
Notes	2.4
Control Panel	2.5
Controls	2.5
Operation	2.8
User Setup	2.9
Laser Receiver	2.12
Cables	2.13
Notes	2.15

APACHE/SPECTRA CONTROLS

LIST OF ILLUSTRATIONS

Figure 2-1. Control Panel Model CB52/CB30, Front View	2.5
Figure 2-2. Control Panel, Model CB52/CB30, Rear View	2.6
Figure 2-3. Control Panel Display	2.7
Figure 2-4. Receiver Position Indicator	2.7
Figure 2-5. LED Grade Display	2.8
Figure 2-6. User Setup Display Screen	2.10
Figure 2-7. LCD Brightness and Contrast Edit Mode	2.10
Figure 2-8. Deadband Edit Mode	2.10
Figure 2-9. Valve Speed Edit Mode	2.11
Figure 2-10. Reference Elevation Edit Mode	2.11
Figure 2-11. Units of Measure Edit Mode	2.11
Figure 2-12. Store and Recall Edit Mode	2.12
Figure 2-13. Laser Receiver, 5MC Front View	2.13
Figure 2-14. Receiver Junction Cable	2.14
Figure 2-15. Receiver Cable	2.14
Figure 2-16. Power Cable	2.14

LIST OF TABLES

Table 2.1. Units 2.11

APACHE/SPECTRA CONTROLS

CONTROL PANEL

The Control Panel is essentially a computer with built-in logic for the inputs and outputs connected to it. The Control Panel provides many adjustments to allow compatibility with different machinery and application requirements.

The Control Panel uses an LCD screen to provide information to the operator. The left side of the screen displays elevation, for the left side of the LGB and the right side is for elevation at the right-side of the LGB.

NOTE: This manual references the Tractor's ability to follow slope. This does not imply that a slope laser Receiver is required to provide this functionality. The tilt capability is obtained by measuring elevation at two different positions relative to the rotating laser.

The Control Panel has two modes accessible to the user; Operation and User Setup. In User Setup mode, items such as valve speed and LCD brightness can be adjusted. Operation mode allows operation of the LGB either automatically, with the Control Panel controlling depth, or manually, with the operator controlling the blade depth.

NOTE: The CB52/CB30 Control Panel can be configured several different ways. This manual assumes the ATI factory default setting displaying the left-side laser Receiver data, on the left side of the LCD and right-side laser Receiver data, on the right side of the LCD. Apache Technologies references this as dual elevation mode because both laser Receivers reference elevation and the LCD displays elevation data.

Controls

The CB52/CB30 Control Panel has joysticks (5 & 9) for operation of the raise, lower, functions and selection of automatic or manual control.

The following identifies the indicators, switches and type of switch on the Control Panel.

Front Control Panel Switches

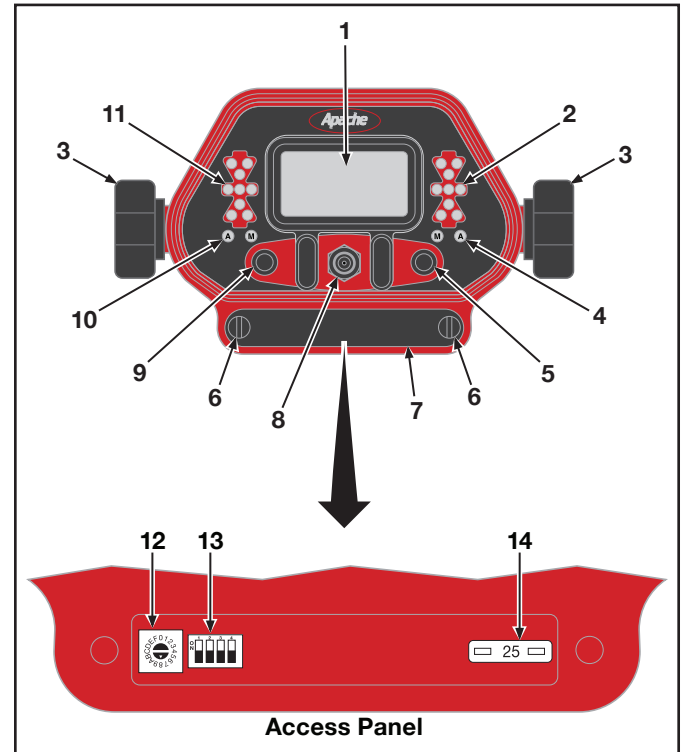

Figure 2-1. Control Panel Model CB52/CB30, Front View

LCD Display (1) – indicates the various operation and configuration modes. The items displayed change based on the mode and User Setup parameters chosen. Refer to the section on LCD display for more specific information.

LED Grade Display for Right-Side Elevation (2) – indicates where the cutting edge is in relation to the on-grade position. Refer to the section on Grade Indicators for more information.

Mounting Knobs (3) – secures the control panel to the mounting bracket.

Auto/Manual LED for the right-side (4) – green “A” LED illuminates when in Automatic operation and amber “M” LED illuminates when in Manual operation.

Right-Side Joystick (5) – left/right movement selects Auto/Manual control for the right-side and up/down movement raises and lowers the right side of the blade. Rotation increases/decreases the control setpoint. Pressing “in” enables elevation matching. When released, the joystick returns to a center, neutral position.

This joystick also navigates through the User Setup menus.

Access Panel Screws (6) – Retains access panel to the Control Panel.

Access Panel (7) – Panel contains a fuse, rotary switch and DIP switch used in factory setups.

Power Switch (8) – Turns power on and off. Also provides access to Help screens by pressing up while operating.

Left-Side Joystick (9) – left/right movement selects Auto/Manual control for the left-side and up/down movement raises and lowers the left side of the blade. Rotation increases/decreases the control setpoint. Pressing “in” enables elevation matching. When released, the joystick returns to a center, neutral position.

This joystick also navigates through the User Setup menus.

Auto/Manual LED for the left-side (10) – green “A” LED illuminates when in Automatic operation and amber “M” LED illuminates when in Manual operation.

LED Grade Display for Right-Side Elevation (11) – indicates where the cutting edge is in relation to the on-grade position. Refer to the section on Grade Indicators for more information.

CAUTION

Do not change or modify the Rotary or DIP switch positions. These switches are set at the factory before shipment. Contact the installation technician for additional information, if required.

Rotary Switch (12) – Used for factory setup. Do not adjust this unless directed to by ATI Group, LLC service department.

DIP Switch (13) – Used for factory setup. Do not adjust this unless directed to by ATI Group, LLC service department.

Fuse (14) – Automotive-style, 25 amp fuse protects against power surges.

Rear Control Panel Connections

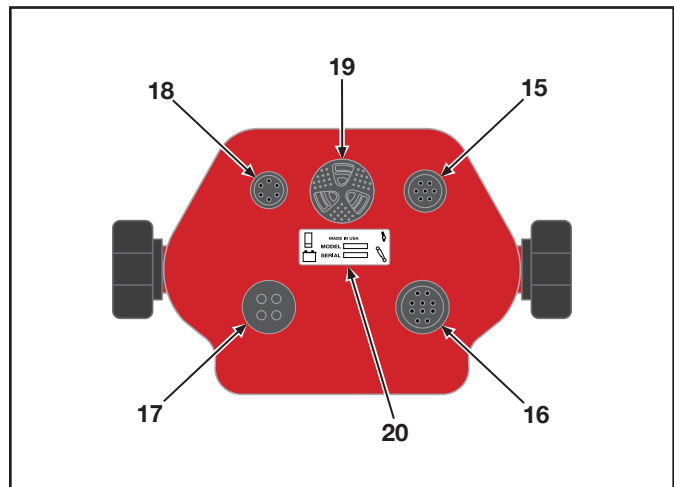

Figure 2-2. Control Panel, Model CB52/CB30, Rear View

Remote Switch (15) – 7-pin connector for the remote switch wire harness.

Hydraulic Valve Output (16) – 10-pin connector for the valve wire harness.

Machine Power Input (17) – 4-pin connector for the power wire harness.

Laser Receiver (18) – 7-pin connector for laser Receiver input. This connects to the junction box.

APACHE/SPECTRA CONTROLS

Beeper (19) – beeper for audible indication of alarms and switch engagement. A single beep is activated when a switch command is accepted. A double beep is activated when a selected function is not available or is incorrect. Beeper volume can be adjusted by rotating the beeper.

Serial Number Plate (20) – records build and model data for troubleshooting purposes.

Control Panel Display

The Control Panel Display provides information to the operator for efficient control of the LGB in either Automatic or Manual control. Inputs from the joystick located on the left side are displayed on the left side of the screen and vice-versa.

The default ATI Group, LLC setup of the control system displays data as two different elevations. Elevation information for the left laser Receiver is shown on the left side of the Control Panel LCD and elevation information for the right laser Receiver is shown on the right side of the LCD.

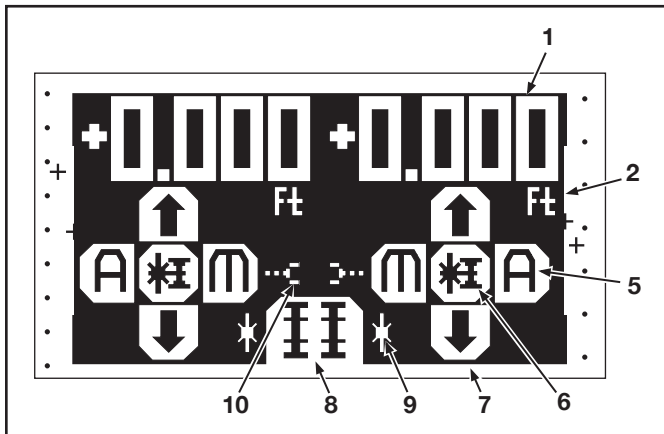

Figure 2-3. Control Panel Display

Reference Elevation (1) – indicates the reference elevation. The value is referenced from the last bench mark.

Units (2) – displays the units of the reference elevation. Can be changed in User Setup mode.

Receiver Position Indicator (3) – indicates the elevation relative to the vertical reception range of the receiver. The + indicator blinks when reception is lost.

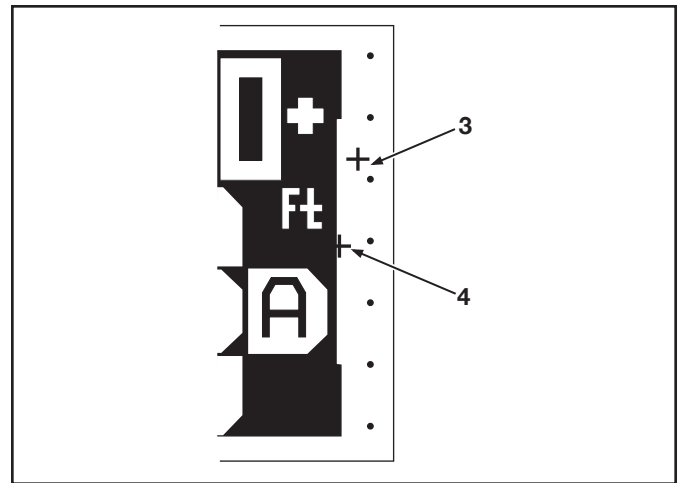

Figure 2-4. Receiver Position Indicator

The on-grade set range will vary depending on the width of the deadband. The smaller the deadband, the larger the range. The larger the deadband, the smaller the range.

Control Setpoint (4) – indicates where on-grade is set relative to the vertical reception range.

Automatic/Manual Indicator (5) – indicates if the control system is in manual (M) or automatic (A) mode.

Joystick Function Icon (6) – indicates the current mode of the joystick. Pressing the joystick alternates control between slope matching/benching and slope control setpoint.

Raise/Lower Indicator (7) – indicates the direction of movement of the blade.

Operating Mode Indicator (8) – indicates the operating mode of each side of the Control Panel. Dual elevation control is shown.

Control Source Indicator (9) – indicates the source of control. Starburst icon indicates input is being received from a laser receiver.

Linked/Unlinked Elevation Mode (10) – only used in dual elevation mode.

Grade Indicators

On each side of the LCD is a grade indicator. The grade indicator is a set of red and green LEDs that indicate relative position to grade. When a laser is striking the Receiver, there are 5 possible positions of grade information indicated.

APACHE/SPECTRA CONTROLS

High Coarse - 3 top red LED's forming down arrow.

High Fine - 3 top red LED's and 3 green on-grade LED's.

On-Grade - 3 green LED's forming horizontal bar.

Low Fine - 3 bottom red LED's and 3 green on-grade LED's.

Low Coarse - 3 bottom red LED's forming up arrow.

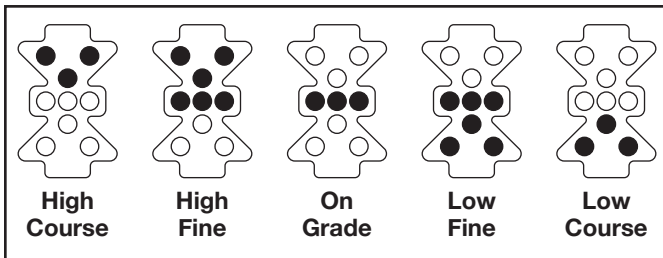

Figure 2-5. LED Grade Display

If the laser moves off the reception range of the Receiver, an out-of-beam will be indicated on the LEDs. If the last laser reception was on the bottom of the Receiver, the top 3 LEDs will flash indicating to move the Receiver down. If the last laser reception was on the top, the bottom 3 LEDs will flash indicating to move the Receiver up. The out-of-beam indication lasts for 2 minutes.

OPERATION

Control of the Laser Grading Box is accomplished through the Control Panel. The operator places the system in either Automatic control, where the system raises/lowers/tilts the LGB based on inputs from the laser system, or Manually, where the operator moves the LGB using the controls on the Control Panel.

WARNING

Always turn the system to manual before leaving the tractor. Move both joysticks toward the middle (inward) to activate manual mode.

To turn the system on, toggle the Power switch to the I (on) position. The LEDs and LCD will light to confirm power. The Control Panel will perform a diagnostic check to ensure the system components are present and responding correctly.

If the laser Receivers are present, the LEDs on the Receivers will light as a system check. If components are not found, a “No Receivers Found” message is displayed.

NOTE: The system must be restarted if Receivers or components are connected/added.

Automatic/Manual Control



To place the LGB under Automatic control, move the left joystick to the left (outward) and the right joystick to the right (outward) and release each to neutral. The green “A” LEDs on the Control Panel will light to indicate Automatic control.

Under Automatic control, the Control Panel sends the appropriate signals to the valve to raise and lower the LGB to obtain and maintain an on-grade position. If the Receiver is outside the range of the laser signal, it must be moved within range to start receiving signals.

To place the LGB under Manual control, move the left joystick to the right (inward) and the right joystick to the left (inward) and release each to neutral. The amber “M” LEDs on the Control Panel will light to indicate Manual control.

Under Manual control, the LED Grade Display will indicate grade information but will not send adjustment signals to the valve. Adjustment of the LGB elevation and slope can be accomplished manually.

Raise/Lower



The left-side joystick raises or lowers the left side of the LGB when under Manual control.

Move the joystick up to raise the blade and down to lower the blade.

When under Automatic control, the left-side joystick will temporarily raise or lower the left side of the LGB. When the joystick is released, the LGB returns to Automatic control.

The raise and lower functions are duplicated for the right side of the LGB by the right-side joystick.

APACHE/SPECTRA CONTROLS

Elevation Offset (Reference Adjustment)



The CB52 has the capability to adjust the on-grade point without adjusting the laser Receiver(s) to within one inch of the end of its range. This feature can be used to raise the grade for initial rough-cut and then return the LGB to desired grade for finishing.

The on-grade reference point is adjusted from the Control Panel by rotating the appropriate joystick. Rotate the joystick clockwise increases the elevation, counterclockwise decreases the elevation. The offset will not go beyond a limit programmed into the laser Receiver.

When the reference is adjusted, the LCD displays the actual elevation change from the benchmark.

If linking is enabled, either joystick can be rotated and the on-grade reference is adjusted equally for both sides. When under Automatic control, the LGB will begin to move immediately. When under Manual control, the blade will not move until placed under Automatic control.

Elevation



Elevation matching allows the current laser signal to be temporarily set to the on-grade reference. This allows adjustment of the on-grade elevation for an initial cut of the area to be graded at a set distance above the engineered plane.

When the laser strike signal is within range of the laser Receiver and at least one inch from the outer limit, press and hold the appropriate joystick for approximately 1 second and release when a single beep is heard from the Control Panel. The LCD and grade LEDs will indicate the LGB is on-grade. If outside the acceptable laser Receiver range, two beeps are sounded to indicate the command was not accepted.

To reset the elevation to the default center on-grade position, press and hold the joystick for five seconds. The first beep is heard at approximately one second and the second beep is heard at 5 seconds, when the elevation is reset to the default. The

elevation control setpoint returns to the center position and the LCD indicates the elevation in relation to the default.

Link

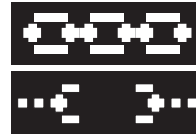

The Link capability within the Control Panel allows the two different elevations of the LGB to be adjusted/moved simultaneously. When activated, this function applies to changing Automatic/Manual control, adjusting elevation offset, and adjusting or resetting the elevation matching features.

Before linking, set the LGB in the desired position to ensure the relative positioning of the two laser Receivers. This is usually parallel to the laser plane. With the Control Panel in dual elevation mode (default), move both joysticks inward (manual position) and hold for 3 seconds. The link icon on the LCD will change from a broken link to a connected link (chain).

Audio Alerts

The beeper on the back of the Control Panel can be rotated to adjust the volume of the tones emitted.

A single, short beep is sounded to indicate an input, or command, is accepted. A double beep indicates a command was not accepted. A triple beep is sounded when the Control Panel is first powered up.

User Setup

When purchased from ATI Group, LLC, the control system is setup specifically for the unit purchased. Some items may be customized to suit the operator's specific needs or operating conditions. Up to three separate configurations can be saved. A fourth configuration returns the unit to the factory default settings.

To access the User Setup screen, hold the Power switch in the UP position for 1 second. When the setup screen appears on the display, release the switch. The Control System automatically enters manual mode when the User Setup screen is accessed.

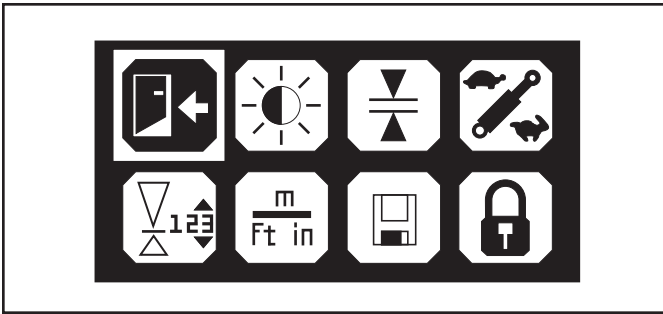

Figure 2-6. User Setup Display Screen

The User Setup screen has eight icons. The various icons and setup functions are accessed via either the joystick, rotating or moving the switch until the desired function is highlighted. Press either joystick to enter the selected function.



To return to the Operation screen, highlight the Return icon and press either joystick.

NOTE: Help screens are available within each function. Hold the power switch in the up position to access the help screen.

LCD Brightness and Contrast



Using the joysticks, highlight the LCD icon and press a joystick to enter the Brightness and Contrast edit mode. When in edit mode:

The left side indicates the brightness level and ranges from 5 to 100. Rotate the left-side joystick clockwise to increase the brightness level and counterclockwise to reduce the brightness level. Changes are made in increments of 5.

The right side indicates the contrast level and ranges from 0 to 100. Rotate the right-side joystick clockwise to increase the contrast and counterclockwise to reduce the contrast. Changes are made in increments of 1.

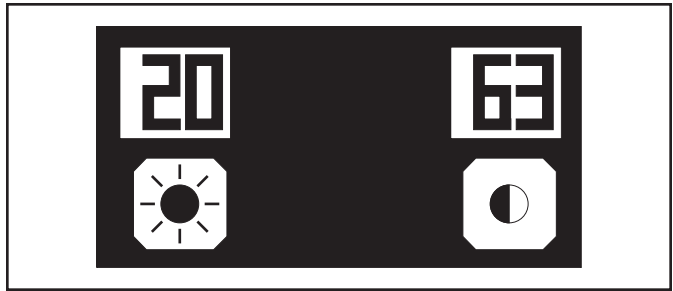

Figure 2-7. LCD Brightness and Contrast Edit Mode

Deadband (Accuracy)



Deadband refers to how tight a tolerance, or accuracy, is desired. Although a greater accuracy is normally desired, if the system becomes unstable, overreacting between above grade and below grade, the deadband should be increased to minimize overreaction.

Using the joysticks, highlight the deadband icon. Press a joystick to enter the Deadband edit mode.

When in edit mode, the left side of the LCD displays the elevation deadband in ft. The maximum elevation deadband is 0.170 ft. (2.00 in.). Rotating the left-side joystick changes the deadband for the elevation.



Setting the Deadband too narrow may cause the Grading Box to become unstable. If this happens, increase the deadband or decrease the valve speed.

NOTE: Adjustment is for display deadband. Default control deadband is the same but may be set smaller during installation.

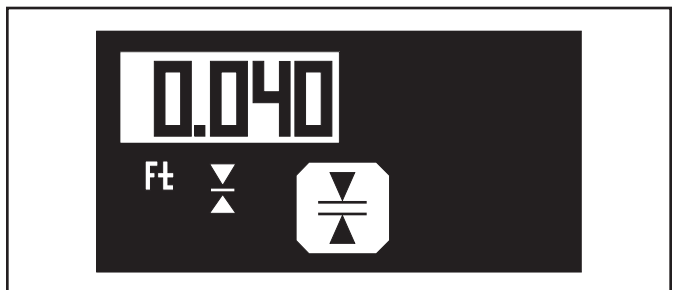

Figure 2-8. Deadband Edit Mode

APACHE/SPECTRA CONTROLS

Valve Speed



Valve speed relates to gain, or the speed at which the control system adjusts the LGB. When operating in sandy or loose materials, decrease the valve speed for slower hydraulic speed. When operating in clay, dirt or tighter materials, increase the valve speed for a faster hydraulic speed. If the system becomes unstable, overreacting between above grade and below grade, decrease the valve speed.

Using the joysticks, highlight the valve speed icon. Press the joystick to enter the valve speed edit mode. When in edit mode a single number appears, indicating the valve speed as a percentage between 0 and 100%.

Rotate either joystick to adjust the valve speed. The factory default is 50%.



Figure 2-9. Valve Speed Edit Mode

Reference Elevation



This sets a reference elevation, displayed on the edge of the operation mode display.

Using the joysticks, highlight the reference elevation icon. Press the joystick to enter the reference elevation edit mode. When in edit mode a single number appears on the left side of the display indicating the overall range of the display in operating mode. The units shown reflect the units selected.

Rotate the left-side joystick to adjust the range.

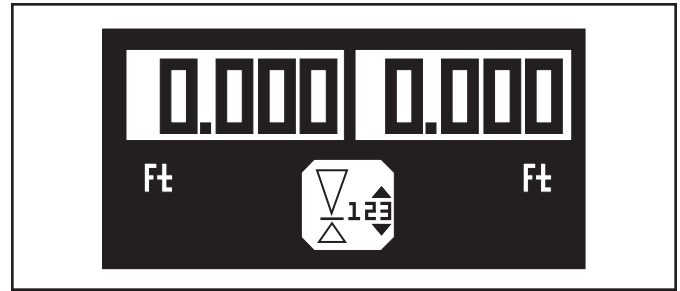

Figure 2-10. Reference Elevation Edit Mode

Units of Measure



The units used to display information to the operator can be changed.

Using the joysticks, highlight the units of measure icon. Press the joystick to enter the edit mode. When in edit mode, the currently selected units appear.

To adjust the elevation units, displayed on the left side of the screen, rotate the left-side joystick.

To adjust the slope units, displayed on the right side of the screen, rotate the right-side joystick.

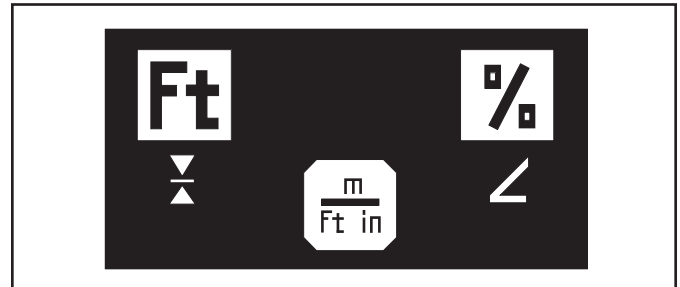

Figure 2-11. Units of Measure Edit Mode

The available units are shown in [Table 2-1](#).

Table 2-1: Units

Elevation		Slope	
Display	Units	Display	Units
Ft	feet	%	Percentage of slope
in	inches	°	Degrees of slope
m	meters		

Store and Recall Setup



This allows the operator to store three different setup configurations for future recall.

Using the joysticks, highlight the store and recall configuration icon. Press the joystick to enter the edit mode. When in edit mode, the left-side display and joystick manages the store function and the right-side display and joystick manages the recall function. Checksum values are also displayed to check copied setups.

To store the current configuration, rotate the left-side joystick to the desired number on the display. When selected, press the joystick to store the setup configuration. A message appears asking "Do you want to store?" Select YES to store and NO to return to the previous menu.

When YES is selected, a new name can be entered. Rotate the left-side joystick to scroll through the character choices. Move the joystick to the right to move to the next character. Up to 7 characters may be entered. Once entered, the named setting appears on the store and recall screen for future selection.

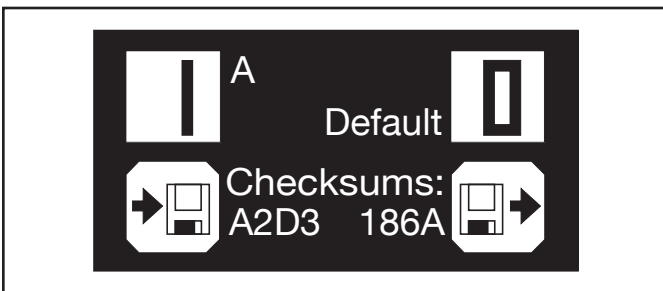

Figure 2-12. Store and Recall Edit Mode

To recall a saved configuration, rotate the right-side joystick to scroll through the selections. Highlight the desired configuration and press the right-side joystick to select it. A message appears asking "Do you want to recall the setup?" Select YES to recall and make the stored configuration the current configuration. Select NO to return to the previous menu.

Lock Setup



The current settings can be locked so changes to certain settings cannot be made without unlocking.



Using the joysticks, highlight the lock icon. Press the joystick to lock the configuration. The icon changes to indicate it is locked.

When locked, the following settings cannot be changed:

- deadband
- valve speed
- elevation and slope matching reference
- elevation values
- units of measure
- store and recall settings
- link sides

If changes are attempted to these settings, a "Locked" message appears on the screen.

LASER RECEIVER

The Apache B5MC Laser Receiver is a rugged, 360° electronic Receiver that detects laser light generated by rotating lasers. The unit is designed to work with all common rotating laser beacons and detects both visible and invisible beams.

The Receiver does not have any on-board switches, All settings are made on the Control Panel. Power to the B5MC Receiver also comes from the Control Panel. A small, built-in LED display provides grade elevation position, plus high and low lost beam indication.

APACHE/SPECTRA CONTROLS

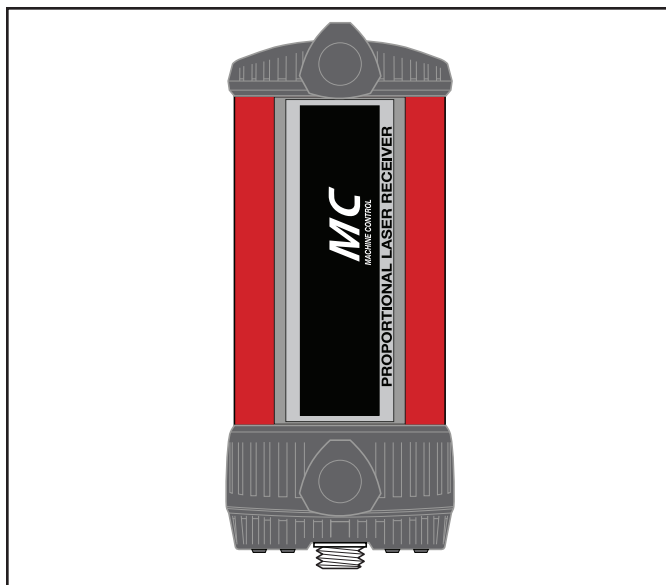

Figure 2-13. Laser Receiver, 5MC Front View

The Laser Receiver is mounted on the mast pole directly above the cutting edge of the box. The Receiver is the unit that detects the plane of laser light produced by the Rotating Laser. The Laser Receiver sends to the Control Panel the location of the plane of laser light. The Control Panel then has the valve assembly drive the Grading Box's hydraulics accordingly.

CABLES

Cables are provided to connect the various components together into a system. Each connector uses a unique number of pins or sockets to prevent the components from being connected incorrectly.

⚠ CAUTION

Never force a connector into a socket.

⚠ CAUTION

All cables must be secured with adequate cable length to avoid pinching, stretching and tight bending. Do not clamp cables to pipes or hoses that may generate high heat.

Cable Configurations:

Receiver Cables - powers the Receiver and communicates grade information between the Laser Receiver and Junction Block. The Junction Block end uses a 90° connector to differentiate it from the

Laser Receiver end. This is a coiled cable that can hang freely between the Junction Block and Laser Receiver mounted on the mast.

NOTE: The Junction Block is marked L & R for the Left and Right Receiver Cables.

Power Cable - supplies power to the system. The Control Panel supports both 12 and 24 volt machine systems.

NOTE: The Control Panel supports both 12 and 24 volt machine systems. However, the valve is 12 volt only. Contact ATI Group, LLC for additional information when using a 24 volt system.

Junction Block/Receiver Cable - provides a connection method for two Receiver cables and the one connector on the Control Panel. The junction block end of the cable attaches to the Control Panel mounting bracket.

Information from each laser Receiver is coded to identify the Receiver and, when the information is received, the Control Panel decodes the signals. This allows the signals to be passed to the Control Panel through a single connector.

Valve Cable - communicates grade information between the Control Panel and the hydraulic valve. There is one connector for the Control Panel and two connectors for the valve. One connector goes to each valve solenoid. Labels located on the cable identify the solenoid to connect to.

Valve Assembly

The valve assembly is an aluminum block manifold with two electrically-actuated valve sections. The valve actuates the cylinders, raising and lowering the gauge wheels, based on input from the Control Panel.

When connecting, the left side of the Control Panel and left side Laser Receiver must be connected to the left side valve and the right side of the Control Panel and right side Laser Receiver must be connected to the right side valve.

NOTE: Left and right sides are determined as if sitting in the tractor seat facing forward.

APACHE/SPECTRA CONTROLS

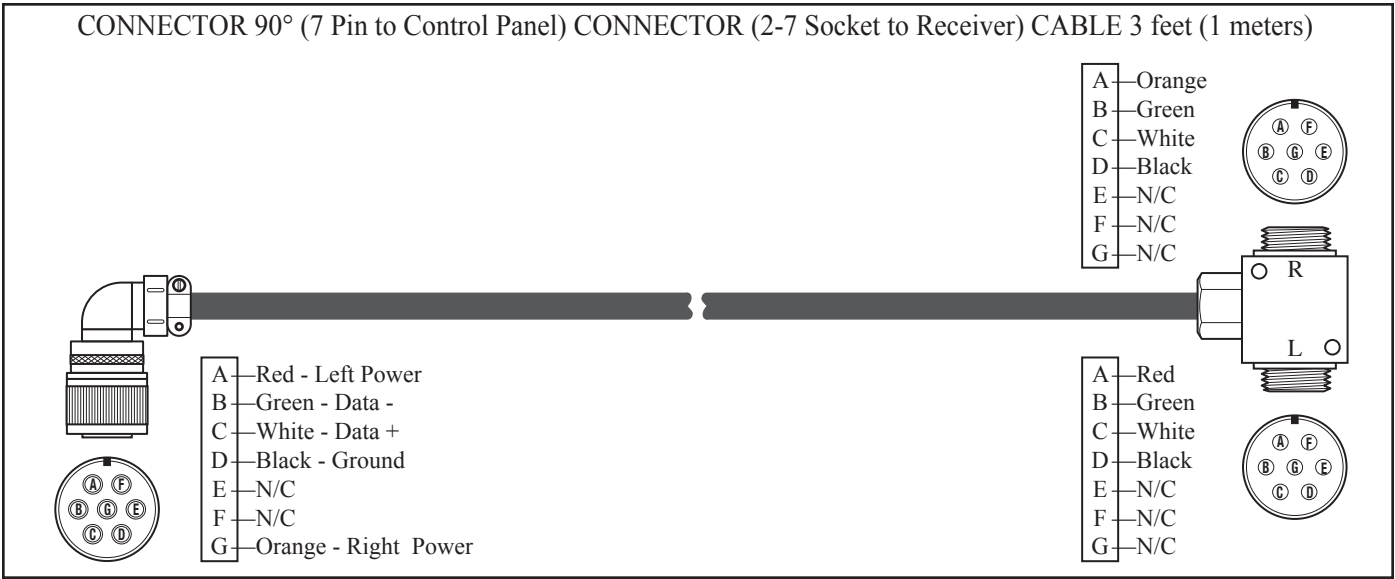

Figure 2-14. Receiver Junction Cable

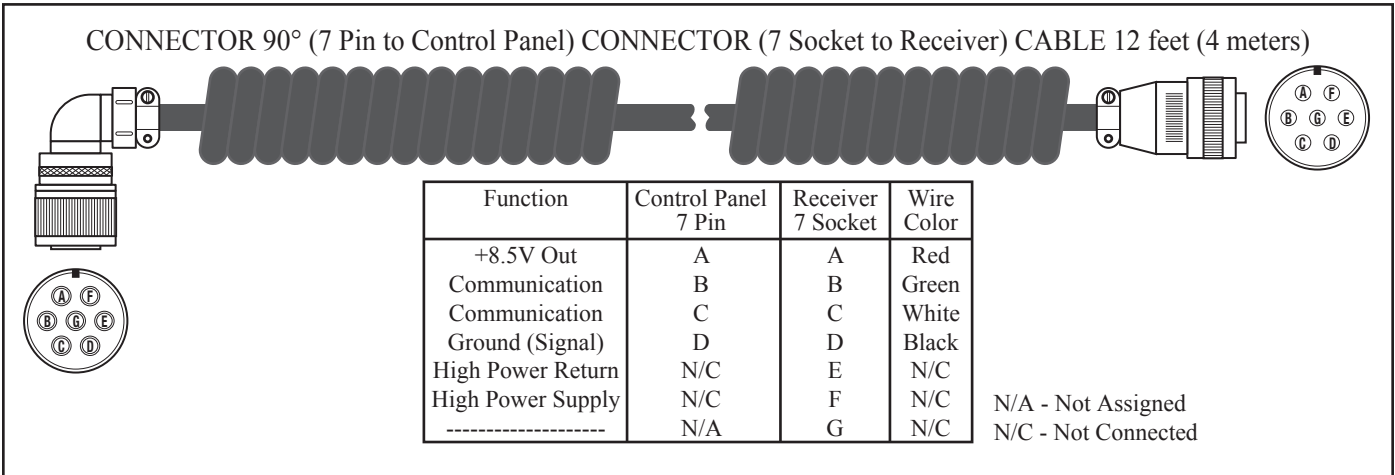

Figure 2-15. Receiver Cable

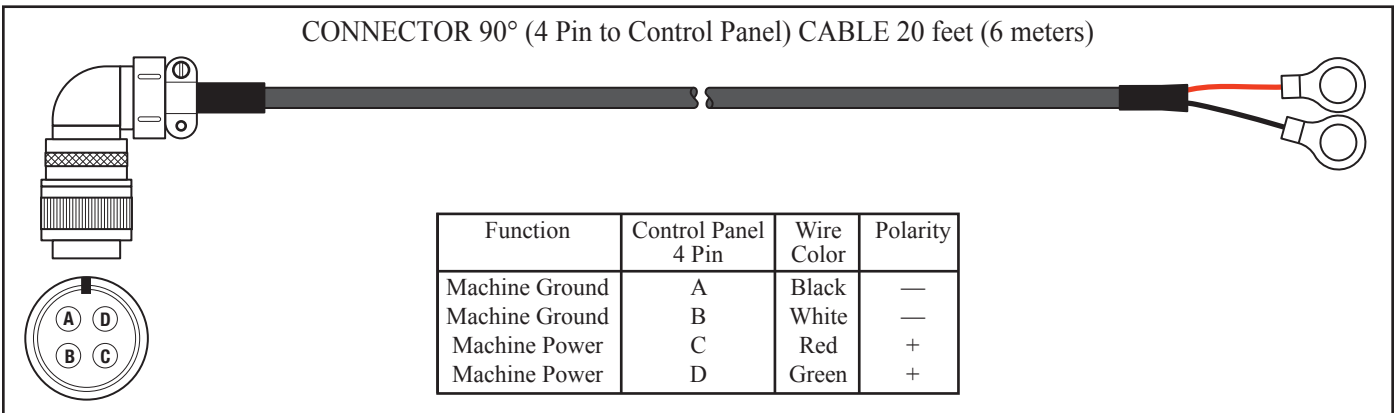

Figure 2-16. Power Cable

(for future use)

TROUBLESHOOTING

SYMPTOM	POTENTIAL CAUSE	REMEDY
Control Panel lamps do not light.	<p>Control Panel not turned on.</p> <p>Power Cable not connected to Control Panel.</p> <p>Power Cable not providing power to the Control Panel.</p> <p>Fuse blown.</p> <p>Electrical short.</p>	<p>Toggle the Power Switch upward (I i).</p> <p>Connect power cable to Control Panel.</p> <p>Check that the Power Cable is connected to the battery. The red wire connects to the positive (+) post and the black wire connects to the negative (-) post.</p> <p>Remove the Power Cable from the Control Panel and use a volt meter to check for 12 volts DC.</p> <p>Check the fuse.</p> <p>Disconnect all cables except the Power Cable. If the lamps still do not cycle when the Control Panel is turned on, contact the local Apache Technologies dealer.</p>
Laser Receiver does not display grade.	<p>No Rotating Laser in range.</p> <p>Laser beam blocked.</p> <p>Laser Receiver not receiving power.</p> <p>Electrical short.</p>	<p>Ensure Laser Receiver is within operating range of Rotating Laser.</p> <p>Ensure beam is striking middle of the Laser Receiver</p> <p>Check and clean glass covering the Laser Receiver's photo cells.</p> <p>Check for obstructions keeping Laser Receiver from seeing the Rotating Laser.</p> <p>Check Fuse in the Control Panel.</p> <p>Check Receiver Cable for damage. Use an Ohm meter to check continuity</p> <p>If LEDs do not cycle when Control Panel is turned On, contact the local Apache Technologies dealer.</p>

Troubleshooting

TROUBLESHOOTING

SYMPTOM	POTENTIAL CAUSE	REMEDY
Laser Grading Box does not raise or lower.	Control Panel not turned on.	Toggle the Power Switch upward (I i).
	No hydraulic flow to Laser Grading Box.	Ensure hydraulic control handle of tractor is in correct position. Ensure auxiliary hydraulics are ON or in continuous flow mode.
	Cables not connected correctly.	Check Solenoid Cable and directional valve for visible damage. Move directional valve spool manually using the overrides on the end of the directional valve.
	Electrical Problems	<div style="border: 1px solid black; background-color: #ff9900; padding: 2px; text-align: center; margin-bottom: 5px;">  WARNING </div> <p>Be sure to stay clear of any moving parts of the Laser Grading Box.</p> <p>If the Laser Grading Box moves, refer to Electrical problems. If the Laser Grading Box does not move, refer to Hydraulic problems.</p>
Hydraulic problems.	Check the Solenoid Cable and directional valve for visible damage. Use an Ohm meter to check cable for continuity. Confirm hydraulic flow through the manifold and returning to the power source through the “T” hose. Contact ATI Group, LLC for help troubleshooting the hydraulic manifold.	
Laser Grading Box moves in opposite direction.	Hydraulic flow reversed.	Confirm the pressure is going in the “P” port. Verify control handle is moving in desired direction.

TROUBLESHOOTING

SYMPTOM	POTENTIAL CAUSE	REMEDY
Laser Grading Box does not seem to cut even across passes.	Control Panel to valve body connections are reversed.	Reverse cable connections so left-side Valve cable is connected to left-side valve body. Repeat for right side.
	Control Panel to Laser Receiver connections are reversed.	Reverse cable connections so left-side Laser Receiver is connected to the L connector on the Junction Block. Repeat for right side.
Box has trouble staying on grade.	Rotating Laser out of range.	Ensure Laser Receiver is within specified operating range of Rotating Laser.
	Laser beam being reflected.	Ensure Rotating Laser's light is not reflecting off other surfaces (windows, windshields, mirrors, etc.) causing multiple readings by the Laser Receiver.
	Multiple laser beams.	Ensure that there are no other lasers operating on the job site or nearby.
	Laser deadband set too narrow.	Ensure the On Grade Deadband is set for rough grading.
	Travel speed is too fast for grade tolerance.	Slow down.
	Hydraulic response too quick.	Decrease the Hydraulic Speed setting.
	Hydraulic flow reversed.	Confirm the pressure is going in the "P" port.

TROUBLESHOOTING

(for future use)

PARTS ILLUSTRATIONS

Serial Number Information.....	4.2
Where To Get Parts and Service	4.2
How To Order Parts	4.2
List of Parts Illustrations.....	4.3

PARTS ILLUSTRATIONS

Serial Number Information

It is very important that the correct serial number is provided when ordering parts. The serial number plate is located on the main frame. Please mark the model and serial number of your Laser Grading Box in the space provided below in case the plate on your Laser Grading Box gets lost or damaged.

Model..... **Serial Number**

Dealer Name **Dealer Phone Number**

Where To Get Parts and Service

When replacement parts and service are required, ATI Group, LLC recommends returning to the dealer from which the product or optional kit was purchased. By going to the dealer, you are dealing with people that understand and know ATI products. Our dealers have the experience servicing these machines and stock the most common parts required to keep your equipment in top working condition.

How To Order Parts

Parts lists contained in this book have been prepared to help you when ordering spare and/or replacement parts. Your order will be filled promptly and accurately when the following information is provided:

1. Model and serial number of the unit. (This specifically identifies the equipment you have and permits us to verify the part numbers in your order.)
2. The parts list page number and catalog number. Include catalog revision number, if applicable.
3. The **Item** number for each part. **Item** numbers on the parts list page correspond with the numbers shown on the illustration.
4. **Part Number** as it appears in the parts list. In most cases this will be a nine-digit number; for example: 315-005-000.
5. The **Description** for the part as it appears on the parts list page.

When a complete assembly is needed, use the assembly number given in the parts list. If no assembly number is given, order by main assembly title and list only the item numbers you want. For example: "Wheel Frame Assembly per 315-509-000, Items 2 through 8, inclusive".

The part ordered may have a new part number, or the part may have been replaced by a newer design with a different part number. In these cases your acknowledgement, shipping papers and invoices will be written listing the current part number first; the old part number you referred to will follow the part description.

Our purpose in doing this is to tell you that the parts are fully interchangeable. This will avoid any unnecessary correspondence or delay in processing your order. We suggest that you add any new number to your parts lists for future use.

NOTE: ATI Group, LLC reserves the right to discontinue models at any time, change specifications, and improve design without notice and without incurring obligation on goods previously purchased and to discontinue supplying any part listed, when the demand does not warrant production.

LIST OF PARTS ILLUSTRATIONS

Figure 4-1.	Main Frame and Cutting Edges	4.4
Figure 4-2.	Wheel Frame and Related Parts.....	4.6
Figure 4-3.	Caster Fork and Single Wheel - Models TD60, TD72, TD84 & TD96.....	4.8
Figure 4-4.	Caster Fork and Dual Wheels - Models TD96 & TD108	4.10
Figure 4-5.	Hydraulic Valve Assembly, Cylinder Assembly and Related Parts	4.12
Figure 4-6.	Hydraulic Valve Assembly.....	4.14
Figure 4-7.	Laser Controls and Related Parts - Apache CB52/Spectra CB30.....	4.16
Figure 4-8.	Control Panel, Laser Receiver 360°, Cables - Apache/Spectra	4.18
Figure 4-9.	Drawbar Kit, with Wheel Locks (Optional).....	4.20
Figure 4-10.	Decals.....	4.22

PARTS ILLUSTRATIONS

Figure 4-1. Main Frame and Cutting Edges

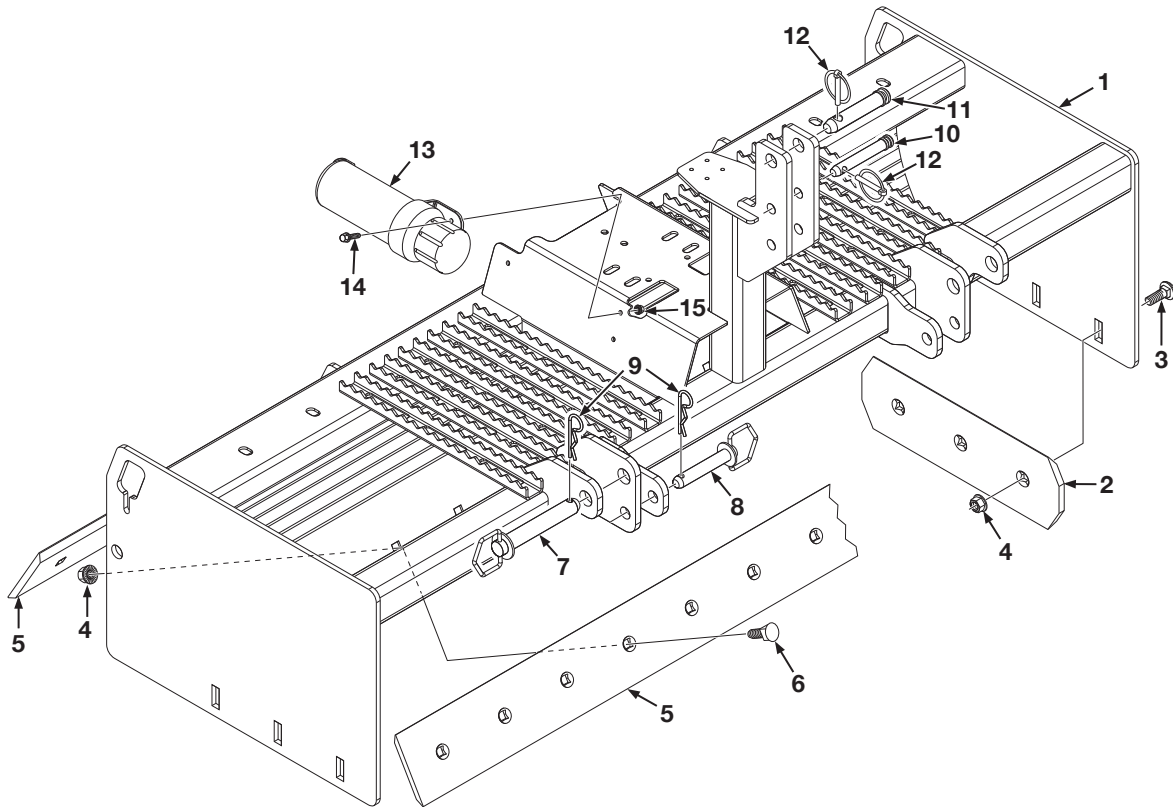

PARTS ILLUSTRATIONS

Figure 4-1. Main Frame and Cutting Edges

Item	Part No.	Qty	Description
1	315-147-100	1	Frame, Main, Tractor, 60"
	315-117-100	1	Frame, Main, Tractor, 72"
	315-118-100	1	Frame, Main, Tractor, 84"
	315-119-100	1	Frame, Main, Tractor, 96"
	315-120-100	1	Frame, Main, Tractor, 108"
2	000-190-072	2	Edge, Cutting, End, DBF, 19-1/2" Long
3	000-150-256	6	Bolt, Carriage, 5/8"-11UNC x 1-1/2" Long
4	000-158-142	AR	Nut, Serrated Flange, 5/8"-11UNC
5	000-190-128	1	Edge, Cutting, DBF, 60" Long
	000-190-075	1	Edge, Cutting, DBF, 72" Long
	000-190-077	1	Edge, Cutting, DBF, 84" Long
	000-190-079	1	Edge, Cutting, DBF, 96" Long
	000-190-091	1	Edge, Cutting, DBF, 108" Long
6	000-150-258	AR	Bolt, Plow, 5/8"-11UNC x 1-3/4" Long
7	000-161-075	2	Pin, Hitch, 1-1/8" Dia. x 7" Long, Category II
8	000-161-076	2	Pin, Hitch, 7/8" Dia. x 5-1/4" Long, Category I
9	000-161-019	4	Pin, Hair, Cotter, 3/16" Dia. x 3-3/4" Long
10	000-161-081	1	Pin, Top Link, 3/4" Dia. x 5-1/2" Long, Category I
11	000-161-085	1	Pin, Top Link, 1" Dia. x 5-1/4" Long, Category II
12	000-161-028	2	Pin, Lynch, Locking, 7/16"
13	001-001-083	1	Canister, Operators Manual
14	000-150-078	3	Bolt, Serrated Flange, 5/16"-18UNC x 1" Long
15	000-158-064	3	Nut, Serrated Flange, 5/16"-18UNC

AR - As Required NSS - Not Serviced Separately ASN - After Serial No. BSN - Before Serial No. LP - Local Purchase

PARTS ILLUSTRATIONS

Figure 4-2. Wheel Frame and Related Parts

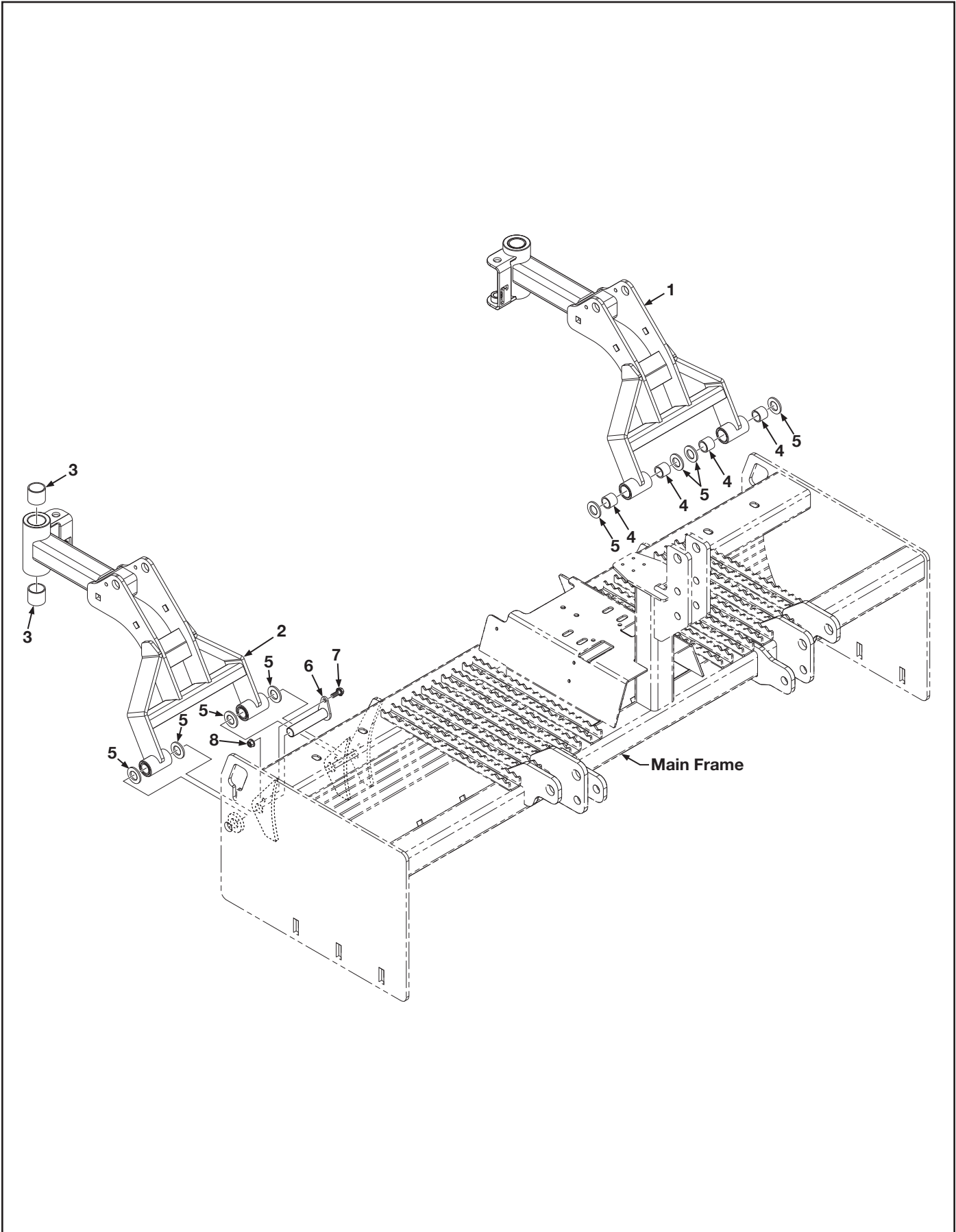

PARTS ILLUSTRATIONS

Figure 4-2. Wheel Frame and Related Parts

Item	Part No.	Qty	Description
1	315-121-200	1	Frame, Wheel, Left, Includes Items 3 & 4
2	315-121-300	1	Frame, Wheel, Right, Includes Items 3 & 4
3	000-176-171	2	Bushing, Wheel Frame, 1-3/4" OD x 1-1/2" ID x 1-1/2" Long
4	000-176-174	4	Bushing, Wheel Frame, 1-1/4" OD x 1" ID x 1" Long
5	000-155-003	8	Bushing, Washer, 1-1/2" OD x 1" ID x 14 Gauge
6	000-161-164	4	Pin, Pivot, Tabbed, 1" Dia. x 5" Long
7	000-150-078	3	Bolt, Serrated Flange, 5/16"-18UNC x 1" Long
8	000-158-064	3	Nut, Serrated Flange, 5/16"-18UNC

AR - As Required NSS - Not Serviced Separately ASN - After Serial No. BSN - Before Serial No. LP - Local Purchase

PARTS ILLUSTRATIONS

Figure 4-3. Caster Fork and Single Wheel - Models TD60, TD72, TD84 & TD96

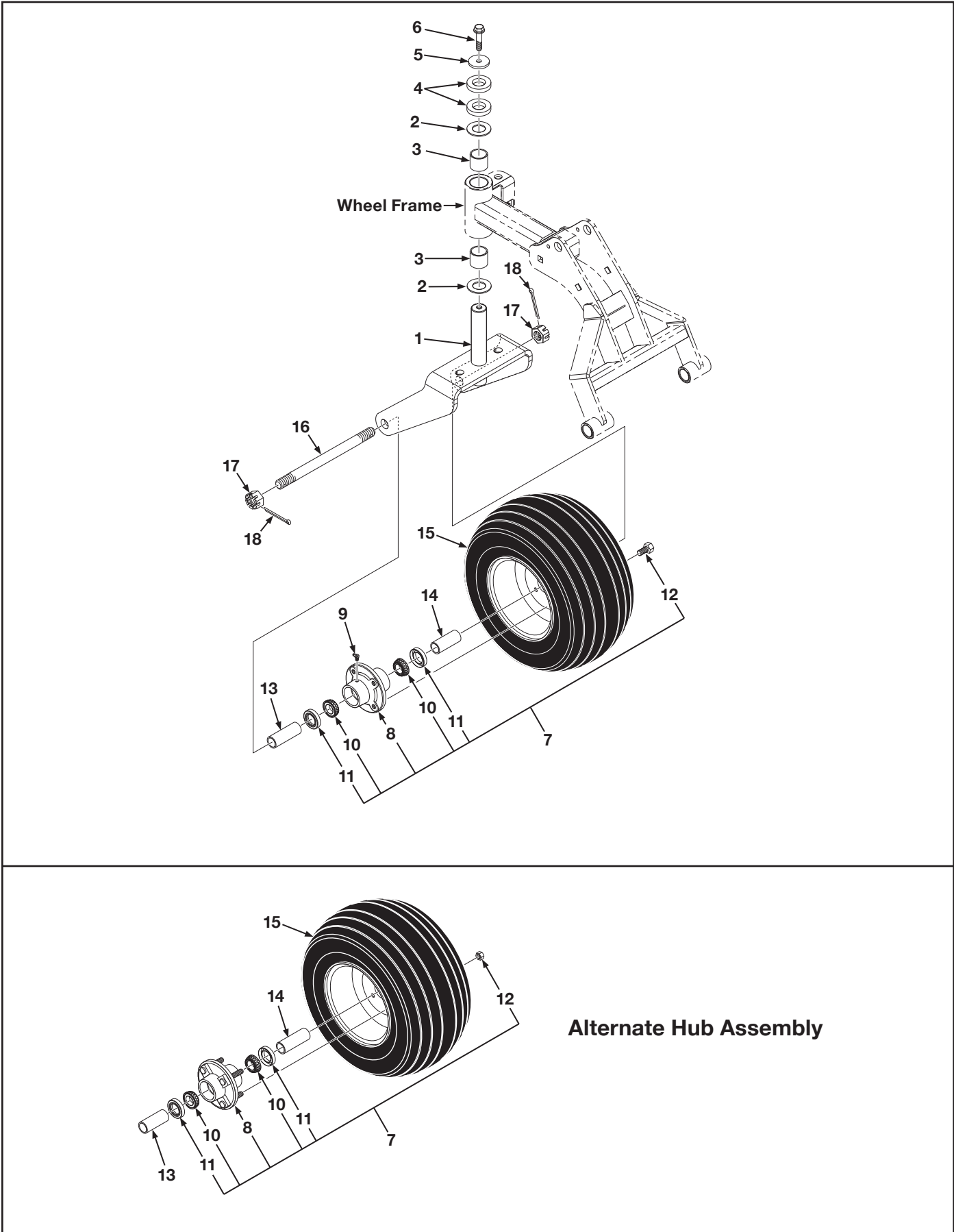

PARTS ILLUSTRATIONS

Figure 4-3. Caster Fork and Single Wheel - Models TD60, TD72, TD84 & TD96

Item	Part No.	Qty	Description
1	315-548-010	2	Fork, Caster
2	000-155-013	2	Bushing, Washer, 2-3/4" OD x 1-1/2" ID x 10 Gauge
3	000-176-171	8	Bushing, Wheel Frame, 1-3/4" OD x 1-1/2" ID x 1-1/2" Long
4	000-176-055	4	Bushing, Wheel Frame, 1-3/4" OD x 1-1/2" ID x 1-1/2" Long
5	000-155-004	4	Washer, Flat, 2-3/4" OD x 17/32" ID x 1/4" Thick
6	000-150-375	4	Bolt, Serrated Flange, 1/2"-13UNC x 1-1/4" Long
7	001-001-069	2	Hub Assembly, Includes Items 8 thru 12
		2	Hub Assembly, Includes Items 8 thru 12 (Alternate Hub Assembly)
8	001-001-074	1	Hub, Wheel, With Outer Race, Includes Item 9
9	NSS	1	Fitting, Grease, 65°
10	000-176-184	2	Bearing, Roller, Tapered, 1" Dia. Bore
11	000-166-457	2	Seal, 1.983" OD x 1.219" ID x .475" Thick
12	000-150-218	4	Bolt, Lug, 1/2"-20UNF x 1-1/4" Long
	000-158-120	4	Nut, Lug, Hex, 1/2"-20UNF (Alternate Hub Assembly)
13	315-598-000	2	Spacer, Wheel Hub, 1-1/4" OD x 3-5/8" Long
14	315-597-000	2	Spacer, Wheel Hub, 1-1/4" OD x 2-7/8" Long
15	001-001-057	2	Wheel/Tire, Foam-Filled, 18.5/8.50-8
16	000-150-359	2	Shaft, Axle, Bolt, Hex Head, 1"-14UNF x 12" Long
17	000-158-193	2	Nut, Castle, Jam, 1"-14UNF
18	000-161-078	2	Pin, Cotter, 1/8" Dia. x 2" Long

AR - As Required NSS - Not Serviced Separately ASN - After Serial No. BSN - Before Serial No. LP - Local Purchase

PARTS ILLUSTRATIONS

Figure 4-4. Caster Fork and Dual Wheels - Models TD96 & TD108

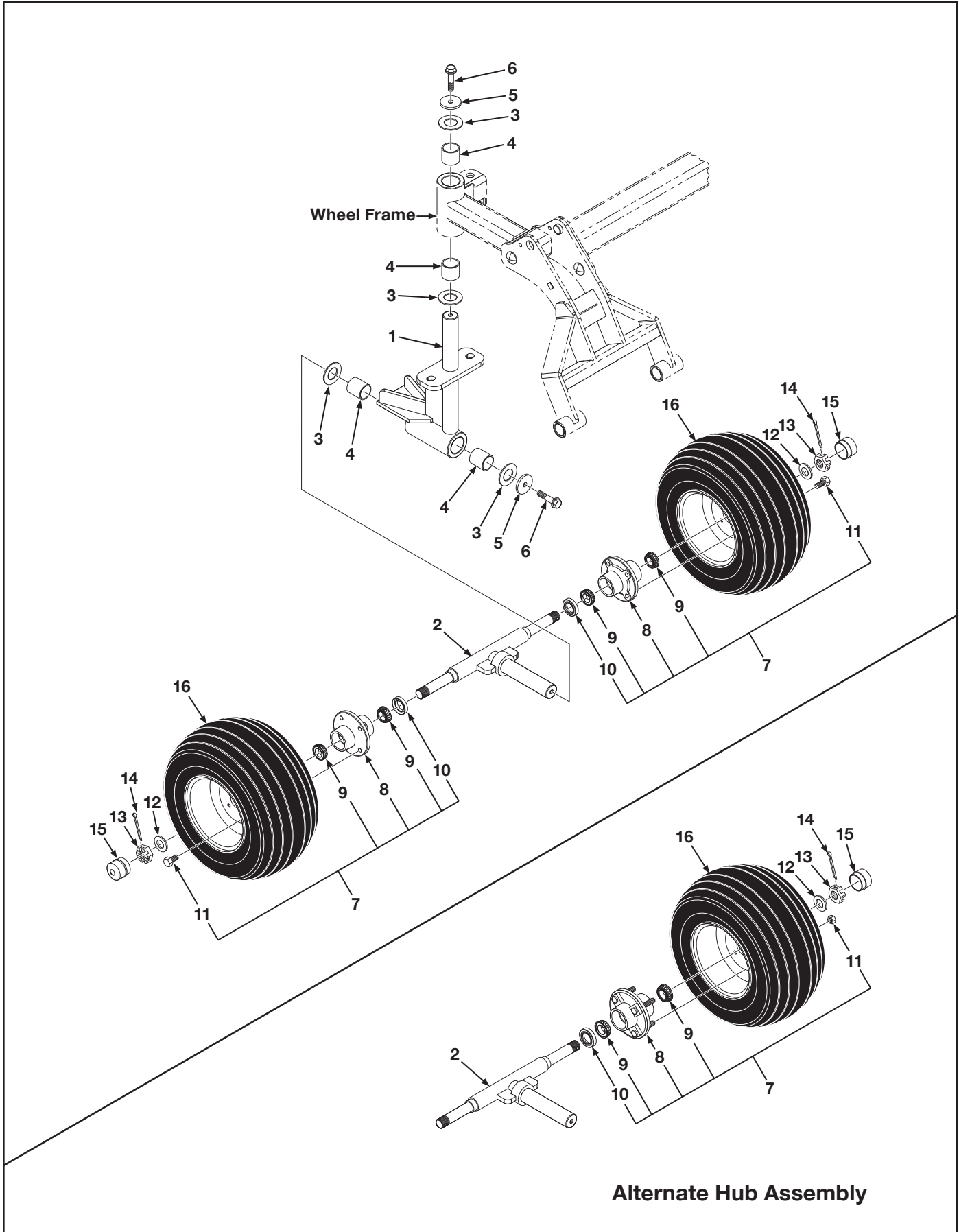

PARTS ILLUSTRATIONS

Figure 4-4. Caster Fork and Dual Wheels - Models TD96 & TD108

Item	Part No.	Qty	Description
1	315-065-310	2	Fork, Caster
2	315-065-400	2	Axle, Dual
3	000-155-013	2	Bushing, Washer, 2-3/4" OD x 1-1/2" ID x 10 Gauge
4	000-176-171	8	Bushing, Wheel Frame, 1-3/4" OD x 1-1/2" ID x 1-1/2" Long
5	000-155-004	4	Washer, Flat, 2-3/4" OD x 17/32" ID x 1/4" Thick
6	000-150-375	4	Bolt, Serrated Flange, 1/2"-13UNC x 1-1/4" Long
7	001-001-069	4	Hub Assembly, Includes Items 8 thru 11
		4	Hub Assembly, Includes Items 8 thru 11 (Alternate Hub Assembly)
8	001-001-074	1	Hub, Wheel, With Outer Race
9	000-176-184	2	Bearing, Roller, Tapered, 1" Dia. Bore
10	000-166-457	2	Seal, 1.983" OD x 1.219" ID x .475" Thick
11	000-150-218	4	Bolt, Lug, 1/2"-20UNF x 1-1/4" Long
	000-158-120	4	Nut, Lug, Hex, 1/2"-20UNF (Alternate Hub Assembly)
12	000-155-003	4	Washer, Flat, 1-1/2" OD x 1" ID x 14 Gauge
13	000-158-193	4	Nut, Castle, 1"-14UNF
14	000-161-078	4	Pin, Cotter, 1/8" Dia. x 2" Long
15	001-001-084	4	Cap, Dust
16	001-001-057	4	Wheel/Tire, Foam-Filled, 18.5/8.50-8

AR - As Required NSS - Not Serviced Separately ASN - After Serial No. BSN - Before Serial No. LP - Local Purchase

PARTS ILLUSTRATIONS

Figure 4-5. Hydraulic Valve Assembly, Cylinder Assembly and Related Parts

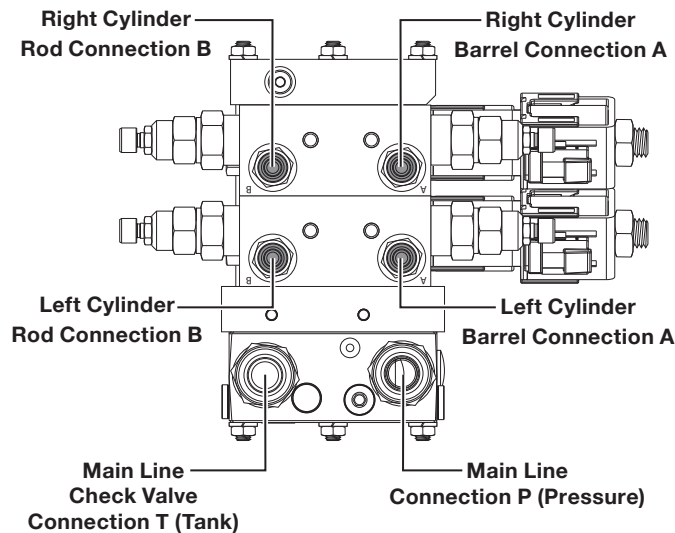
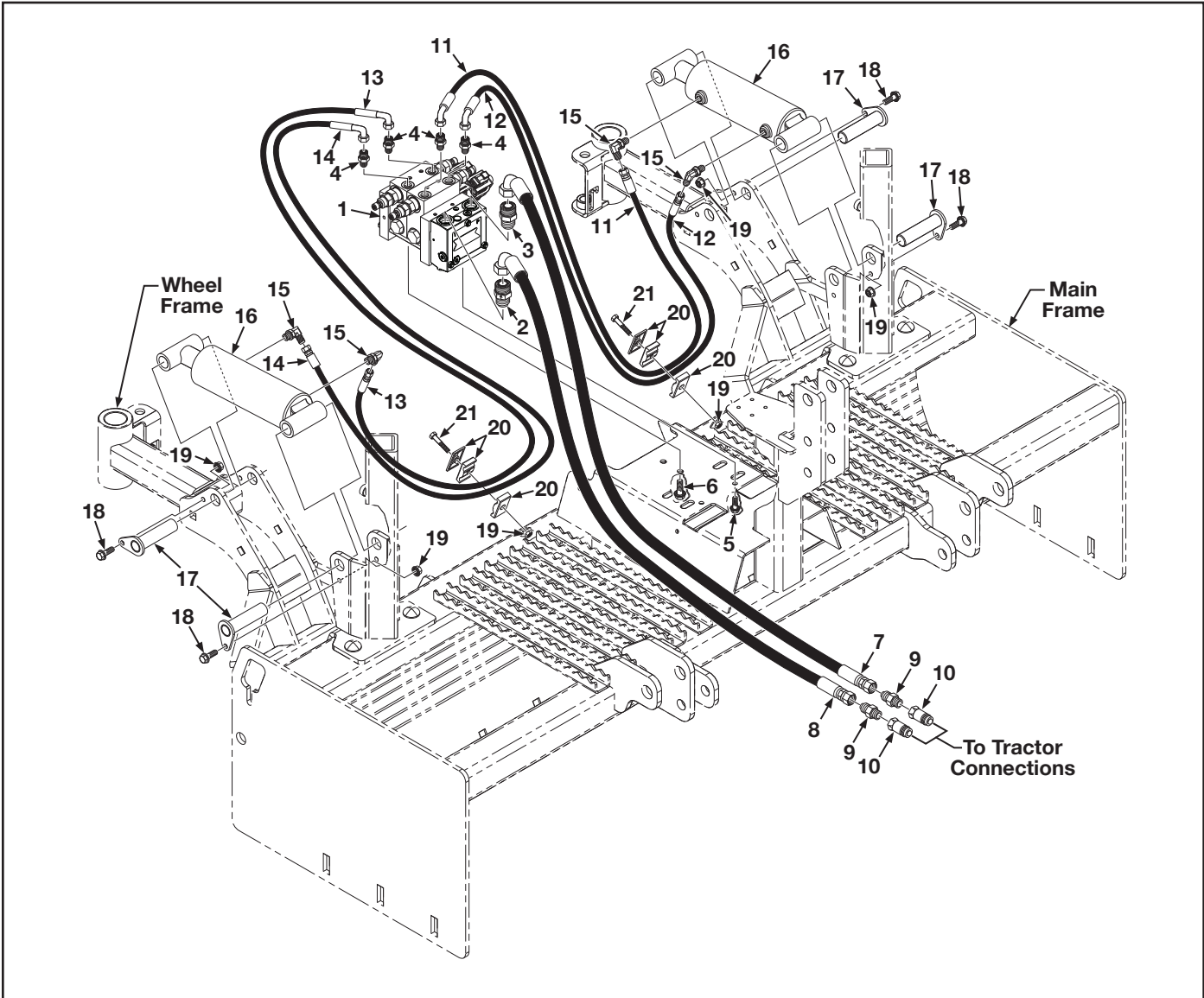

Top View Hydraulic Valve

PARTS ILLUSTRATIONS

Figure 4-5. Hydraulic Valve Assembly, Cylinder Assembly and Related Parts

Item	Part No.	Qty	Description
1	000-166-875	1	Valve Assembly, Hydraulic MVB10, Includes Items 2 & 3, See Breakdown Figure 4-6
2	000-166-824	1	Valve, Check, 12OFS x 12MB, (DO NOT REMOVE FROM ITEM 1)
3	000-166-694	1	Fitting, Adapter, 12OFS x 12MB
4	000-166-685	4	Fitting, Adapter, 6OFS x 6MB
5	000-150-074	2	Bolt, Serrated Flange, 5/16"-18UNC x 3/4" Long
6	000-150-119	1	Bolt, Serrated Flange, 3/8"-16UNC x 3/4" Long
7	000-166-810	1	Hose, 5/8" Dia x 80" L x 10MORB x 12FFORX90, 4,060 PSI
8	000-166-810	1	Hose, 5/8" Dia x 80" L x 10MORB x 12FFORX90, 4,060 PSI
9	000-166-884	2	Adapter, Straight, 10FB x 8MP,
10	000-166-210	2	Coupler, Quick Disconnect, Ag, Male, 1/2"
11	000-166-768	1	Hose, 3/8" Dia x 40" Long x 6FFX x 6FFX90, 3,000 PSI, Model TD60 & TD72
	000-166-765	1	Hose, 3/8" Dia x 48" Long x 6FFORX x 6FFORX90, 3,000 PSI, Models TD84 & TD96
	000-166-779	1	Hose, 3/8" Dia x 60" Long x 6FFX x 6FFX90, 3,000 PSI, Model TD108
12	000-166-897	1	Hose, 3/8" Dia x 38" Long x 6FFORX x 6FFORX90, 3,000 PSI, Model TD72
	000-166-885	1	Hose, 3/8" Dia x 46" Long x 6FFORX x 6FFORX90, 3,000 PSI, Models TD84 & TD96
	000-166-898	1	Hose, 3/8" Dia x 58" Long x 6FFX x 6FFX90, 3,000 PSI, Model TD108
13	000-166-768	1	Hose, 3/8" Dia x 40" Long x 6FFX x 6FFX90, 3,000 PSI, Model TD60 & TD72
	000-166-765	1	Hose, 3/8" Dia x 48" Long x 6FFORX x 6FFORX90, 3,000 PSI, Models TD84 & TD96
	000-166-779	1	Hose, 3/8" Dia x 60" Long x 6FFX x 6FFX90, 3,000 PSI, Model TD108
14	000-166-768	1	Hose, 3/8" Dia x 40" Long x 6FFX x 6FFX90, 3,000 PSI, Model TD72
	000-166-765	1	Hose, 3/8" Dia x 48" Long x 6FFORX x 6FFORX90, 3,000 PSI, Models TD84 & TD96
	000-166-779	1	Hose, 3/8" Dia x 60" Long x 6FFX x 6FFX90, 3,000 PSI, Model TD108
15	000-166-697	4	Elbow, 90°, 6OFS x 6MB
16	000-166-689	2	Cylinder, Hydraulic, 3" Bore x 6" Stroke
17	000-161-164	4	Pin, Pivot, Tabbed, 1" Dia. x 5" Long
18	000-150-078	4	Bolt, Serrated Flange, 5/16"-18UNC x 1" Long
19	000-158-223	4	Nut, Lock, Flange, Nylon-Insert, 5/16"-18UNC
20	000-166-739	2	Clamp Assembly, Hoses
21	000-150-092	2	Bolt, Hex Head, 5/16"-18UNC x 2" Long
			BH-Bulkhead MP-Male Pipe FP-Female Pipe FPX-Female Pipe Swivel FFX- Female O-Ring Flat Face Swivel MB-Male O-Ring Boss FB-Female O-Ring Boss MJ-Male JIC FJ-Female JIC FJX-Female JIC Swivel OFS-O-Ring Face Seal OFSBH-O-Ring Face Seal Bulkhead

AR - As Required NSS - Not Serviced Separately ASN - After Serial No. BSN - Before Serial No. LP - Local Purchase

PARTS ILLUSTRATIONS

Figure 4-6. Hydraulic Valve Assembly

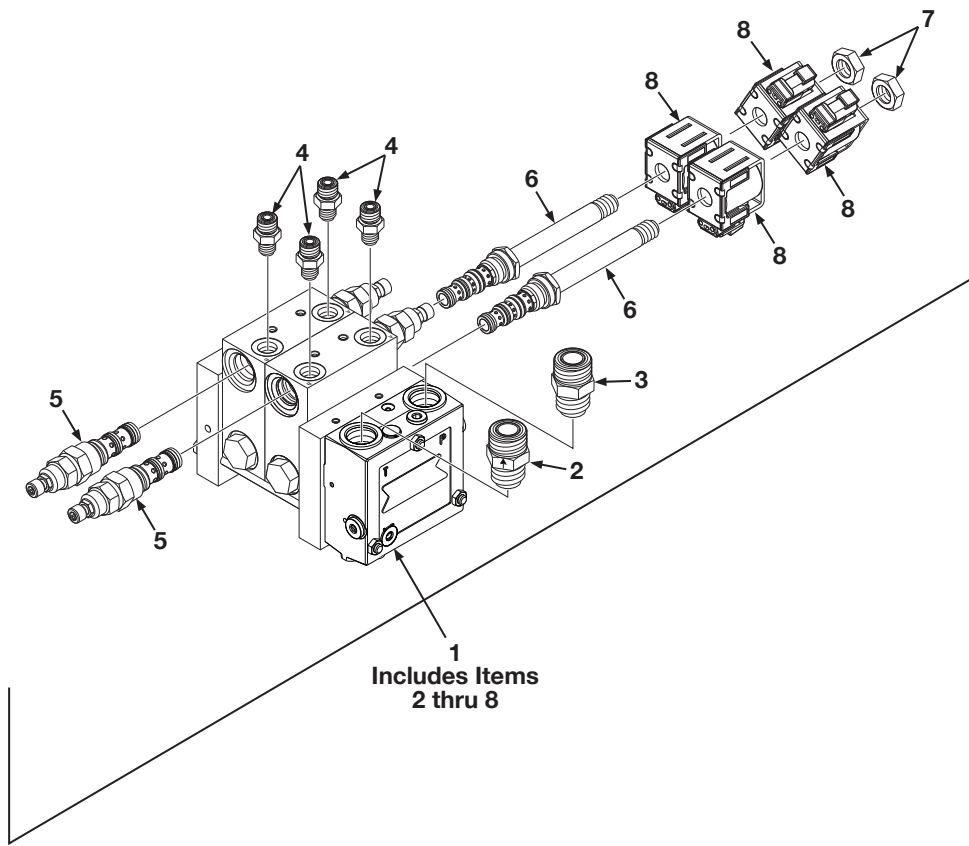

PARTS ILLUSTRATIONS

Figure 4-6. Hydraulic Valve Assembly

Item	Part No.	Qty	Description
1	000-166-875	1	Valve Assembly, Hydraulic MVB10, Includes Items 2 thru 8
2	000-166-824	1	Valve, Check, 12OFS x 12MB, (DO NOT REMOVE FROM ITEM 1)
3	000-166-694	1	Fitting, Adapter, 12OFS x 12MB
4	000-166-685	4	Fitting, Adapter, 6OFS x 6MB
5	000-166-844	4	Valve, Counter Balance
6	NSS	2	Stem, Includes Item 7
7	NSS	2	Nut
8	000-166-843	4	Coil

AR - As Required NSS - Not Serviced Separately ASN - After Serial No. BSN - Before Serial No. LP - Local Purchase

PARTS ILLUSTRATIONS

Figure 4-7. Laser Controls and Related Parts - Apache CB52/Spectra CB30

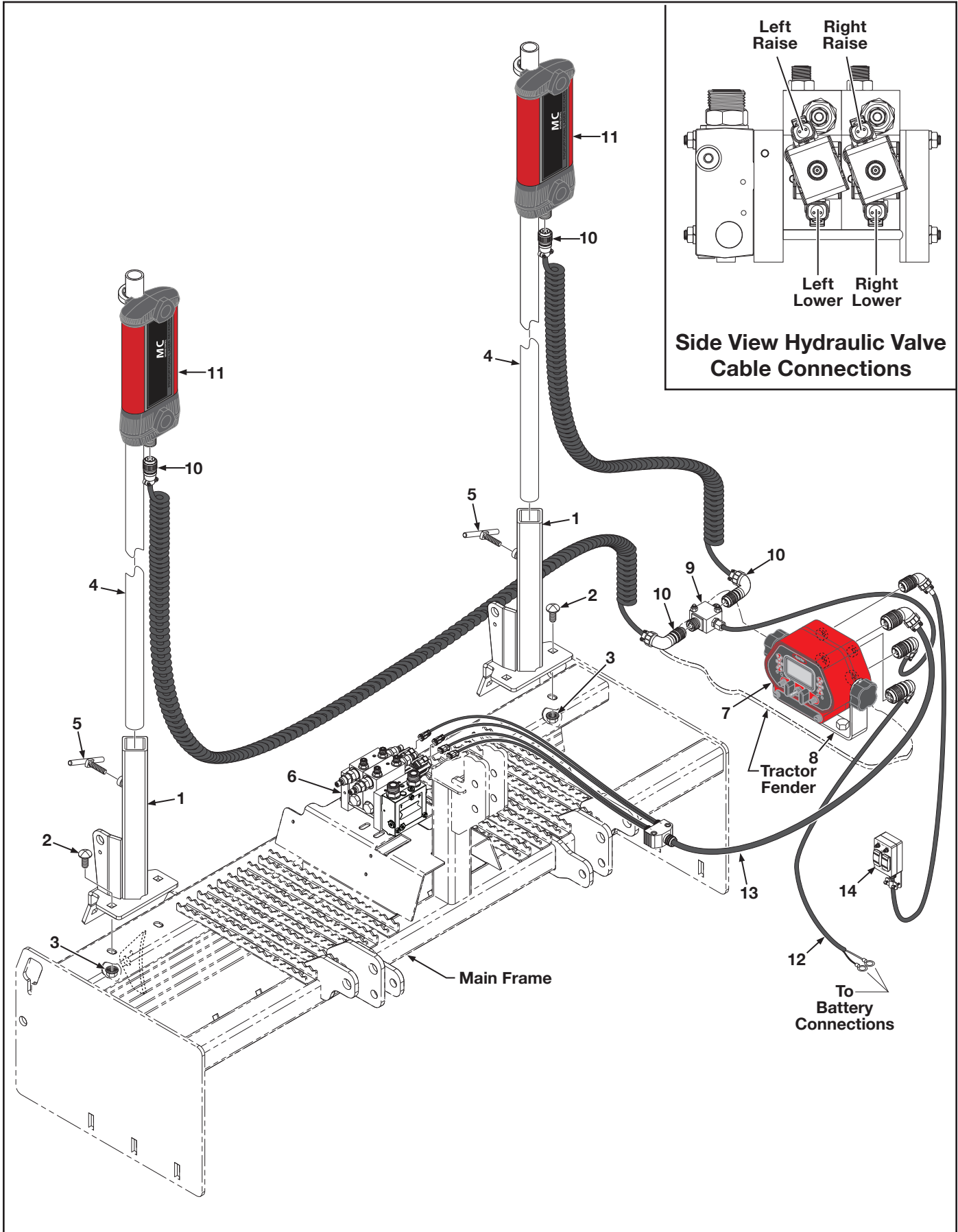

PARTS ILLUSTRATIONS

Figure 4-7. Laser Controls and Related Parts - Apache CB52/Spectra CB30

Item	Part No.	Qty	Description
1	315-117-700	2	Mount, Mast
2	000-150-256	8	Bolt, Carriage, 5/8"-11UNC x 1-1/2" Long
3	000-158-142	8	Nut, Serrated, 5/8"-11UNC
4	001-001-052	2	Pole, Mast, 1-1/2" Dia x 7' Long
5	001-001-053	2	Handle, Tee
6	000-166-875	1	Valve Assembly, Hydraulic MVB10, See Breakdown Figure 4-6
7	000-200-176	1	Panel, Control, Apache CB52, Red, See Breakdown Figure 4-8
	000-200-213	1	Panel, Control, Spectra CB30, Yellow, See Breakdown Figure 4-8
8	001-001-075	1	Bracket, Control Panel
9	000-200-281	1	Cable, Dual Junction Block, Junction, 10' Long
10	000-200-187	2	Cable, Receiver, Coiled, 16' Long
11	000-200-093	2	Receiver, Laser 360°, Apache B5MC Red
	000-200-275	2	Receiver, Laser 360°, Spectra B5MC Yellow
12	000-200-097	1	Cable, Power, 4-Wire, 20' Long
13	000-200-329	1	Cable, Solenoid, Dual, 90° Connector, 16' Long
14	000-200-255	1	Switch Assembly, Remote, Auto/Manual, Raise/Lower, 10' Long

AR - As Required NSS - Not Serviced Separately ASN - After Serial No. BSN - Before Serial No. LP - Local Purchase

PARTS ILLUSTRATIONS

Figure 4-8. Control Panel, Laser Receiver 360°, Cables - Apache/Spectra

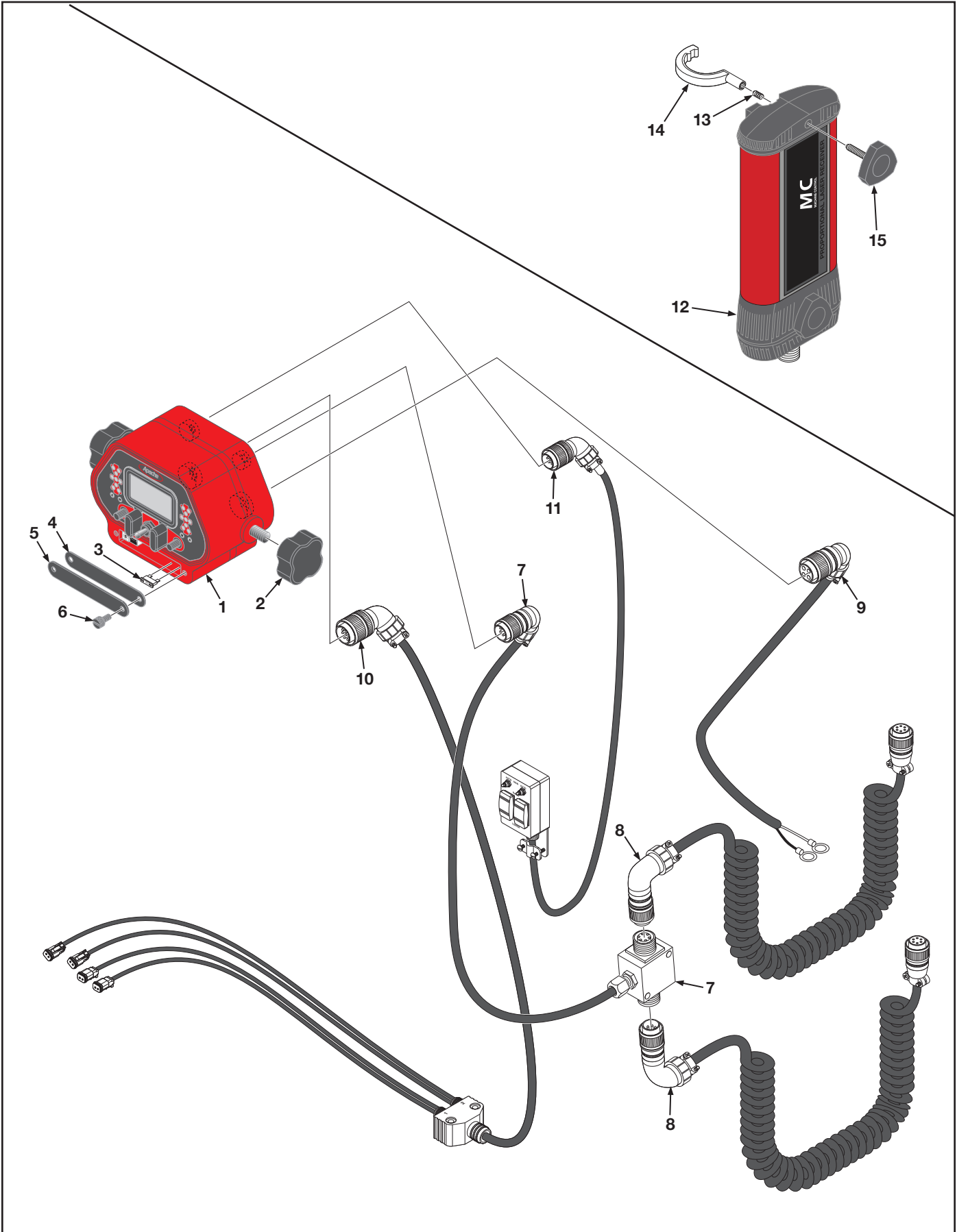

PARTS ILLUSTRATIONS

Figure 4-8. Control Panel, Laser Receiver 360°, Cables - Apache/Spectra

Item	Part No.	Qty	Description
1	000-200-176	1	Panel, Control, Apache CB52, Red, Includes Items 2 thru 6
	000-200-213	1	Panel, Control, Spectra CB30, Yellow, Includes Items 2 thru 6
2	000-200-112	2	Knob
3	LP	1	Fuse, 25 Amp
4	000-200-115	1	Gasket, Front Cover Plate
5	000-200-114	1	Plate, Front Cover
6	000-200-113	2	Screw, Thumb
7	000-200-281	1	Cable, Dual Junction Block, Junction, 10' Long
8	000-200-187	2	Cable, Receiver, Coiled, 16' Long
9	000-200-097	1	Cable, Power, 4-Wire, 20' Long
10	000-200-329	1	Cable, Solenoid, Dual, 90° Connector, 16' Long
11	000-200-255	1	Switch Assembly, Remote, Auto/Manual, Raise/Lower, 10' Long
12	000-200-093	1	Receiver, Laser 360°, Apache B5MC Red, Includes Items 11 thru 13
	000-200-275	1	Receiver, Laser 360°, Spectra B5MC Yellow, Includes Items 11 thru 13
13	000-161-094	2	Spring, Clamp, Compression
14	000-200-108	2	Clamp, Universal, 2" Dia.
15	000-200-107	2	Knob, Clamp

AR - As Required NSS - Not Serviced Separately ASN - After Serial No. BSN - Before Serial No. LP - Local Purchase

PARTS ILLUSTRATIONS

Figure 4-9. Drawbar Kit, with Wheel Locks (Optional)

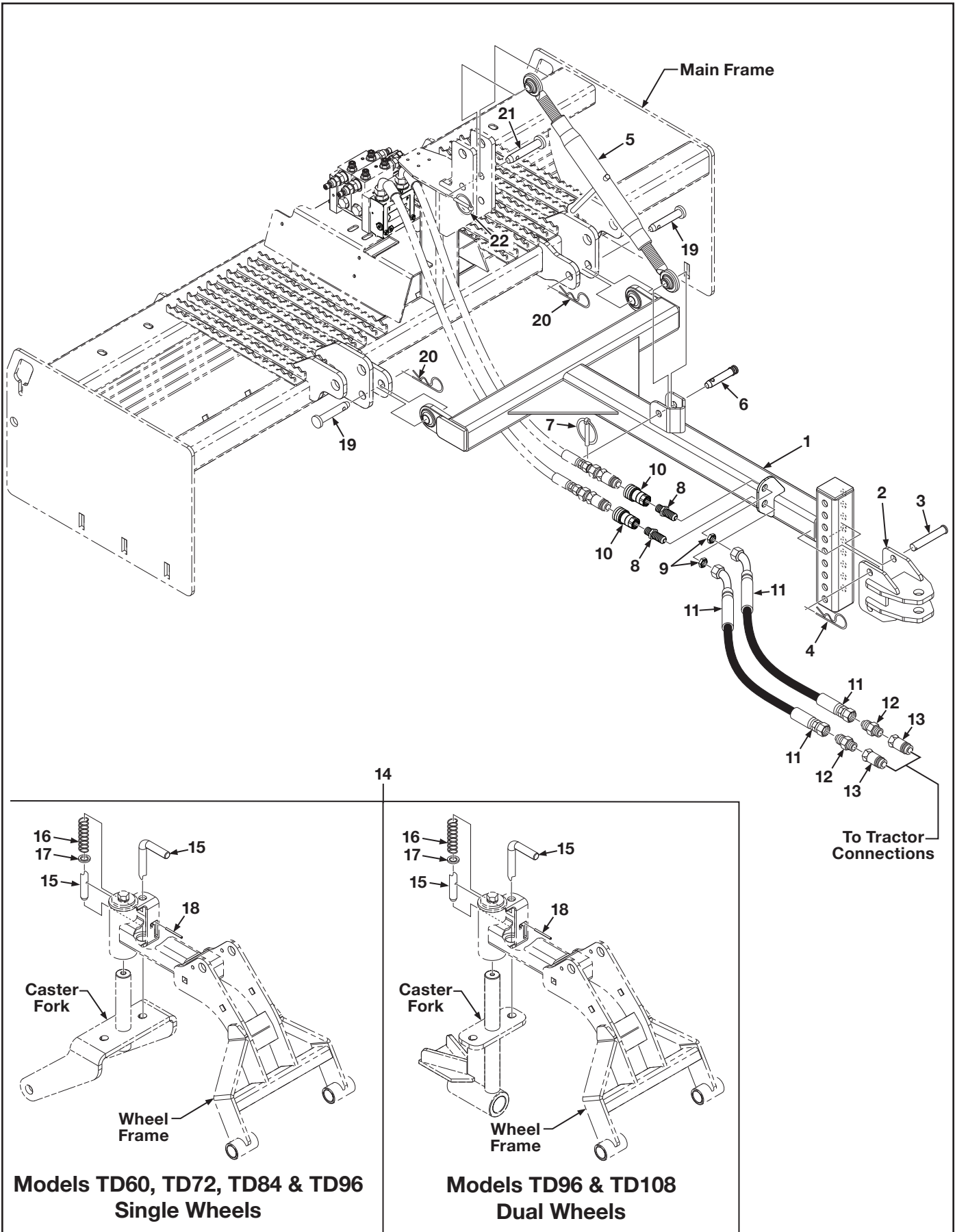

PARTS ILLUSTRATIONS

Figure 4-9. Drawbar Kit, with Wheel Locks (Optional)

Item	Part No.	Qty	Description
	315-547-000	1	Kit, Drawbar, Category I, Includes Items 1 thru 18
1	315-541-000	1	Drawbar, Category I
2	315-542-000	1	Hitch, Clevis
3	000-161-079	2	Pin, Clevis, 3/4" Dia. x 4-1/2" Long
4	000-161-071	2	Pin, Cotter, Hair, .148" Dia. x 2-11/16" Long
5	001-001-064	1	Top Link
6	000-161-080	1	Pin, Top Link, 3/4" Dia. x 4-1/2" Long
7	000-161-028	1	Pin, Lynch, Locking, 7/16"
8	000-166-447	2	Connector, Bulkhead, 8MP x 8BH, Includes Item 9
9	NSS	2	Nut, Hex, Jam Lock
10	000-166-218	2	Coupler, Quick Disconnect, Ag, Female, 1/2" x 1/2" NPT
11	000-166-616	2	Hose, 1/2" Dia. x 58" Long x 8FJX x 8FJX45, 3,000 PSI
12	000-166-168	2	Adapter, Straight, 8MJ x 8MP
13	000-166-210	2	Coupler, Quick Disconnect, Ag, Male, 1/4"
14	315-645-000	2	Kit, Wheel Lock, Caster Lock, Includes Items 15 thru 18
15	000-161-136	1	Pin, Lock, Caster Fork, 3/4" Dia. x 7" Long
16	000-161-133	1	Spring, Compression
17	000-155-096	1	Washer, Flat, 3/4" Narrow
18	000-161-119	1	Pin, Roll, 3/16" Dia. x 2-1/4" Long
19	000-161-076	2	Pin, Hitch, 7/8" Dia. x 5-1/4" Long, Category I
20	000-161-019	2	Pin, Hair, Cotter, 3/16" Dia. x 3-3/4" Long
21	000-161-081	1	Pin, Top Link, 3/4" Dia. x 5-1/2" Long, Category I
22	000-161-028	1	Pin, Lynch, Locking, 7/16"
			BH-Bulkhead MP-Male Pipe FP-Female Pipe FPX-Female Pipe Swivel FFX- Female O-Ring Flat Face Swivel MB-Male O-Ring Boss FB-Female O-Ring Boss MJ-Male JIC FJ-Female JIC FJX-Female JIC Swivel OFS-O-Ring Face Seal OFSBH-O-Ring Face Seal Bulkhead

AR - As Required NSS - Not Serviced Separately ASN - After Serial No. BSN - Before Serial No. LP - Local Purchase

PARTS ILLUSTRATIONS

Figure 4-10. Decals

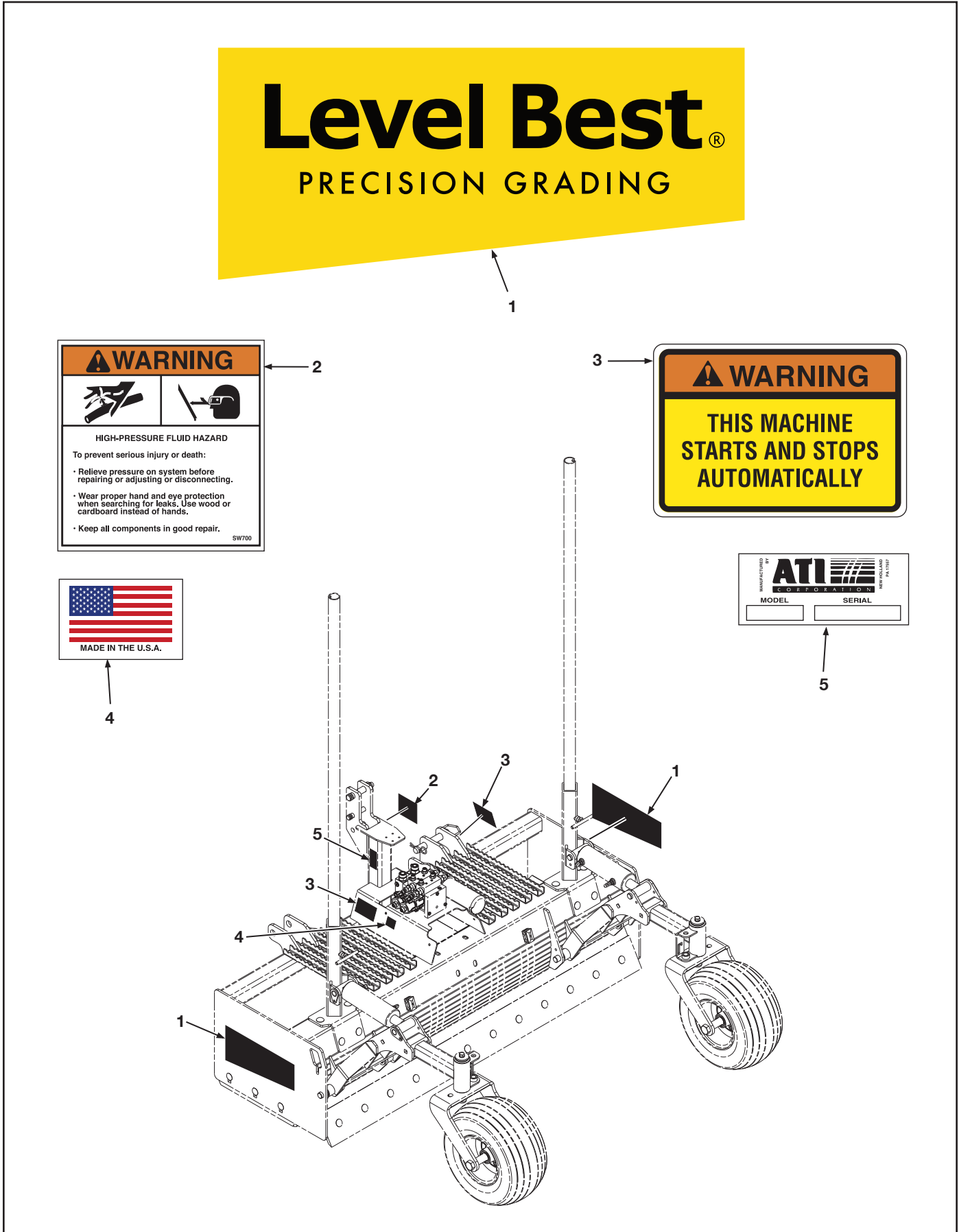

PARTS ILLUSTRATIONS

Figure 4-10. Decals

Item	Part No.	Qty	Description
1	000-186-045	2	Decal, Level Best Logo
2	000-186-041	1	Decal, Warning, High Pressure
3	000-186-094	2	Decal, Warning, This Machine Starts & Stops Automatically
4	000-186-092	1	Decal, Made in U.S.A.
5	000-186-035	1	Plate, Model/Serial, Adhesive Back

AR - As Required NSS - Not Serviced Separately ASN - After Serial No. BSN - Before Serial No. LP - Local Purchase

(for future use)

INDEX

A		P	
Align Rotating Laser with Grade Stakes	1.8	Parts Illustrations	4.1
Apache/Spectra Controls	2.1	Purpose	1.3
B		R	
Benching	1.8	Rotating Laser	1.4
Benching And Operating	1.8		
Benching with a Rod Eye	1.9	S	
C		Safety Information	v
Cables Apache/Spectra	2.13	Safety Precaution Definitions	v
Calibration	1.12	Serial Number Information	4.2
Caster Fork and Dual Wheels - Models TD96 & TD108	4.10	Service	1.12
Caster Fork and Single Wheel - Models TD60, TD72, TD84 & TD96	4.8	Set-Up for Level Grading	1.6
Cleaning	1.11	Set-Up for Sloped Grading	1.6
Components	1.3	Storage and Transport	1.11
Control Panel Apache/Spectra	2.5	Systems Features and Basic Operation	1.1
Control Panel, Laser Receiver 360°, Cables - Apache/Spectra	4.18	T	
D		Table of Contents	iii
Decals	4.22	Troubleshooting	3.1
Disclaimer	i	W	
Drawbar Kit, with Wheel Locks (Optional)	4.20	Warranty	iv
E		Wheel Frame and Related Parts	4.6
Equipment Set-Up	1.4	Where To Get Parts and Service	4.2
G			
Grade Stake with Elevation Mark	1.7		
H			
How To Order Parts	4.2		
Hydraulic Valve Assembly	4.14		
Hydraulic Valve Assembly, Cylinder Assembly and Related Parts	4.12		
I			
Index	5.1		
J			
Job Site Set-Up	1.6		
L			
Laser Controls and Related Parts - Apache CB52/Spectra CB30	4.16		
Laser Receiver Apache/Spectra	2.6, 2.12, 2.13		
M			
Main Frame and Cutting Edges	4.4		
Maintenance	1.11		
O			
Operation Apache/Spectra	2.8		

(for future use)

