

OPERATORS & PARTS MANUAL

SC - SERIES TRACTOR BOX

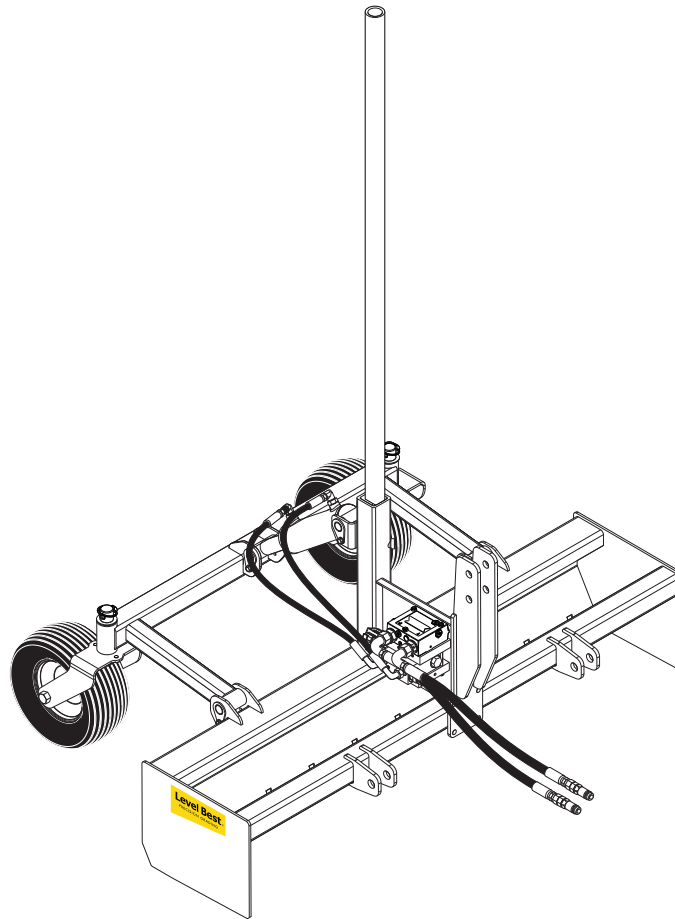

ATI Group, LLC
New Holland, PA 17557
1-800-342-0905
LevelBestGrading.com

COPYRIGHT 2024 by
ATI Group, LLC
250 Earland Drive
New Holland, PA 17557 U.S.A.

DISCLAIMER

THE INFORMATION IN THIS MANUAL IS PROVIDED TO PROMOTE THE SAFE USE OF, AND ASSIST THE OPERATOR IN ACHIEVING THE BEST PERFORMANCE FROM, PARA-LEVEL GRADING BOX DESCRIBED HEREIN, FOR THEIR INTENDED APPLICATIONS.

TABLE OF CONTENTS

Table of Contents	iii
Warranty.....	iv
Safety Information	v
Systems Features and Basic Operation.....	1.1
Troubleshooting	2.1
Parts Illustrations	3.1
Serial Number Information.....	3.2
Where To Get Parts and Service	3.2
How To Order Parts	3.2
List of Parts Illustrations.....	3.3
Index	4.1

WARRANTY

General Provisions. The warranties described below are provided by ATI Group LLC (“ATI”) to the original purchaser of new Level Best grading equipment (“Equipment”) from an authorized Level Best dealer. Under these warranties, ATI will repair or replace, at its option, any covered part which is found to be defective in material or workmanship during the applicable warranty term. Warranty service must be performed by a dealer or service center authorized by ATI to sell and/or service the type of Equipment involved, which will use only new or remanufactured parts or components furnished by ATI. Warranty service will be performed without charge to the purchaser for parts or labor. The purchaser will be responsible, however, for any service call and/or transportation of product to and from the dealer’s or service center’s place of business, for any premium charged for overtime labor requested by the purchaser, and for any service and/or maintenance not directly related to any defect covered under the warranties below.

What Is Warranted. All parts of any new Level Best grading equipment are warranted for 36 months except for the following: (1) wear parts, and (2) third-party machine guidance systems (which are warranted under their respective manufacturer’s warranty). The warranty term for all coverage begins at the time that any person, dealer, or agent first places a unit into service. At the latest, a unit is considered placed into service when delivered to an initial retail purchaser.

What Is Not Warranted. ATI is not responsible for the following:

- (1) Used Equipment;
- (2) Any Equipment that has been altered or modified in ways not approved by ATI;
- (3) Depreciation or damage caused by normal wear, lack of reasonable and proper maintenance, failure to follow operating instructions, misuse, lack of proper protection during storage, or accident;
- (4) Normal maintenance parts and service;
- (5) Economic loss including lost profit, equipment rental, or other expenses.

Securing Warranty Service. To secure warranty service, the purchaser must (1) Report the product defect to an authorized dealer and request repair within the applicable warranty term, (2) Present evidence of the warranty start date, and (3) Make the equipment available to an authorized dealer or service center within a reasonable time.

Limitation Of Implied Warranties and Other Remedies. To the extent permitted by law, neither ATI nor any company affiliated with it makes any warranties, representations or promises as to the quality, performance or freedom from defect of the Level Best Equipment covered by this warranty. IMPLIED WARRANTIES OF MERCHANTABILITY AND FITNESS FOR A PARTICULAR PURPOSE, TO THE EXTENT APPLICABLE, SHALL BE LIMITED IN DURATION TO THE APPLICABLE PERIOD OF WARRANTY SET FORTH ON THIS PAGE. THE PURCHASER’S ONLY REMEDIES IN CONNECTION WITH THE BREACH OR PERFORMANCE OF ANY WARRANTY ON THE LEVEL BEST EQUIPMENT ARE THOSE SET FORTH ON THIS PAGE. IN NO EVENT WILL THE DEALER, ATI, OR ANY COMPANY AFFILIATED WITH ATI, BE LIABLE FOR INCIDENTAL OR CONSEQUENTIAL DAMAGES.

No Dealer Warranty. The selling dealer makes no warranty of its own and the dealer has no authority to make any representation or promise on behalf of ATI, or to modify the terms or limitations of this warranty in any way.

SAFETY INFORMATION

This manual is furnished to you, the owner/operator, as a guide to get the greatest benefit from your Grading Box. ATI Group, LLC wants you to be able to get the most use out of your Grading Box through safe and efficient operation.

Before attempting to operate the Grading Box, carefully read all sections of this manual. Be sure that you thoroughly understand all of the safety information and operating procedures.

SAFETY PRECAUTION DEFINITIONS

Dangers, Warnings, Cautions, and Notes are strategically placed throughout this manual to further emphasize the importance of personal safety, qualifications of operating personnel, and proper use of the grading box in its intended application. These precautions supplement and/or complement the safety information decals affixed to the unit and include headings that are defined as follows:

DANGER

Indicates an imminently hazardous situation which, if not avoided, will result in death or serious injury.

WARNING

Indicates a potentially hazardous situation or practice which, if not avoided, could result in death or serious injury.

CAUTION

Indicates a potentially hazardous situation or practice which, if not avoided, will result in damage to equipment and/or minor injury.

NOTE: Indicates an operating procedure, practice, etc., or portion thereof, which is essential to highlight.

- Always use caution and safe operating practices when operating this equipment.
- Always set the Automatic/Manual Switch on the Control Panel to MANUAL before leaving the operator's seat or whenever the machine is not moving.

- Always allow for clearance under the cutting edge of the machine when tuning the system or when switching to automatic control. Insufficient clearance could cause the machine to lift itself off the ground as its cutting edge attempts to achieve the programmed slope.
- Never adjust the position of the Laser Receiver when the system is in automatic control.
- Never perform service work on your machine or the Automatic Control System when the system is in automatic control.
- Install all safety panels and guards before operating your equipment.
- Stay clear of all moving parts when the machine is in operation.
- Keep all people clear of the machine when it is running.
- Keep feet and other body parts from under the cutting edges of the machine at all times.
- Read and comply with all safety recommendations of your Tractor/Skid Steer manufacturer, as outlined in its operator and service manuals.

NOTE: References made to left, right, front, and rear are those directions viewed from behind the power unit and grading box.

NOTE: Some equipment depicted in illustrations may not reflect exact production model configurations.

NOTE: All safety, operating, and servicing information reflects current production models at the time of publication of this manual.

NOTE: ATI Group, LLC reserves the right to discontinue models at any time, change specifications, and improve design without notice and without incurring obligation on goods previously purchased and to discontinue supplying any part listed, when the demand does not warrant production.

(for future use)

SYSTEMS FEATURES AND BASIC OPERATION

SYSTEMS FEATURES AND BASIC OPERATION	1.1
List of Illustrations.....	1.2
Purpose	1.3
Components	1.3
Rotating Laser.....	1.4
Cables	1.4
Job Site Set-Up	1.5
Set-Up for Level Grading.....	1.5
Set-Up for Sloped Grading.....	1.5
Benching And Operating	1.7
Benching.....	1.7
Benching with a Rod Eye.....	1.8
Operation	1.8
Specifications and Maintenance	1.10
Dimensions.....	1.10
SC Series Hydraulic Valve.....	1.10
Maintenance.....	1.11
Storage and Transport.....	1.11
Cleaning.....	1.11
Cables and Hoses.....	1.11
Machine	1.11
Calibration	1.11
Service	1.11

SYSTEMS FEATURES AND BASIC OPERATION

LIST OF ILLUSTRATIONS

Figure 1-1.	Plane of Laser Light with Components of the Automatic Control System.....	1.3
Figure 1-2.	Rotating Laser	1.4
Figure 1-3.	Method One: Align Rotating Laser with Grade Stakes.....	1.5
Figure 1-4.	Sight over Rotating Laser.....	1.5
Figure 1-5.	Grade Stake with Elevation Mark	1.6
Figure 1-6.	Method Two: Align Rotating Laser with Grade Stakes	1.6
Figure 1-7.	Lube and Maintenance Chart	1.11

SYSTEMS FEATURES AND BASIC OPERATION

PURPOSE

The Level Best Laser Grading Box is a cost-efficient method for fine grading. Various capacities sized to fit your tractor with a choice of Automatic Control Systems are available.

Laser-guided depth control provides unmatched measurement of plane from a single Rotating Laser. Grade information from the Rotating Laser is processed and automatically directs the grading box's hydraulics to maintain the elevation of the cutting edge.

The Laser Grading Box "rides" on gauge wheels at the rear of the frame. Each gauge wheel is attached to a hydraulic cylinder and "floats" independently of the other. By using a separate cylinder with an independent control system for each gauge wheel, the double-cylinder Laser Grading Box is able to provide a more accurate side-to-side grade than boxes with a single cylinder.

Grade Position LEDs on each Laser Receiver indicate the location of the box's cutting edge relative to the required finished grade (the Control Panel has a set of LEDs that mimic the Laser Receiver's LEDs).

- In manual control, the operator watches the Grade Position LEDs and uses the box's controls to keep the center LEDs lit, thereby keeping the box "On Grade".

- In automatic control, the Automatic Control System controls the box's hydraulic cylinders to keep the center LEDs lit, thereby keeping the box "On Grade". Each end of the cutting edge responds separately to the inputs appropriate Automatic Control System installed on that end.

COMPONENTS

The control system consists of 4 components:

Rotating Laser – Provides a reference Plane of Laser Light over the job site (refer to Figure 1-1). The light plane may be level or set at an angle to match the slope of the ground.

Laser Receivers – Mounted at a specific height on a mast on the Laser Grading Box, it determines the difference in depth based on the Plane of Laser Light.

Control Panel – Mounted on the tractor within easy reach of the operator, the Control Panel process data received from their connected Laser Receiver and from the operator. LEDs indicate the location of the box's cutting edge relative to the desired finish grade. If set to Automatic, it provides a signal to the Valve Assembly to either raise or lower the appropriate end of the Laser Grading Box.

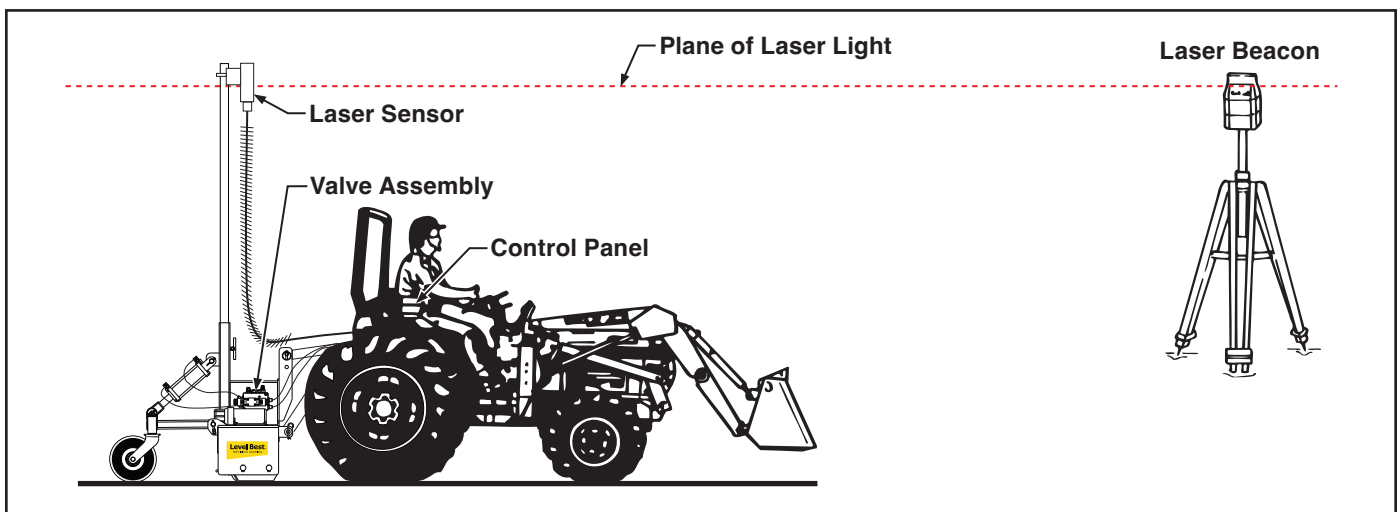

Figure 1-1. Plane of Laser Light with Components of the Automatic Control System

SYSTEMS FEATURES AND BASIC OPERATION

ROTATING LASER

The Automatic Control System can operate with many models of Rotating Lasers. The beacon must have a 360° rotating head with invisible or red beam and a speed of 8-40 RPS (Revolutions per Second). The faster the beacon's speed the more optimally the system will perform.

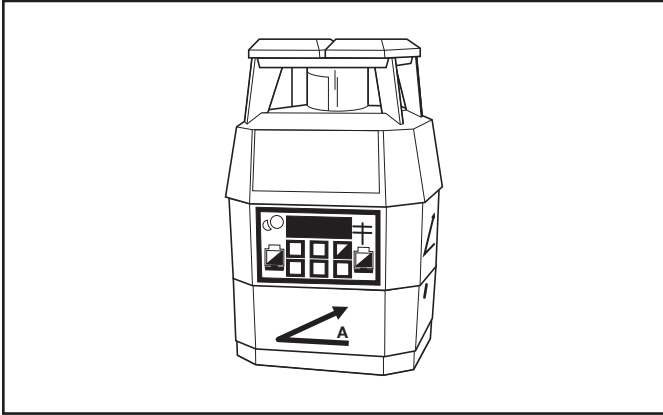

Figure 1-2. Rotating Laser

The Rotating Laser is mounted on a tripod, which is located on the job site near where the box is operating. The Rotating Laser is the unit that creates the plane of laser light detected by the Laser Receivers.

The Rotating Laser transmits a focused plane of laser light approximately 1000 feet (300 meters), optimal range for most Rotating Lasers, as it rotates.

Rotating Lasers are available in single grade, dual grade, and steep slope versions. They can be quickly and easily aligned to job site requirements without complicated calculation of angles.

A dual slope Rotating Laser can be configured for level, single slope, or dual slope applications. Simply enter the required percent of grade and align the Rotating Laser to the axis (direction) to be graded.

- Percent of Grade. The change in elevation for every 100 feet (30 meters) graded.
- Slope. The change in elevation per foot (meter).

damage. However, avoid looking into the beam whenever possible. Use a target for viewing the laser spot.

WARNING

Use of any laser on a worksite is controlled by OSHA regulations found at 29 CFR 1926.54. Be familiar with these regulations before using any laser beacon used in conjunction with this system. Review and understand all literature provided with the Laser System before operating.

WARNING

Laser protection devices must be provided to all workers in the area if the laser system exceeds five (5) milliwatts. Refer to the literature provided with the system to determine the power output. If unsure of the strength of the laser system, anti-laser eye protection should be provided to all workers.

JOB SITE SET-UP

The following are guidelines for setting up the Rotating Laser for both level job sites and sloped job sites:

- Choose a location for the Rotating Laser where obstructions, such as trees and buildings, can not block the plane of laser light. The Laser Receivers need to be able to sense the plane of laser light at all times.
- Whenever possible, set up the Rotating Laser and Laser Receivers at a height above the machine's cab. This prevents the cab or rollover structure from blocking the plane of laser light as the machine moves around the job sites.
- The recommended head speed for the Laser Receivers is 20 RPS (Revolutions per Second). At 20 RPS, the Rotating Laser updates the Laser Receivers 20 times per second.

WARNING

Never look directly into a laser light or serious injury to the eye may occur. In general, incidental exposure of the laser to the eye will not do

SYSTEMS FEATURES AND BASIC OPERATION

Set-Up for Level Grading

If the job site is to be level, the set-up of the Rotating Laser is simple. Since no slope is required in either axis, the Rotating Laser does not need to be aligned. The Rotating Laser will provide a level plane of laser light in all directions.

1. Locate the Rotating Laser following the previously stated guidelines.
2. Apply power to the Rotating Laser. Level the Rotating Laser (some Rotating Lasers will automatically level, others will need manual adjustment).
3. Set the counters for both axis at 0.000% (If needed, see the Rotating Laser Operation Manual).
4. Bench the machine. See the “Benching and Operating” procedure in this section.

Set-Up for Sloped Grading

If the job site is to be graded for a single or dual slope, the Rotating Laser requires its axis to be aligned for the job site. The Rotating Laser will then provide a plane of laser light at the required slope(s).

The following procedures are for two typical examples of job sites requiring sloped grades. Remember, each job site is unique, so consider the following methods as guidelines and not as the only methods possible.

Method One:

1. Set a minimum of two grade stakes exactly in line with one of the axis to be graded.
2. Place the Rotating Laser in line with the two grade stakes.

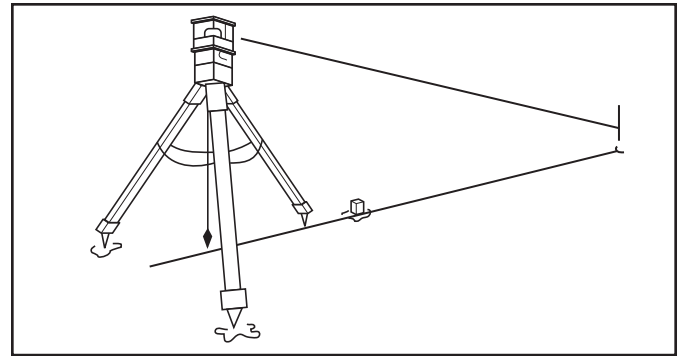

Figure 1-3. Method One: Align Rotating Laser with Grade Stakes

3. Switch on the Rotating Laser. Level the Rotating Laser (some Rotating Lasers will automatically level, others will need manual adjustment).
4. Set the counter on the Rotating Laser for both axis to 0.0000% (If needed, see the Rotating Laser Operation Manual).
5. Roughly align one of the axis to the grade stakes by sighting over the top of the Rotating Laser (Refer to Figure 1-6).

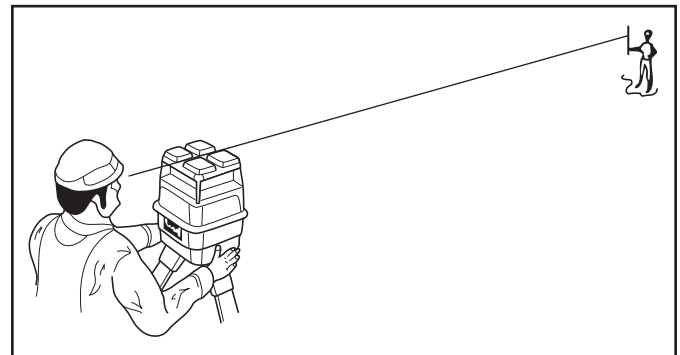

Figure 1-4. Sight over Rotating Laser

6. Align the plane of laser light.
 - a. Set a grade Rod with Rod Eye Receiver on the far grade stake and adjust the rod until the Rod Eye Receiver indicates “On Grade.”
 - b. On the axis not aligned with the stakes, enter on the Rotating Laser: 5.000%. Allow the Rotating Laser to level itself to this new position, if needed.
 - c. Check the Rod Eye Receiver again.
 - If the Rod Eye Receiver indicates “On Grade”, the plane of laser light is aligned correctly.

SYSTEMS FEATURES AND BASIC OPERATION

- If the Rod Eye Receiver indicates the plane of laser light is too high or too low, have a second person rotate the Rotating Laser on the tripod in small steps until the Rod Eye Receiver indicates “On Grade.”
7. Enter on the Rotating Laser the required percent of grade for each axis and allow the Rotating Laser to level itself again.
 8. Bench the machine. See the “Benching and Operating” procedure in this section.

Method Two:

1. Set a minimum of two surveyed grade stakes. The stakes must have elevation information (Refer to Figure 1-8).

NOTE: This procedure requires that the elevation of the grade stakes are correct and aligned to the slope or percent of grade required.

2. Place the Rotating Laser a few feet (meters) behind the first grade stake and in line with one of the far grade stakes (It is not critical to align the Rotating Laser exactly) (Refer to Figure 1-9).

NOTE: Follow the guidelines at the beginning of this section when placing the Rotating Laser.

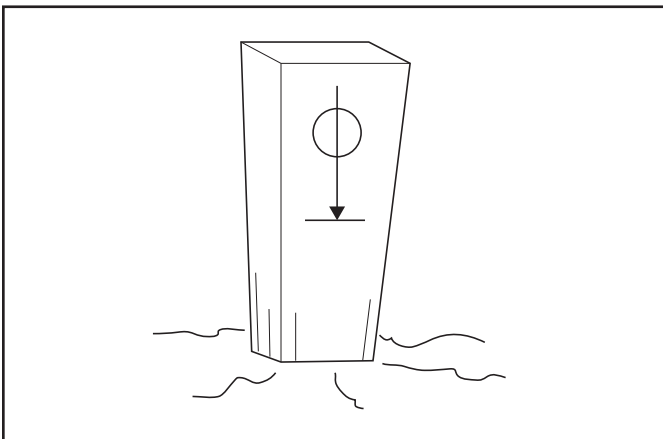

Figure 1-5. Grade Stake with Elevation Mark

3. Switch on the Rotating Laser. Level the Rotating Laser.
4. Roughly align one of the axis to the grade stakes by sighting over the top of the Rotating Laser (Refer to Figure 1-6).

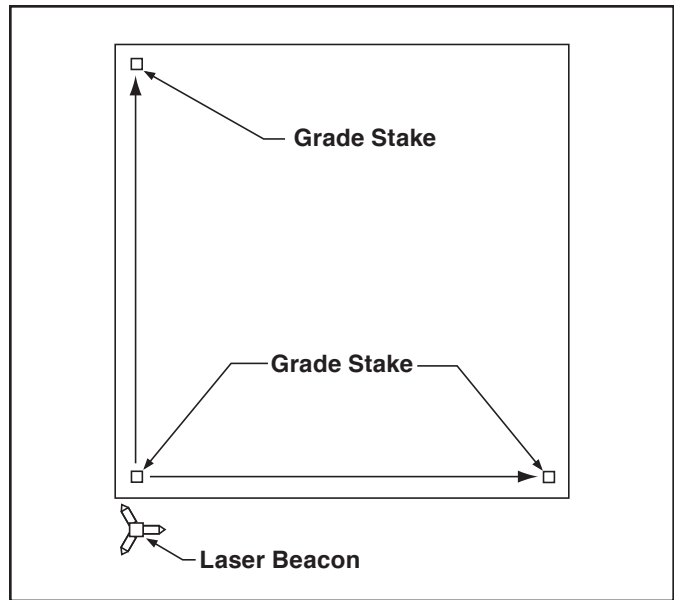

Figure 1-6. Method Two: Align Rotating Laser with Grade Stakes

5. Set both the counters on the Rotating Laser to the required percent of grade (If needed, see the Rotating Laser Operation Manual).

NOTE: The Grade Rod must be held plumb for each of the readings taken in the following steps.

6. Establish the H.I. (height of the instrument) for the plane of laser light.
 - a. Align the bottom of the Grade Rod to the mark on the near grade stake.
 - b. Adjust the Rod Eye Receiver up and down until it indicates “On Grade.”
 - c. Adjust the Rod Eye Receiver for any cut or fill amount indicated by the grade stake.
 - If the grade stake shows a cut, extend the Grade Rod and Rod Eye by the amount shown as a cut.
 - If the grade stake shows a fill, lower the Rod Eye by the amount shown as fill.
7. Align the plane of laser light.
 - a. Align the bottom of a Grade Rod to the mark on the far grade stake.
 - b. Check the Rod Eye Receiver.
 - If the Rod Eye Receiver indicates “On Grade,” the plane of laser light is aligned at the correct slope.

SYSTEMS FEATURES AND BASIC OPERATION

- If the Rod Eye Receiver indicates the plane of laser light is too high or too low, have a second person rotate the Rotating Laser on the tripod in small steps until the Rod Eye Receiver indicates “On Grade.”

NOTE: If it was necessary to rotate the Rotating Laser a significant amount at the far stake, then the original reading at the near stake may be out of tolerance. Check the setting again and make minor adjustments as required.

8. Bench the machine.

NOTE: If needed, check the elevations on both the plane of laser light and the grade stake elevations by setting the bottom of the Grade Rod at any stake’s grade mark and checking the Rod Eye Receiver for the “On Grade” indication.

BENCHING AND OPERATING

Before benching, the plane of laser light must be set at its proper slope. Benching is the process of setting the relationship between the Laser Receivers and Rotating Laser, or benchmark. Failure to properly bench the system before grading will result in an unacceptable grade.

The goal is to have the Laser Grading Box approximately 1/2 full during operation. If, during rough grading, a lot of material needs to be removed from a site, the Laser Receivers should be set several inches higher than finished grade. As material is removed, the Laser Receivers can be lowered and the site regraded. This may need to be repeated several times until finished grade is achieved.

Benching

1. Move the machine to an area which is close to finish grade or, using the manual controls on the control system, grade a small area close to finish grade.

NOTE: Finish grade can be checked several times during the grade process to “zero” in on final grade.

2. Set the Auto/Manual Switches to MANUAL.
3. Turn the Laser Receivers and Rotating Laser ON.
4. Raise the Power switch and hold in the I position for 1 second to access the User Setup menu.
5. From the User Setup screen on the Control Panel, highlight the Deadband (Accuracy) icon and press the joystick.
6. Select the next to narrowest deadband setting.
7. Press the joystick twice to exit the deadband setup.
8. Adjust the height of the Laser Receivers until the center (On-Grade) Grade Position LED clusters are lit. The mast pole tee handle is NOT to be loosened, loosen the Laser Receiver clamp and move the Receiver on the mast pole.

NOTE: Most materials graded must later be compacted. To compensate for the compacting distance, lower both Laser Receivers equally. This raises the box’s cutting edge by the same distance. The distance the Laser Receivers are lowered depends on the material.

Benching with a Rod Eye

To bench the Laser Receivers using a Rod Eye, follow the process listed below:

1. Turn on the Rotating Laser. Attach a Rod Eye to a measuring pole and turn on. Set the base of the measuring pole on the benchmark and adjust the measuring pole so the Rod Eye emits a solid “On Grade” tone (compensate for slab thickness and compaction if needed).
2. Find an area to be graded that is close to specified grade. Start the tractor, engage the auxiliary hydraulics and position the unit so one end of the cutting edge is in that location. Manually raise or lower the Laser Grading Box’s cutting edge until it is even with the bottom of the measuring pole when the Rod Eye is emitting the “On Grade” tone or resting on the ground if already at grade.

SYSTEMS FEATURES AND BASIC OPERATION

3. Making sure the Control Panel's Automatic/Manual Switch is on Manual and the On-Grade Deadband is set correctly (refer to steps 4 thru 7 in Benching) move the Laser Receiver to a height on the mast pole where it indicates the beam in the "On Grade" position and is unobstructed by any object.

NOTE: Operator may prefer to turn the face of the Laser Receiver towards the operator for easy viewing.

4. Repeat steps 2 and 3 for the other end of the cutting edge, moving either the machine or the measuring pole.

The Laser Grading Box Automatic Control System is now calibrated.

Operation

After the Laser Grading Box is connected and the Automatic Control System is calibrated, operation can begin.

The operational goal is to drive over the area to be graded with the box 1/2 full of material and the Control Panel's green light always illuminated.

1. When seated in the Operator's seat, start the tractor and set both Auto/Manual switches to AUTO.
2. Set the Deadband to a mid range setting.

NOTE: Most materials graded must later be compacted. To compensate for the compacting distance, lower both Laser Receivers an equally. This raises the box's cutting edge by the same distance. The distance the Laser Receiver is lowered will depend on the material.

3. Drive the machine forward. The Automatic Control System constantly senses the plane of laser light, raising and lowering each end of the grading box to maintain the cutting edge at the required elevation. Note the following during operation:

- In some situations, the Automatic Control System may require a cut deeper than the machine can handle. The machine may lose traction, stall the engine, or the wheel

frame will be lifted off the ground to the maximum stroke of the cylinder as the cutting edge tries to reach finished grade. If this occurs, set the Auto/Manual switches to MANUAL and use the Raise/Lower switches to raise the cutting edge until the machine can push the material. Make multiple passes to cut the area closer to finished grade and then go back to AUTO control. This allows the high spots to be gradually removed.

- If one of the Control Panel's or Laser Receiver's grade lights are blinking, it indicates the direction of the last elevation prior to passing out of the laser beam. Readjust the height of the Grading Box manually until the signal is found. The Laser Receiver or Rotating Laser height may need to be adjusted if this situation continues to occur or switch to MANUAL operation until you get closer to grade.

NOTE: In rough grading situations, use the Automatic Control System as an "Indicate Only" system and operate the machine under manual control. After the area has been rough graded, switch to automatic control.

4. After several passes with the Laser Grading Box, stop and turn off the tractor. Place the base of the measuring pole on the graded area and check grade elevation.
5. After a rough grade is achieved, the On-Grade Deadband setting may be changed to a narrower setting as required to meet the job tolerance requirements. With a tighter deadband, the speed of the tractor needs to be decreased for optimum finish.

SYSTEMS FEATURES AND BASIC OPERATION

SPECIFICATIONS AND MAINTENANCE

Dimensions

Model	SC48	SC60
Box Width	48 in. (123 cm)	60 in. (152 cm)
Overall Width	50 in. (127 cm)	62 in. (157 cm)
Total Length	42.4 in. (108 cm) 76.4 in. (194 cm) with optional drawbar	
Box Capacity	4.1 ft ³ (0.11 m ³)	5.1 ft ³ (0.14 m ³)
Weight	345 lbs. (156 kg)	395 lbs. (179 kg)

SC Series Hydraulic Valve

Valve Type	Danfoss MVB10 Proportioned
Minimal Flow Rate	10 GPM (37.8 LPM)
Maximum Hydraulic Pressure	4060 psi (280 bar)

SYSTEMS FEATURES AND BASIC OPERATION

MAINTENANCE

The rugged and durable Automatic Control System is built to last, but as with all equipment, a few minutes of routine care, maintenance, and cleaning can extend the life of the system.

Storage and Transport

Most often the grading box and its hydraulic controls remain on your machine. However, you should store the Control Panel, Laser Receiver, Coiled Receiver Cable and Solenoid Cable in a safe place when not in use. Protect the cable connections by installing the covers supplied.

Cleaning

The Laser Receiver is completely sealed and purged with dry nitrogen. It requires no maintenance other than periodic checking to be sure its mounting structure is tight and secure.

The Control Panel is water resistant. It can be cleaned with mild soap and water, and a soft cloth. Do not submerge the Control Panel or direct high pressure spray at it. Do not use a dry cloth to wipe the Laser Receiver or Control Panel as scratching may occur.

Cables and Hoses

Check all cables and hoses regularly for signs of wear and damage. Keep cable connections clean and free from dirt and corrosion. If a cable has been damaged, do not attempt to repair. Incorrect or poor connections can cause damage to your Automatic Control System.

When applicable, check the hydraulic hoses. Look for areas where the hoses could rub against each other or another object as they expand and contract under pressure. Check the hydraulic fittings for tightness.

Machine

Check areas that affect the Automatic Control system function and accuracy, such as looseness or play in the cylinders or wear on the box's cutting edge. Looseness in the connection to the tractor, such as in the 3-point hitch, will cause inaccurate depth positioning.

Also check the tractor routinely for wear to its components, such as the 3-point linkage, ensuring it is operating properly.

Calibration

Perform periodic calibration checks of the Rotating Laser System, as outlined in its Operation Manual, to ensure accurate performance.

SERVICE

If the Automatic Control System is not functioning properly, the first step is to determine the problem component. Use the Troubleshooting Chart to determine possible causes and remedies. The following test equipment is needed:

- Voltage/Ohm Meter
- Rotating Laser or Laser Simulator

The Control Panel provides diagnostic codes to aid in troubleshooting and diagnostics. If a 5-digit code appears, contact ATI Group, LLC for assistance in diagnosing the code.

If the code 1505 appears, it indicates communication with the laser receiver(s) has been lost. Check the cable connections.

CAUTION

To prevent serious damage to the Automatic Control System, never replace a fuse with a fuse that has a higher amperage value.

CAUTION

The Automatic Control System is a highly sophisticated electronic system. Do not attempt repairs to the components. Contact your local dealer if you have any problems.

SYSTEMS FEATURES AND BASIC OPERATION

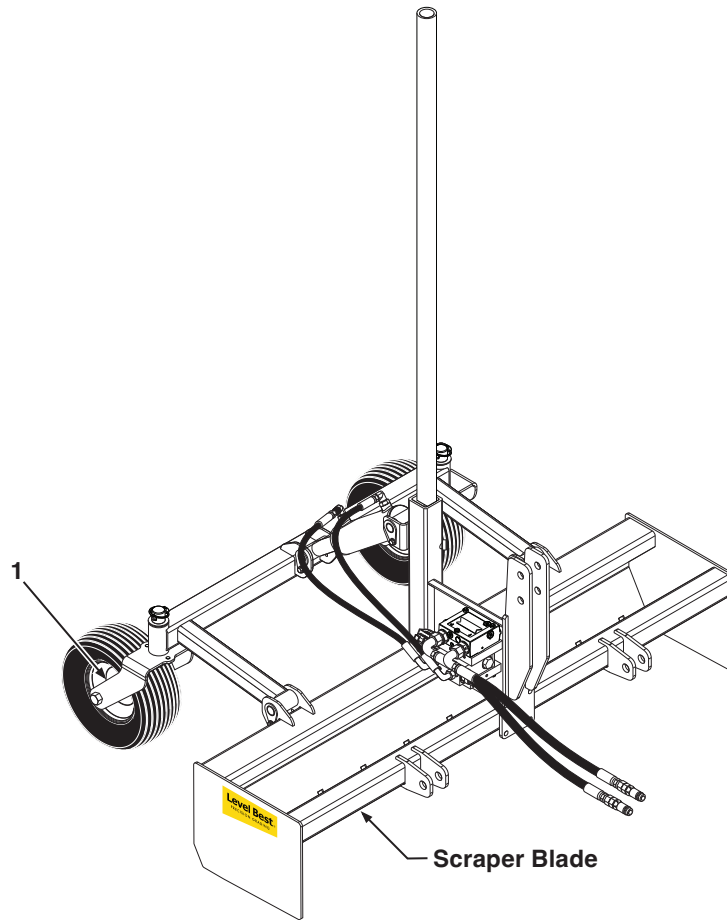

ITEM	NAME	FREQUENCY	LUBE TYPE
1.	Wheel Hub (2)	Annually	EP*
* EP - Multi-Purpose Grease.			

NOTES:

1. Check Hydraulic System Components for wear and/or leaks.
2. Check and tighten all bolts and nuts for scraper blade and end blades, weekly.

Figure 1-7. Lube and Maintenance Chart

(for future use)

TROUBLESHOOTING

SYMPTOM	POTENTIAL CAUSE	REMEDY
Control Panel lamps do not light.	<p>Control Panel not turned on.</p> <p>Power Cable not connected to Control Panel.</p> <p>Power Cable not providing power to the Control Panel.</p> <p>Fuse blown.</p> <p>Electrical short.</p>	<p>Toggle the Power Switch upward (I i).</p> <p>Connect power cable to Control Panel.</p> <p>Check that the Power Cable is connected to the battery. The red wire connects to the positive (+) post and the black wire connects to the negative (-) post.</p> <p>Remove the Power Cable from the Control Panel and use a volt meter to check for 12 volts DC.</p> <p>Check the fuse.</p> <p>Disconnect all cables except the Power Cable. If the lamps still do not cycle when the Control Panel is turned on, contact the local Apache Technologies dealer.</p>
Laser Receiver does not display grade.	<p>No Rotating Laser in range.</p> <p>Laser beam blocked.</p> <p>Laser Receiver not receiving power.</p> <p>Electrical short.</p>	<p>Ensure Laser Receiver is within operating range of Rotating Laser.</p> <p>Ensure beam is striking middle of the Laser Receiver</p> <p>Check and clean glass covering the Laser Receiver's photo cells.</p> <p>Check for obstructions keeping Laser Receiver from seeing the Rotating Laser.</p> <p>Check Fuse in the Control Panel.</p> <p>Check Receiver Cable for damage. Use an Ohm meter to check continuity</p> <p>If LEDs do not cycle when Control Panel is turned On, contact the local Apache Technologies dealer.</p>

Troubleshooting

TROUBLESHOOTING

SYMPTOM	POTENTIAL CAUSE	REMEDY
Laser Grading Box does not raise or lower.	Control Panel not turned on.	Toggle the Power Switch upward (I i).
	No hydraulic flow to Laser Grading Box.	Ensure hydraulic control handle of tractor is in correct position. Ensure auxiliary hydraulics are ON or in continuous flow mode.
	Cables not connected correctly.	Check Solenoid Cable and directional valve for visible damage. Move directional valve spool manually using the overrides on the end of the directional valve.
	Electrical Problems	<div style="border: 1px solid black; background-color: #ff9900; padding: 2px; text-align: center; margin-bottom: 5px;">  WARNING </div> <p>Be sure to stay clear of any moving parts of the Laser Grading Box.</p> <p>If the Laser Grading Box moves, refer to Electrical problems. If the Laser Grading Box does not move, refer to Hydraulic problems.</p>
Hydraulic problems.	Check the Solenoid Cable and directional valve for visible damage. Use an Ohm meter to check cable for continuity. Confirm hydraulic flow through the manifold and returning to the power source through the “T” hose. Contact ATI Group, LLC for help troubleshooting the hydraulic manifold.	
Laser Grading Box moves in opposite direction.	Hydraulic flow reversed.	Confirm the pressure is going in the “P” port. Verify control handle is moving in desired direction.

TROUBLESHOOTING

SYMPTOM	POTENTIAL CAUSE	REMEDY
Laser Grading Box does not seem to cut even across passes.	Control Panel to valve body connections are reversed.	Reverse cable connections so left-side Valve cable is connected to left-side valve body. Repeat for right side.
	Control Panel to Laser Receiver connections are reversed.	Reverse cable connections so left-side Laser Receiver is connected to the L connector on the Junction Block. Repeat for right side.
Box has trouble staying on grade.	Rotating Laser out of range.	Ensure Laser Receiver is within specified operating range of Rotating Laser.
	Laser beam being reflected.	Ensure Rotating Laser's light is not reflecting off other surfaces (windows, windshields, mirrors, etc.) causing multiple readings by the Laser Receiver.
	Multiple laser beams.	Ensure that there are no other lasers operating on the job site or nearby.
	Laser deadband set too narrow.	Ensure the On Grade Deadband is set for rough grading.
	Travel speed is too fast for grade tolerance.	Slow down.
	Hydraulic response too quick.	Decrease the Hydraulic Speed setting.
	Hydraulic flow reversed.	Confirm the pressure is going in the "P" port.

TROUBLESHOOTING

(for future use)

PARTS ILLUSTRATIONS

Parts Illustrations	3.1
Serial Number Information	3.2
Where To Get Parts and Service	3.2
How To Order Parts	3.2
List of Parts Illustrations	3.3

PARTS ILLUSTRATIONS

Serial Number Information

It is very important that the correct serial number is provided when ordering parts. The serial number plate is located on the main frame. Please mark the model and serial number of your Laser Grading Box in the space provided below in case the plate on your Laser Grading Box gets lost or damaged.

Model..... **Serial Number**

Dealer Name **Dealer Phone Number**

Where To Get Parts and Service

When replacement parts and service are required, ATI Group, LLC recommends returning to the dealer from which the product or optional kit was purchased. By going to the dealer, you are dealing with people that understand and know ATI products. Our dealers have the experience servicing these machines and stock the most common parts required to keep your equipment in top working condition.

How To Order Parts

Parts lists contained in this book have been prepared to help you when ordering spare and/or replacement parts. Your order will be filled promptly and accurately when the following information is provided:

1. Model and serial number of the unit. (This specifically identifies the equipment you have and permits us to verify the part numbers in your order.)
2. The parts list page number and catalog number. Include catalog revision number, if applicable.
3. The **Item** number for each part. **Item** numbers on the parts list page correspond with the numbers shown on the illustration.
4. **Part Number** as it appears in the parts list. In most cases this will be a nine-digit number; for example: 315-005-000.
5. The **Description** for the part as it appears on the parts list page.

When a complete assembly is needed, use the assembly number given in the parts list. If no assembly number is given, order by main assembly title and list only the item numbers you want. For example: “Wheel Frame Assembly per 315-509-000, Items 2 through 8, inclusive”.

The part ordered may have a new part number, or the part may have been replaced by a newer design with a different part number. In these cases your acknowledgement, shipping papers and invoices will be written listing the current part number first; the old part number you referred to will follow the part description.

Our purpose in doing this is to tell you that the parts are fully interchangeable. This will avoid any unnecessary correspondence or delay in processing your order. We suggest that you add any new number to your parts lists for future use.

NOTE: ATI Group, LLC reserves the right to discontinue models at any time, change specifications, and improve design without notice and without incurring obligation on goods previously purchased and to discontinue supplying any part listed, when the demand does not warrant production.

LIST OF PARTS ILLUSTRATIONS

Figure 3-1.	Main Frame and Cutting Edges	3.4
Figure 3-2.	Wheel Frame and Related Parts	3.6
Figure 3-3.	Caster Fork and Wheel.....	3.8
Figure 3-4.	Hydraulic Cylinder Only.....	3.10
Figure 3-5.	Hydraulic With Optional Valve Assembly	3.12
Figure 3-6.	Hydraulic Valve Assembly.....	3.14
Figure 3-7.	Laser Controls and Related Parts - Spectra.....	3.16
Figure 3-8.	Control Panel, Receiver, Cables - Spectra	3.18
Figure 3-9.	Drawbar, with Wheel Locks	3.20
Figure 3-10.	Decals.....	3.22

PARTS ILLUSTRATIONS

Figure 3-1. Main Frame and Cutting Edges

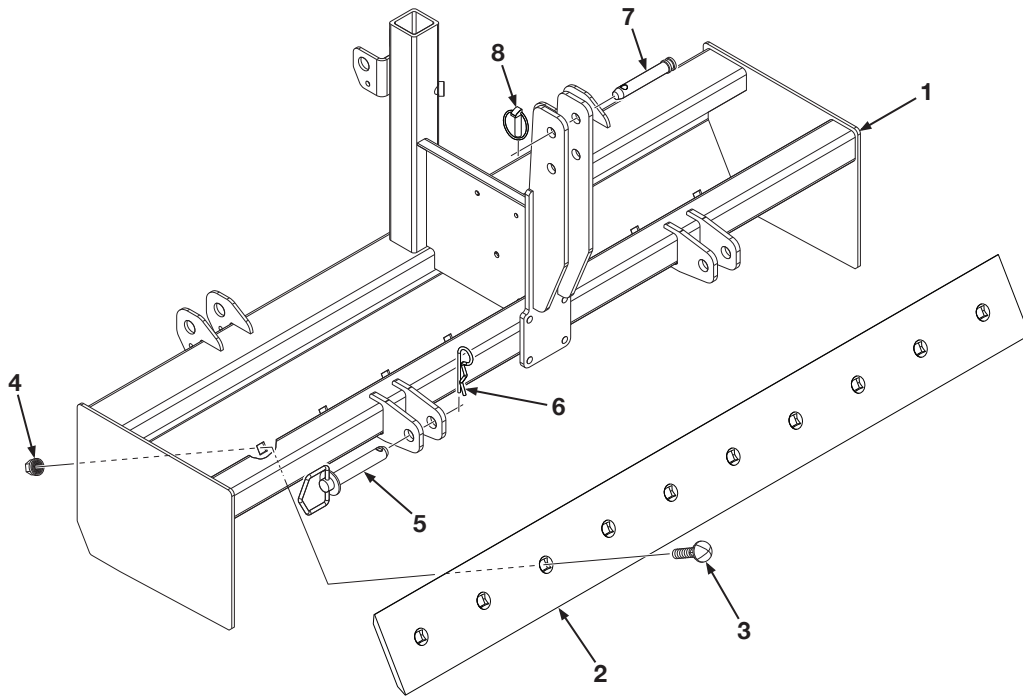

PARTS ILLUSTRATIONS

Figure 3-1. Main Frame and Cutting Edges

Item	Part No.	Qty	Description
1	315-070-600	1	Frame, Main 48"
	315-072-600	1	Frame, Main 60"
2	000-190-162	1	Edge, Cutting, Bolt-On, DBF, 48"
	000-190-128	1	Edge, Cutting, Bolt-On, DBF, 60"
3	000-150-258	AR	Bolt, Plow, 5/8"-11UNC x 1/3/4" Long
4	000-158-142	AR	Nut, Hex, Serrated Flange, 5/8"-11UNC
5	000-161-076	2	Pin, Hitch, Cat. I, 7/8" Dia. x 5-1/4" Long
6	000-161-019	2	Cotter, Hairpin, .177" Dia. Wire x 3-3/4" Long
7	000-161-080	1	Pin, Top Link, Cat. I, 3/4" Dia. x 4-1/2" Long
8	000-161-028	1	Pin, Lynch, Locking, 7/16"

AR - As Required NSS - Not Serviced Separately ASN - After Serial No. BSN - Before Serial No. LP - Local Purchase

PARTS ILLUSTRATIONS

Figure 3-2. Wheel Frame and Related Parts

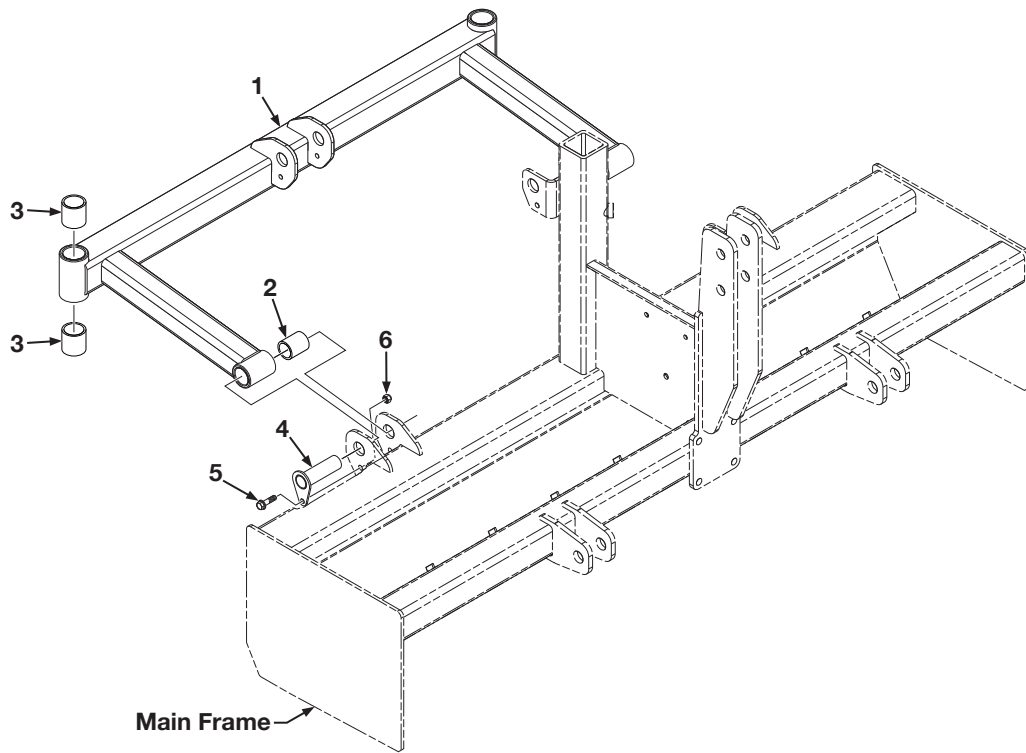

PARTS ILLUSTRATIONS

Figure 3-2. Wheel Frame and Related Parts

Item	Part No.	Qty	Description
1	315-072-700	1	Frame, Wheel, 3-Pt, Includes Item 2 & 3
2	000-176-174	AR	Bushing, 1-1/4" OD x 1" ID x 1" Long
3	000-176-177	4	Bushing, 1-1/2" OD x 1-1/4" ID x 1-1/2" Long
4	000-161-204	2	Pin, 1" Dia x 3-7/16" OAL, w/Tab
5	000-150-078	2	Bolt, Serrated Flange, 5/16"-18UNC x 1" Long
6	000-158-223	2	Nut, Lock, Flange, Nylon-Insert, 5/16"-18UNC

AR - As Required NSS - Not Serviced Separately ASN - After Serial No. BSN - Before Serial No. LP - Local Purchase

PARTS ILLUSTRATIONS

Figure 3-3. Caster Fork and Wheel

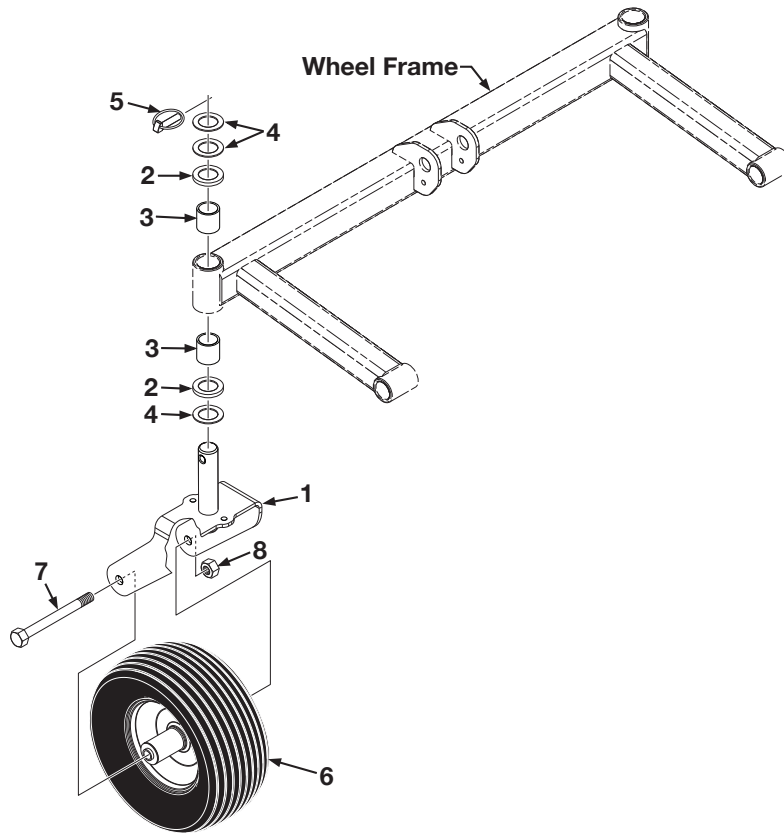

PARTS ILLUSTRATIONS

Figure 3-3. Caster Fork and Wheel

Item	Part No.	Qty	Description
1	315-607-000	2	Fork, Caster
2	000-155-012	4	Bushing, Washer, 2" OD x 1-9/32" ID x 16 Gauge
3	000-176-177	4	Bushing, 1-1/2" OD x 1-1/4" ID x 1-1/2" Long
4	314-001-610	6	Washer, Spacer, 1/4"
5	000-161-028	1	Pin, Lynch, Locking, 7/16"
6	001-001-100	2	Wheel/Tire, 13/6.50-6, White Wheel
7	000-150-284	2	Bolt, Hex Head, 5/8"-11UNC x 7-1/2" Long
8	000-158-140	2	Nut, Hex, Nylon Lock, 5/8"-11UNC

AR - As Required NSS - Not Serviced Separately ASN - After Serial No. BSN - Before Serial No. LP - Local Purchase

PARTS ILLUSTRATIONS

Figure 3-4. Hydraulic Cylinder Only

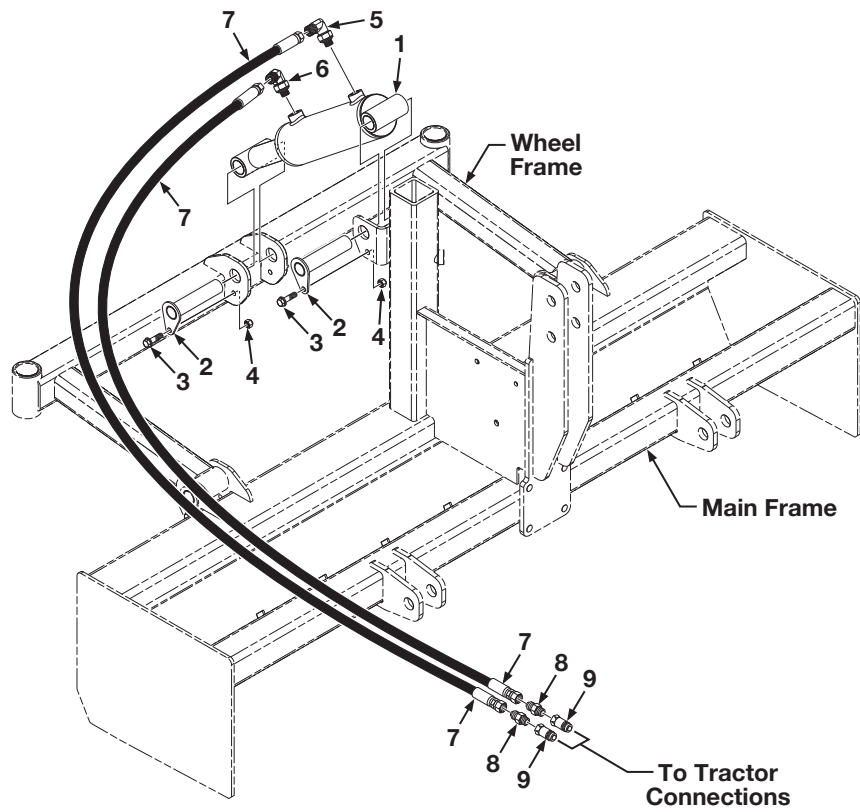

PARTS ILLUSTRATIONS

Figure 3-4. Hydraulic Cylinder Only

Item	Part No.	Qty	Description
1	000-166-680	1	Cylinder, Hydraulic, 3" Bore x 6" Stroke
2	000-161-168	2	Pin, 1" Dia x 4-5/8" OAL, w/Tab
3	000-150-078	2	Bolt, Serrated Flange, 5/16"-18UNC x 1" Long
4	000-158-223	2	Nut, Lock, Flange, Nylon-Insert, 5/16"-18UNC
5	000-166-748	1	Elbow, 90°, 6MJ x 6MB, With Orifice
6	000-166-225	1	Elbow, 90°, 6MJ x 6MB
7	000-166-453	2	Hose, 1/2" Dia. x 90" Long x 6FJX x 8FJX, 3,000 PSI
8	000-166-168	2	Adapter, Straight, 8MJ x 8MP
9	000-166-210	2	Coupler, Quick Disconnect, Ag, Male, 1/2"
			BH-Bulkhead MP-Male Pipe FP-Female Pipe FPX-Female Pipe Swivel MB-Male O-Ring Boss FB-Female O-Ring Boss MJ-Male JIC FJ-Female JIC FJX-Female JIC Swivel

AR - As Required NSS - Not Serviced Separately ASN - After Serial No. BSN - Before Serial No. LP - Local Purchase

PARTS ILLUSTRATIONS

Figure 3-5. Hydraulic With Optional Valve Assembly

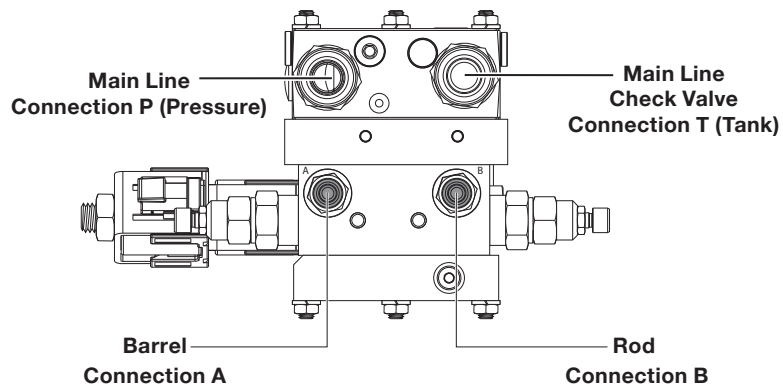
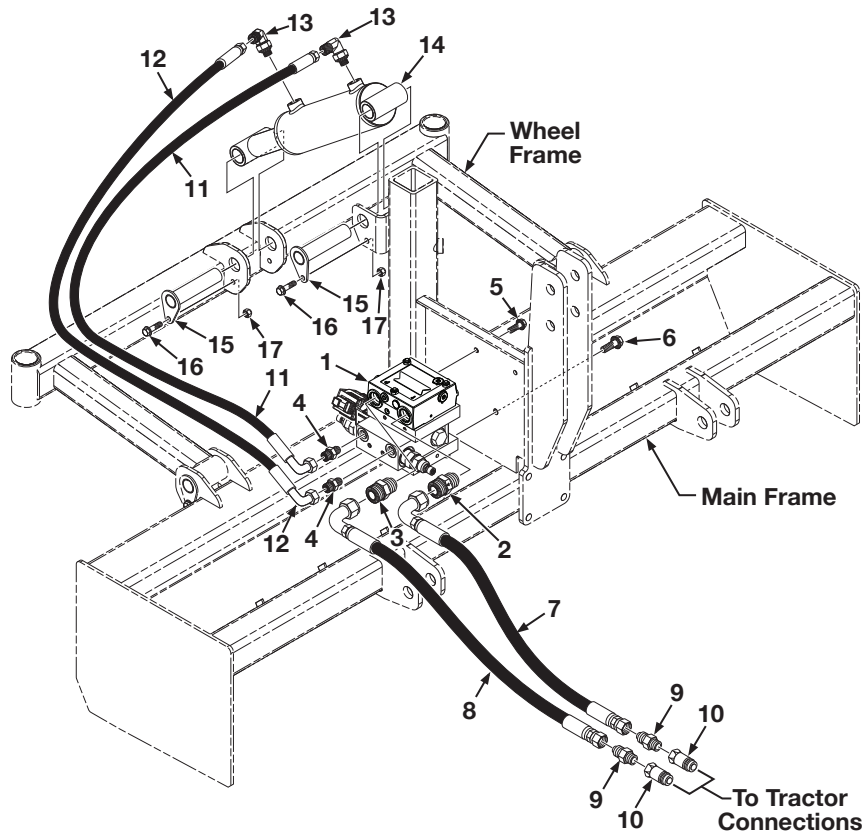

Top View Hydraulic Valve

PARTS ILLUSTRATIONS

Figure 3-5. Hydraulic With Optional Valve Assembly

Item	Part No.	Qty	Description
1	000-166-874	1	Valve Assembly, Hydraulic MVB10, Includes Items 2 & 3, See Breakdown Figure 3-6
2	000-166-824	1	Valve, Check, 12OFS x 12MB, (DO NOT REMOVE FROM ITEM 1)
3	000-166-694	1	Fitting, Adapter, 12OFS x 12MB
4	000-166-685	2	Fitting, Adapter, 6OFS x 6MB
5	000-150-074	2	Bolt, Serrated Flange, 5/16"-18UNC x 3/4" Long
6	000-150-119	1	Bolt, Serrated Flange, 3/8"-16UNC x 3/4" Long
7	000-166-908	1	Hose, 5/8" Dia x 42" L x 10MORB x 12FOFX90, 4,060 PSI
8	000-166-908	1	Hose, 5/8" Dia x 42" L x 10MORB x 12FOFX90, 4,060 PSI
9	000-166-884	2	Adapter, Straight, 10FB x 8MP,
10	000-166-210	2	Coupler, Quick Disconnect, Ag, Male, 1/2"
11	000-166-896	1	Hose, 3/8" Dia. x 29" Long x 6FOFX x 6FOFX90, 3,000 PSI
12	000-166-896	1	Hose, 3/8" Dia. x 29" Long x 6FOFX x 6FOFX90, 3,000 PSI
13	000-166-697	2	Elbow, 90°, 6OFS x 6MB
14	000-166-680	1	Cylinder, Hydraulic, 3" Bore x 6" Stroke
15	000-161-168	2	Pin, 1" Dia x 4-5/8" OAL, w/Tab
16	000-150-078	2	Bolt, Serrated Flange, 5/16"-18UNC x 1" Long
17	000-158-223	2	Nut, Lock, Flange, Nylon-Insert, 5/16"-18UNC
			BH-Bulkhead MP-Male Pipe FP-Female Pipe FPX-Female Pipe Swivel FFX- Female O-Ring Flat Face Swivel MB-Male O-Ring Boss FB-Female O-Ring Boss MJ-Male JIC FJ-Female JIC FJX-Female JIC Swivel OFS-O-Ring Face Seal OFSBH-O-Ring Face Seal Bulkhead

AR - As Required NSS - Not Serviced Separately ASN - After Serial No. BSN - Before Serial No. LP - Local Purchase

PARTS ILLUSTRATIONS

Figure 3-6. Hydraulic Valve Assembly

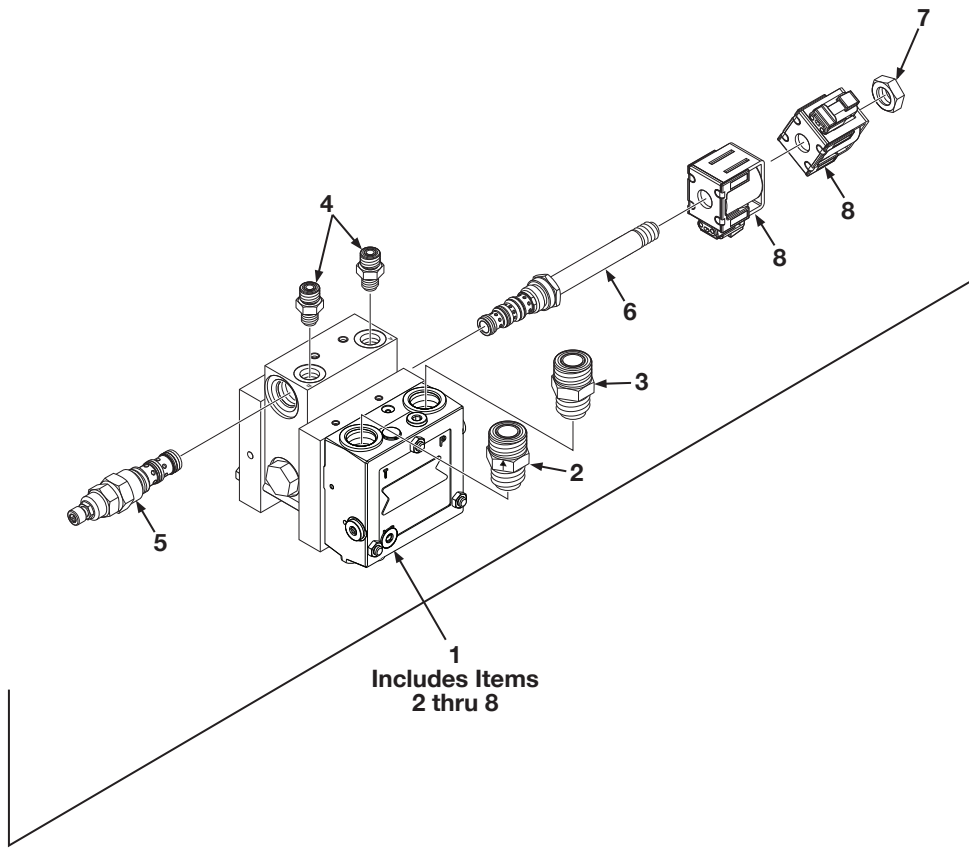

PARTS ILLUSTRATIONS

Figure 3-6. Hydraulic Valve Assembly

Item	Part No.	Qty	Description
1	000-166-874	1	Valve Assembly, Hydraulic MVB10, Includes Items 2 thru 8
2	000-166-824	1	Valve, Check, 12OFS x 12MB, (DO NOT REMOVE FROM ITEM 1)
3	000-166-694	1	Fitting, Adapter, 12OFS x 12MB
4	000-166-685	2	Fitting, Adapter, 6OFS x 6MB
5	000-166-844	2	Valve, Counter Balance
6	NSS	1	Stem, Includes Item 7
7	NSS	1	Nut
8	000-166-843	2	Coil

AR - As Required NSS - Not Serviced Separately ASN - After Serial No. BSN - Before Serial No. LP - Local Purchase

PARTS ILLUSTRATIONS

Figure 3-7. Laser Controls and Related Parts - Spectra

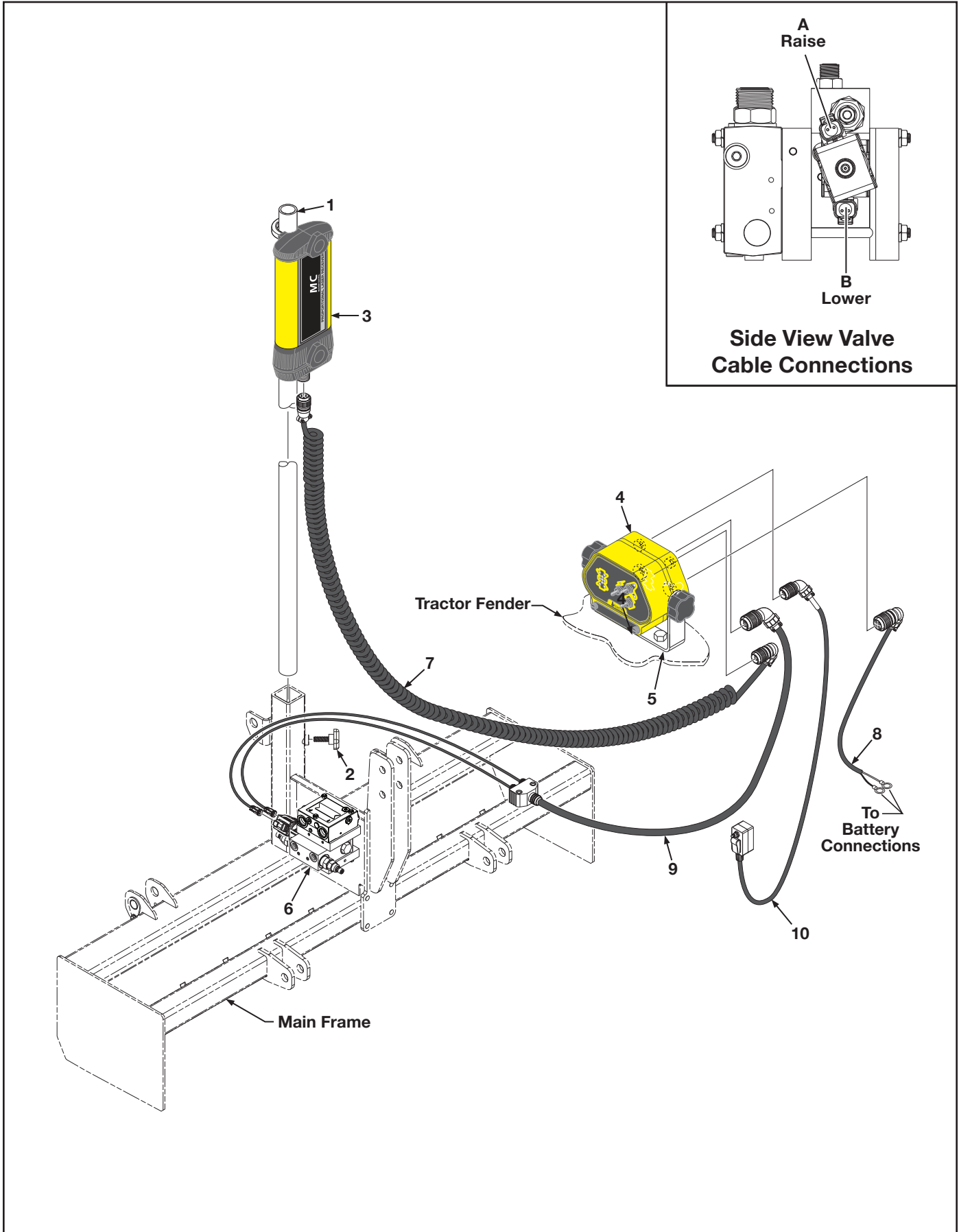

PARTS ILLUSTRATIONS

Figure 3-7. Laser Controls and Related Parts - Spectra

Item	Part No.	Qty	Description
1	001-001-105	1	Pole, Mast, Sectional, 1-1/2" Dia. x 84" Long
2	001-001-053	1	Handle, Tee
3	000-200-275	1	Receiver, Laser 360°, Spectra B5MC Yellow
4	000-200-211	1	Panel, Control, Spectra CB25, Yellow, See Breakdown Figure 3-8
5	001-001-075	1	Bracket, Control Panel
6	000-166-874	1	Valve Assembly, Hydraulic MVB10, See Breakdown Figure 3-6
7	000-200-099	1	Cable, Receiver, Coiled, 15' Long
8	000-200-097	1	Cable, Power, 2-Wire, 20' Long
9		1	Cable, Solenoid, 90°, 16' Long, Spectra CB25
10	000-200-158	1	Switch Assembly, Remote, Auto/Manual, Raise/Lower, 10' Long

AR - As Required NSS - Not Serviced Separately ASN - After Serial No. BSN - Before Serial No. LP - Local Purchase

PARTS ILLUSTRATIONS

Figure 3-8. Control Panel, Receiver, Cables - Spectra

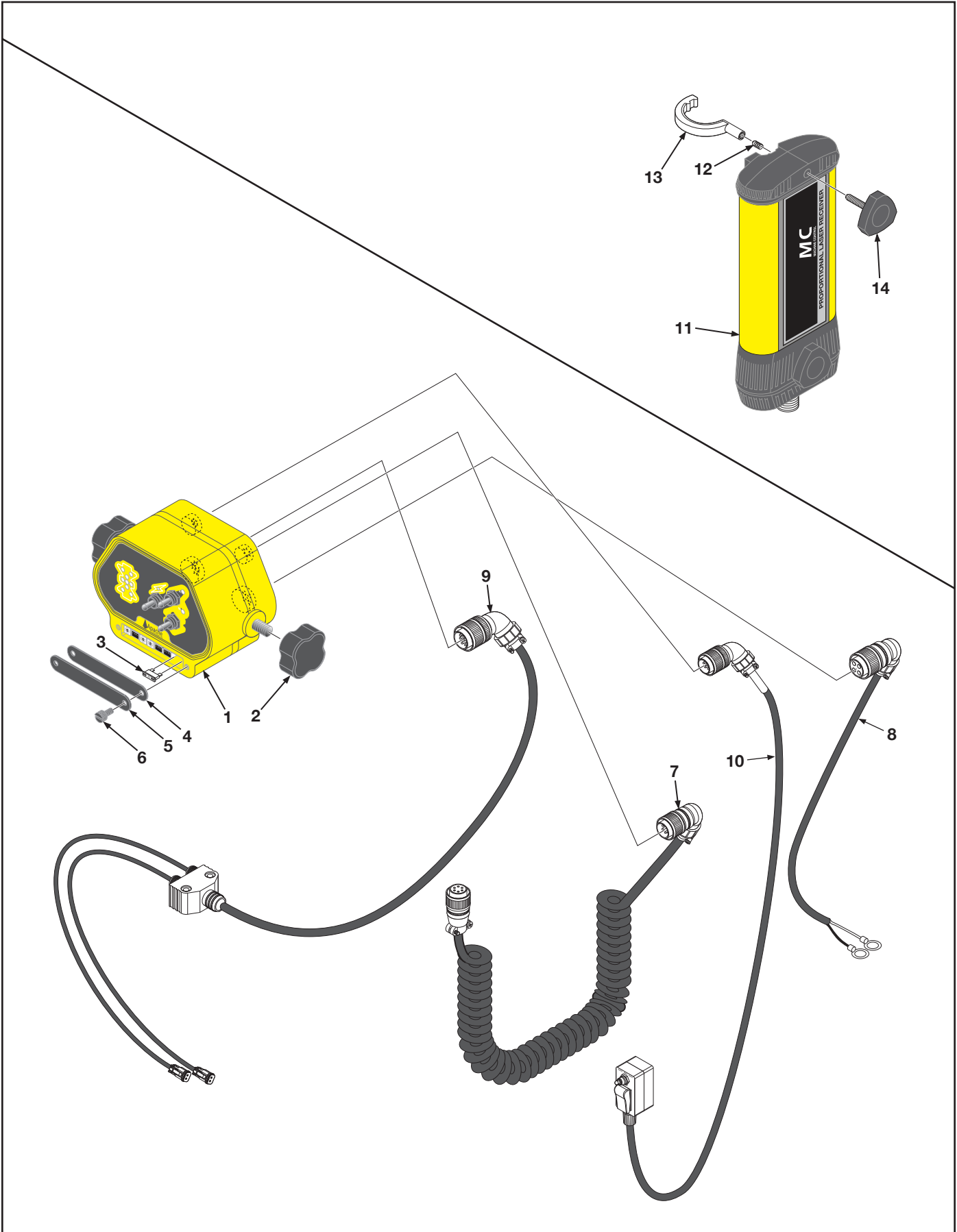

PARTS ILLUSTRATIONS

Figure 3-8. Control Panel, Receiver, Cables - Spectra

Item	Part No.	Qty	Description
1	000-200-211	1	Panel, Control, Spectra CB25, Includes Items 2 thru 6
2	000-200-112	2	Knob
3	LP	1	Fuse, 25 Amp
4	000-200-115	1	Gasket, Front Cover Plate
5	000-200-114	1	Plate, Front Cover
6	000-200-113	2	Screw, Thumb
7	000-200-099	1	Cable, Receiver, Coiled, 15' Long
8	000-200-097	1	Cable, Power, 2-Wire, 20' Long
9		1	Cable, Solenoid, 90°, 16' Long, Spectra CB25
10	000-200-158	1	Switch Assembly, Remote, Auto/Manual, Raise/Lower, 10' Long
11	000-200-275	1	Receiver, Laser 360°, Spectra B5MC Yellow, Includes Items 11 thru 14
12	000-161-094	2	Spring, Clamp, Compression
13	000-200-108	2	Clamp, Universal, 2" Dia.
14	000-200-107	2	Knob, Clamp

AR - As Required NSS - Not Serviced Separately ASN - After Serial No. BSN - Before Serial No. LP - Local Purchase

PARTS ILLUSTRATIONS

Figure 3-9. Drawbar, with Wheel Locks

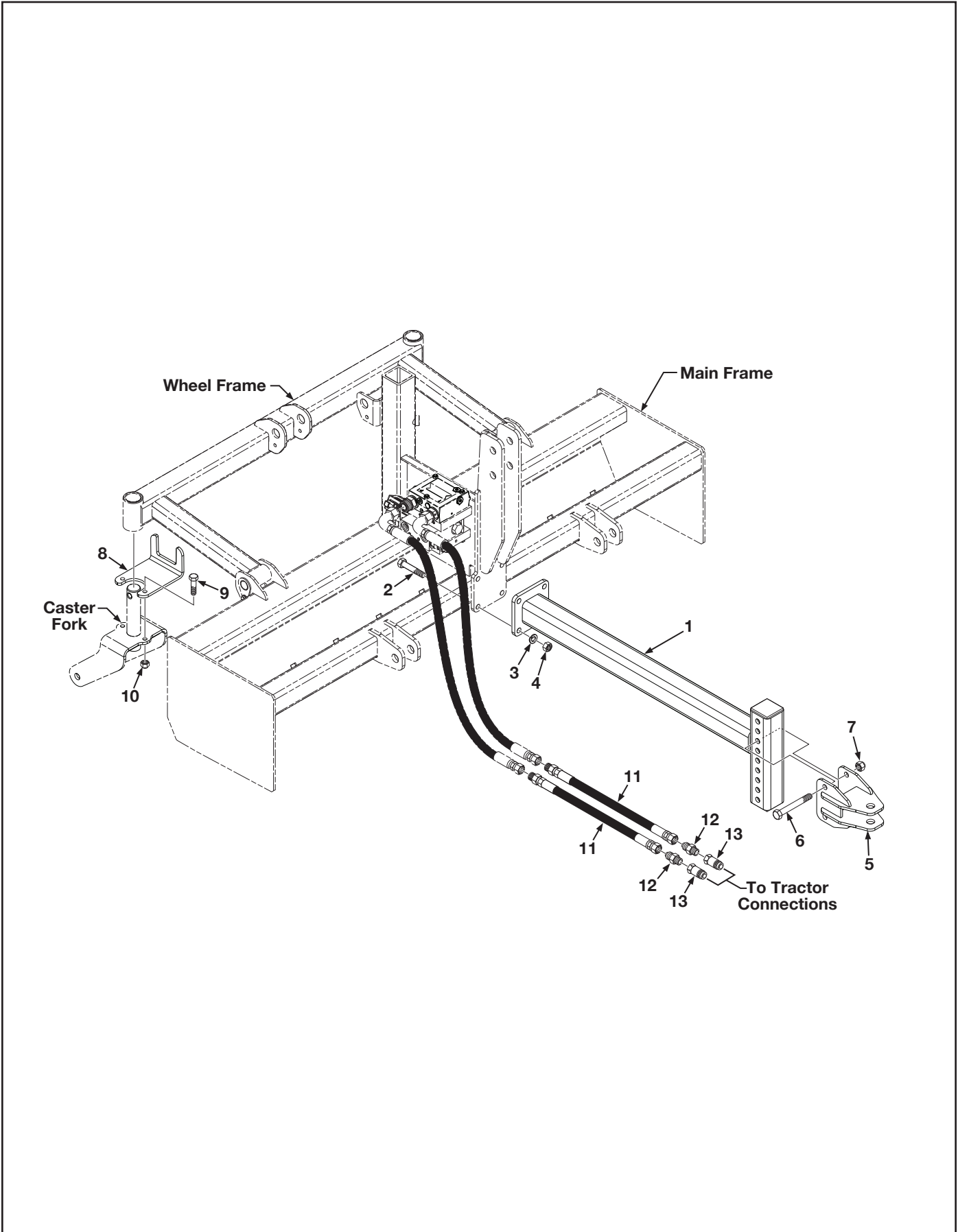

PARTS ILLUSTRATIONS

Figure 3-9. Drawbar, with Wheel Locks

Item	Part No.	Qty	Description
1	315-586-000	1	Drawbar
2	000-150-182	4	Bolt, Hex Head, 1/2"-13UNC x 1-3/4" Long
3	000-155-058	4	Washer, Lock, 1/2"
4	000-158-109	4	Nut, Hex, 1/2"-13UNC
5	315-587-000	1	Hitch, Clevis
6	000-150-213	2	Bolt, Hex Head, 1/2"-13UNC x 4" Long
7	000-158-113	2	Nut, Hex, Nylon Lock, 1/2"-13UNC
8	315-582-001	2	Plate, Wheel Lock
9	000-150-127	4	Bolt, Hex Head, 3/8"-16UNC x 1-1/4" Long
10	000-158-084	4	Nut, Hex, Nylon Lock, 3/8"-16UNC
11	000-166-829	2	Hose, 1/2" Dia x 20" Long x 6FJX x 8MJ, 5,000 PSI
12	000-166-168	2	Adapter, Straight, 8MJ x 8MP
13	000-166-210	2	Coupler, Quick, Ag, Male, 1/2"

AR - As Required NSS - Not Serviced Separately ASN - After Serial No. BSN - Before Serial No. LP - Local Purchase

PARTS ILLUSTRATIONS

Figure 3-10. Decals



1



2



3



4

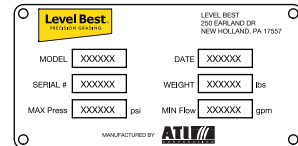

5

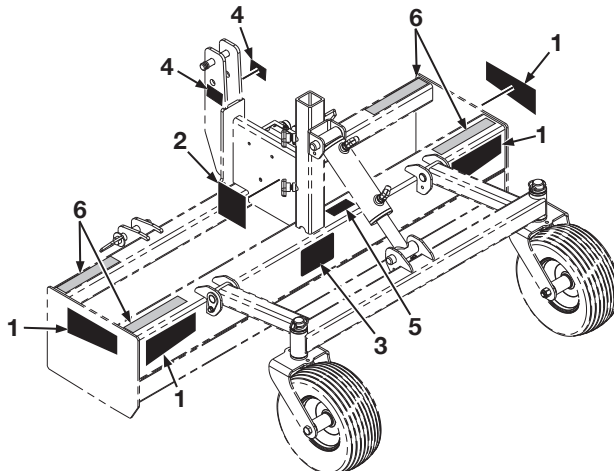

PARTS ILLUSTRATIONS

Figure 3-10. Decals

Item	Part No.	Qty	Description
1	000-186-001	4	Decal, Level Best Logo
2	000-186-041	1	Decal, Warning, High-Pressure (Hydraulic Application Only)
3	000-186-094	1	Decal, Warning, This Machine Starts & Stops Automatically
4	000-186-092	2	Decal, Made in U.S.A.
5	000-186-111	1	Plate, Model/Serial
6	LP	AR	Skid Grip

AR - As Required NSS - Not Serviced Separately ASN - After Serial No. BSN - Before Serial No. LP - Local Purchase

(for future use)

INDEX

A		S	
Align Rotating Laser with Grade Stakes	1.6	Safety Information.....	v
B		Safety Precaution Definitions.....	v
Benching.....	1.7	SC Series Hydraulic Valve	1.9
Benching And Operating	1.7	Serial Number Information.....	3.2
Benching with a Rod Eye.....	1.7	Service	1.10
C		Set-Up for Level Grading.....	1.5
Calibration	1.10	Set-Up for Sloped Grading.....	1.5
Caster Fork and Wheel	3.8	Storage and Transport.....	1.10
Cleaning.....	1.10	Systems Features and Basic Operation.....	1.1
Components.....	1.3	T	
Control Panel, Receiver, Cables - Spectra.....	3.18	Table of Contents.....	iii
D		Troubleshooting.....	2.1
Decals	3.22	W	
Dimensions	1.9	Warranty	iv
Disclaimer.....	i	Wheel Frame and Related Parts	3.6
Drawbar, with Wheel Locks.....	3.20	Where To Get Parts and Service.....	3.2
H			
How To Order Parts.....	3.2		
Hydraulic Valve Assembly	3.14		
Hydraulic Valve Assembly, Cylinder Assembly and Related Parts.....	3.10		
Hydraulic With Optional Valve Assembly.....	3.12		
I			
Index.....	4.1		
J			
Job Site Set-Up.....	1.4		
L			
Laser Controls and Related Parts - Spectra	3.16		
M			
Main Frame and Cutting Edges.....	3.4		
Maintenance	1.10		
N			
Notes.....	ii		
P			
Parts Illustrations	3.1		
Purpose	1.3		
R			
Rotating Laser	1.4		

(for future use)

