

OPERATORS & PARTS MANUAL

PD - SERIES BOX BLADE

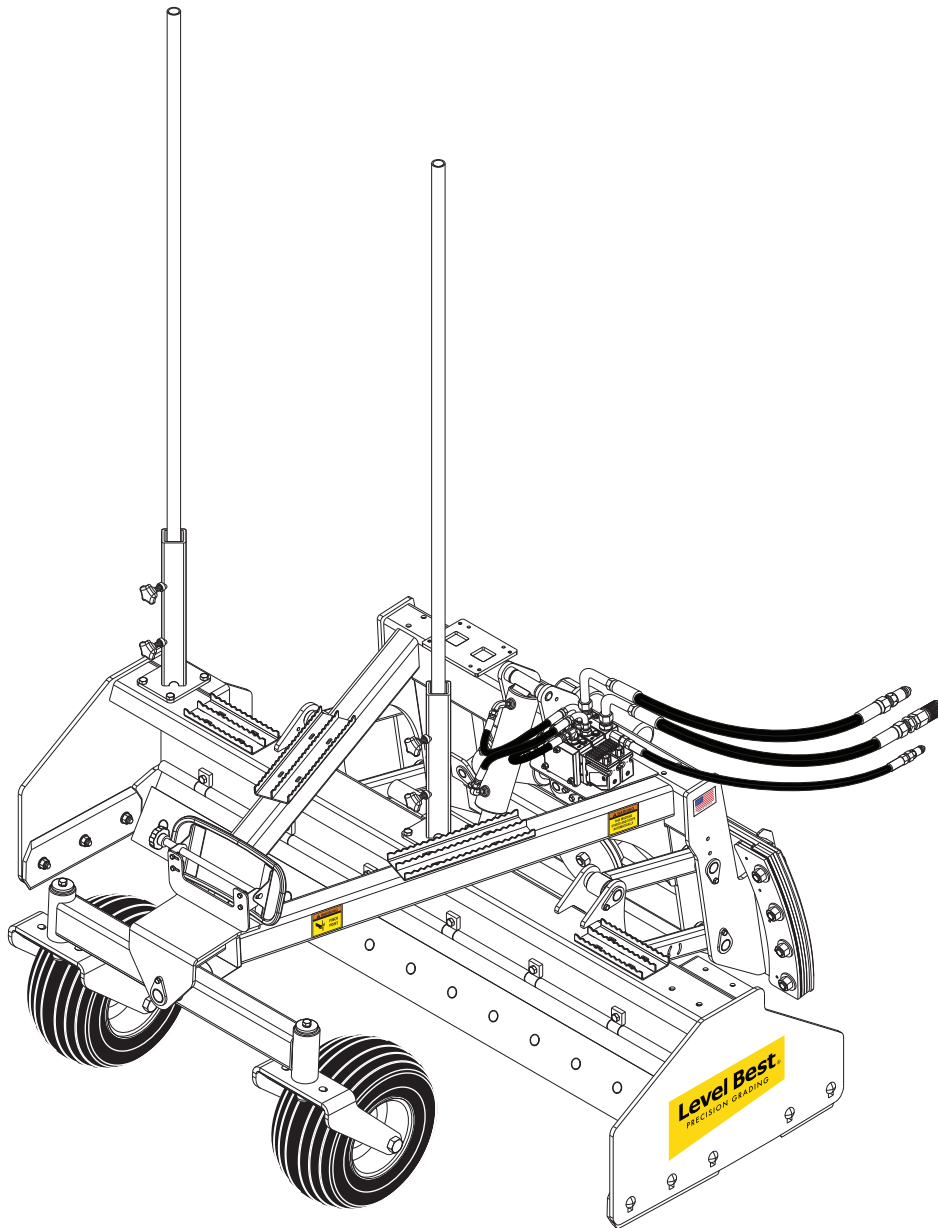

ATI Group, LLC
New Holland, PA 17557
1-800-342-0905
www.LevelBestGrading.com

ASN 3516

SEPTEMBER 2024
CAT.# PD-O&PM 09/01/24

COPYRIGHT 2024 by
ATI Group, LLC
250 Earland Drive
New Holland, PA 17557 U.S.A.

DISCLAIMER

THE INFORMATION IN THIS MANUAL IS PROVIDED TO PROMOTE THE SAFE USE OF, AND ASSIST THE OPERATOR IN ACHIEVING THE BEST PERFORMANCE FROM, PARA-LEVEL GRADING BOX DESCRIBED HEREIN, FOR THEIR INTENDED APPLICATIONS.

USING THIS DOCUMENT

This document is expected to be used as an electronic pdf document as well as a printed document. Various software can be used to view the document, including [Adobe® Acrobat Reader DC](#). Other pdf viewers are available.

As an electronic document, various links are included to help you navigate the document and find the applicable information. Links may be cross references within the document or an external link to an Internet page. Links shown in blue, such as the link to the Acrobat Reader DC software in the preceding paragraph. For an Internet link to work, the device must be connected to the Internet in some way. Data charges may apply.

NOTE: Most pdf viewer software provides a command for previous view. In Acrobat Reader, for instance, the previous view on the View/Page Navigation menu. Keyboard shortcuts are also available, such as Alt+Left Arrow and Alt+Right Arrow for Previous View and Next View, respectively.

TABLE OF CONTENTS

Disclaimer.....	i
Using This Document.....	i
Notes.....	ii
Table of Contents.....	iii
List of Illustrations.....	iv
Warranty.....	vi
Safety Information.....	vii
Systems Features And Basic Operation.....	1.1
Joystick Controls.....	2.1
Topcon 3DMC.....	3.1
Topcon System 5.....	4.1
Trimble Earthworks GO.....	5.1
Specifications and Maintenance.....	6.1
Troubleshooting.....	7.1
Parts Illustrations.....	8.1
Serial Number Information.....	8.2
Where To Get Parts And Service.....	8.2
How To Order Parts.....	8.2
List of Parts Illustrations.....	8.3
Index.....	9.1

LIST OF ILLUSTRATIONS

Figure 1-1.	Connector 14 - Socket.....	1.1
Figure 1-2.	Joystick Functions.....	1.1
Figure 2-1.	Cat D-Series Joystick Functions.....	2.1
Figure 2-2.	Bobcat Joystick Functions.....	2.1
Figure 2-3.	John Deere E-Series Joystick Functions.....	2.2
Figure 2-4.	John Deere G-Series Joystick Functions.....	2.2
Figure 2-5.	Kubota SSV65 & 75 Joystick Functions.....	2.3
Figure 2-6.	Kubota SVL 95 S6699 Multifunction Controller Kit.....	2.3
Figure 2-7.	CNH Joystick Functions B-Series.....	2.4
Figure 2-8.	CNH Joystick Functions 550-Series.....	2.4
Figure 2-9.	Case Joystick Functions.....	2.5
Figure 2-10.	New Holland Joystick Functions.....	2.5
Figure 2-11.	Takeuchi TL12/TL250 Joystick Functions.....	2.6
Figure 2-12.	JCB/Volvo Joystick Functions.....	2.6
Figure 2-13.	Mustang/Gehl Joystick Functions.....	2.7
Figure 3-1.	General Arrangement for Integrated Machine Harness.....	3.2
Figure 3-2.	General Arrangement Universal Joystick.....	3.4
Figure 3-3.	Module Controller.....	3.6
Figure 3-4.	Valve Module Cable.....	3.6
Figure 3-5.	Level Best Joystick Harness.....	3.7
Figure 3-6.	Joystick with Cable.....	3.7
Figure 4-1.	General Arrangement for Integrated Machine Harness.....	4.2
Figure 4-2.	General Arrangement Universal Joystick.....	4.4
Figure 4-3.	Module Controller.....	4.6
Figure 4-4.	Valve Module Cable.....	4.6
Figure 4-5.	Level Best Joystick Harness.....	4.7
Figure 4-6.	Joystick with Cable.....	4.7
Figure 5-1.	General Arrangement for Earthworks GO.....	5.2
Figure 5-2.	Earthworks GO Laser Receiver, Cables and Box.....	5.3
Figure 6-1.	Shims and Slide Pads.....	6.2
Figure 6-2.	Lube and Maintenance.....	6.3
Figure 6-3.	Hydraulic Valve.....	6.4
Figure 6-4.	Hydraulic Hose Connections to Skid Steer.....	6.4
Figure 6-5.	Vacuum Cup.....	6.5
Figure 8-1.	Main Frame and Cutting Edges.....	8.4
Figure 8-2.	Attachment Frame and Related Parts.....	8.6
Figure 8-3.	Caster Fork and Wheel.....	8.8

LIST OF ILLUSTRATIONS

Figure 8-4.	Hydraulics & Related Parts	8.10
Figure 8-5.	Hydraulic Valve Assembly	8.12
Figure 8-6.	Hydraulics Slope Cylinder, Fittings and Related Parts	8.14
Figure 8-7.	Slope Frame, Shims and Related Parts.....	8.16
Figure 8-8.	Laser Controls and Related Parts - Trimble Earthworks Go!.....	8.18
Figure 8-9.	Box, Laser Receiver 360°, Cables - Trimble Earthworks Go!	8.20
Figure 8-10.	Decals	8.22

WARRANTY

General Provisions. The warranties described below are provided by ATI Group LLC (“ATI”) to the original purchaser of new Level Best grading equipment (“Equipment”) from an authorized Level Best dealer. Under these warranties, ATI will repair or replace, at its option, any covered part which is found to be defective in material or workmanship during the applicable warranty term. Warranty service must be performed by a dealer or service center authorized by ATI to sell and/or service the type of Equipment involved, which will use only new or remanufactured parts or components furnished by ATI. Warranty service will be performed without charge to the purchaser for parts or labor. The purchaser will be responsible, however, for any service call and/or transportation of product to and from the dealer’s or service center’s place of business, for any premium charged for overtime labor requested by the purchaser, and for any service and/or maintenance not directly related to any defect covered under the warranties below.

What Is Warranted. All parts of any new Level Best grading equipment are warranted for 36 months except for the following: (1) wear parts, and (2) third-party machine guidance systems (which are warranted under their respective manufacturer’s warranty). The warranty term for all coverage begins at the time that any person, dealer, or agent first places a unit into service. At the latest, a unit is considered placed into service when delivered to an initial retail purchaser.

What Is Not Warranted. ATI is not responsible for the following:

- (1) Used Equipment;
- (2) Any Equipment that has been altered or modified in ways not approved by ATI;
- (3) Depreciation or damage caused by normal wear, lack of reasonable and proper maintenance, failure to follow operating instructions, misuse, lack of proper protection during storage, or accident;
- (4) Normal maintenance parts and service;
- (5) Economic loss including lost profit, equipment rental, or other expenses.

Securing Warranty Service. To secure warranty service, the purchaser must (1) Report the product defect to an authorized dealer and request repair within the applicable warranty term, (2) Present evidence of the warranty start date, and (3) Make the equipment available to an authorized dealer or service center within a reasonable time.

Limitation Of Implied Warranties and Other Remedies. To the extent permitted by law, neither ATI nor any company affiliated with it makes any warranties, representations or promises as to the quality, performance or freedom from defect of the Level Best Equipment covered by this warranty. IMPLIED WARRANTIES OF MERCHANTABILITY AND FITNESS FOR A PARTICULAR PURPOSE, TO THE EXTENT APPLICABLE, SHALL BE LIMITED IN DURATION TO THE APPLICABLE PERIOD OF WARRANTY SET FORTH ON THIS PAGE. THE PURCHASER’S ONLY REMEDIES IN CONNECTION WITH THE BREACH OR PERFORMANCE OF ANY WARRANTY ON THE LEVEL BEST EQUIPMENT ARE THOSE SET FORTH ON THIS PAGE. IN NO EVENT WILL THE DEALER, ATI, OR ANY COMPANY AFFILIATED WITH ATI, BE LIABLE FOR INCIDENTAL OR CONSEQUENTIAL DAMAGES.

No Dealer Warranty. The selling dealer makes no warranty of its own and the dealer has no authority to make any representation or promise on behalf of ATI, or to modify the terms or limitations of this warranty in any way.

SAFETY INFORMATION

This manual is furnished to you, the owner/operator, as a guide to get the greatest benefit from your grading box. ATI Group, LLC wants you to be able to get the most use out of your grading box through safe and efficient operation.

Before attempting to operate the grading box, carefully read all sections of this manual. Be sure that you thoroughly understand all of the safety information and operating procedures.

SAFETY PRECAUTION DEFINITIONS

Dangers, Warnings, Cautions, and Notes are strategically placed throughout this manual to further emphasize the importance of personal safety, qualifications of operating personnel, and proper use of the grading box in its intended application. These precautions supplement and/or complement the safety information decals affixed to the unit and include headings that are defined as follows:

DANGER

Indicates an imminently hazardous situation which, if not avoided, will result in death or serious injury.

WARNING

Indicates a potentially hazardous situation or practice which, if not avoided, could result in death or serious injury.

CAUTION

Indicates a potentially hazardous situation or practice which, if not avoided, will result in damage to equipment and/or minor injury.

NOTE: Indicates an operating procedure, practice, etc., or portion thereof, which is essential to highlight.

- Always use caution and safe operating practices when operating this equipment.
- Always set the Automatic/Manual Switch on the Control Panel to MANUAL before leaving the operator's seat or whenever the machine is not moving.

- Always allow for clearance under the cutting edge of the machine when tuning the system or when switching to automatic control. Insufficient clearance could cause the machine to lift itself off the ground as its cutting edge attempts to achieve the programmed slope.
- Never adjust the position of the laser receiver when the system is in automatic control.
- Never perform service work on your machine or the Automatic Control System when the system is in automatic control.
- Install all safety panels and guards before operating your equipment.
- Stay clear of all moving parts when the machine is in operation.
- Keep all people clear of the machine when it is running.
- Keep feet and other body parts from under the cutting edges of the machine at all times.
- Read and comply with all safety recommendations of your tractor/skid steer manufacturer, as outlined in its operator and service manuals.

NOTE: References made to left, right, front, and rear are those directions viewed from behind the power unit and grading box.

NOTE: Some equipment depicted in illustrations may not reflect exact production model configurations.

NOTE: All safety, operating, and servicing information reflects current production models at the time of publication of this manual.

NOTE: ATI Group, LLC reserves the right to discontinue models at any time, change specifications, and improve design without notice and without incurring obligation on goods previously purchased and to discontinue supplying any part listed, when the demand does not warrant production.

(for future use)

SYSTEMS FEATURES AND BASIC OPERATION

OVERVIEW

The Level Best grading box is a cost-efficient method for fine grading. Various capacities sized to fit all sizes of skid steer loaders or compact track loaders (CTL) with a choice of automatic control systems are available.

A typical 2D system provides laser-guided depth control along a plane from a single reference point which must be set up for each job site. A 3D system adds locating ability to the control through either a satellite constellation (GPS) or local positioning system (LPS). The control system not only knows the desired depth on the plane, but the location of the machine on the job site and, in the case of a GPS system, even which job site you are currently on.

The desired blade depth is processed and automatically controls the grading box's hydraulics to maintain the elevation of the cutting edge based on the site plan.

OPERATION

Operation of the grading box and automatic control system is typically in automatic mode. Depending upon the type of CTL, manual override and fine tuning are available through an optional joystick control or buttons on the CTL in-cab controls.

For CTLs equipped with buttons on the in-cab joysticks, Level Best provides a brand specific loader harness. This 14-socket harness plugs into the auxiliary electrical connector on the loader boom and allows for manual control of the grading box as well as interfaces with the control system to switch *Auto/Manual* mode and correct grade offset (*Increment/Decrement*).

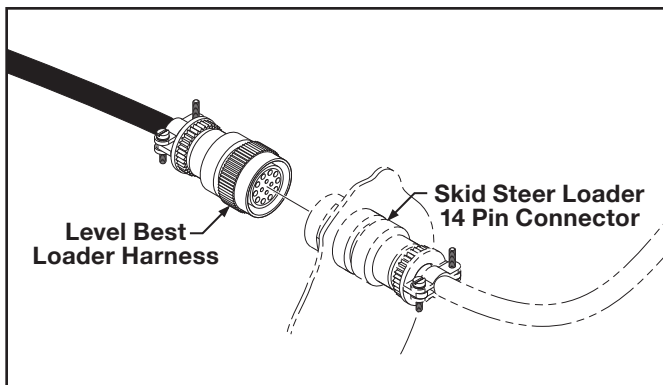

Figure 1-1. Connector 14 - Socket

See [Figure 2-1](#) through [Figure 2-13](#) starting on Page 2.1 for specific loader brand joystick layouts and corresponding Level Best functions.

For rental and mixed fleet applications or for loaders that do not have the required joystick configuration in the cab, Level Best provides an optional third joystick. This CAN joystick is mounting in the cab with a suction cup and provides full override capabilities of the grading box as well as interfaces with the control system to switch *Auto/Manual* mode and correct grade offset (*Increment/Decrement*).

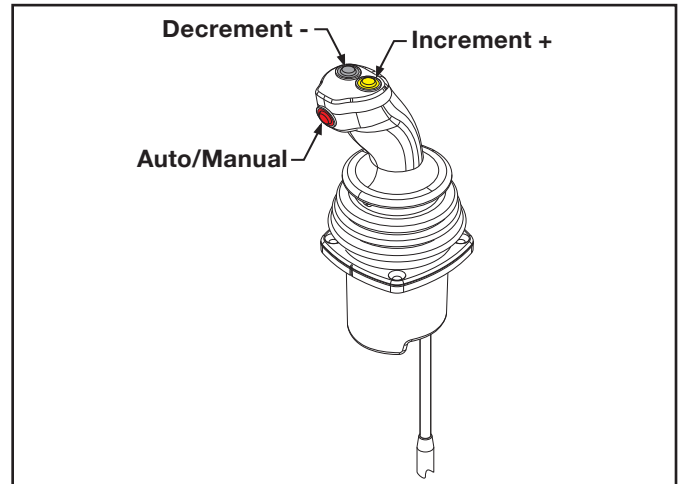

Figure 1-2. Joystick Functions

SYSTEMS FEATURES AND BASIC OPERATION

(for future use)

JOYSTICK CONTROLS

LOADER JOYSTICK FUNCTIONS

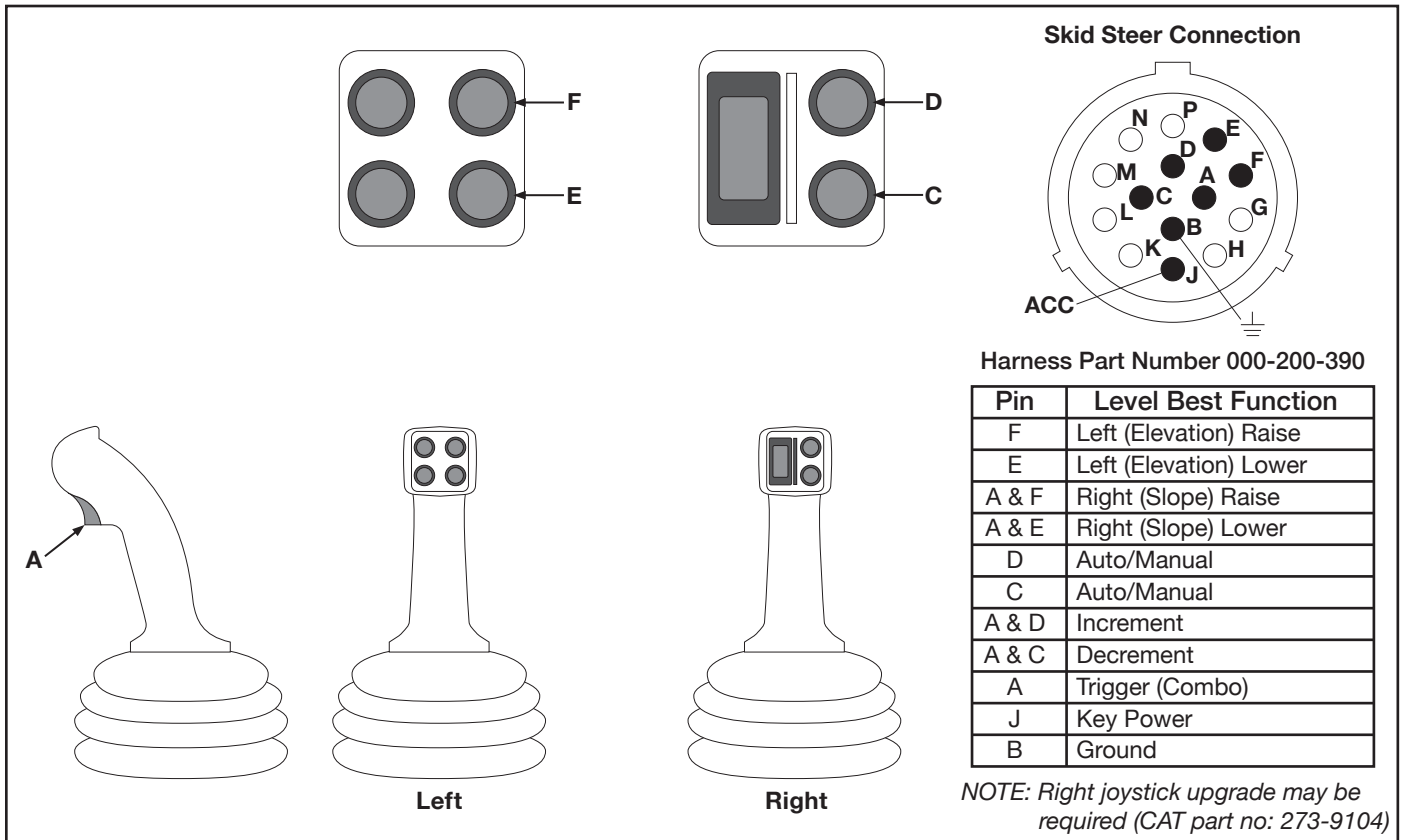

Figure 2-1. Cat D-Series Joystick Functions

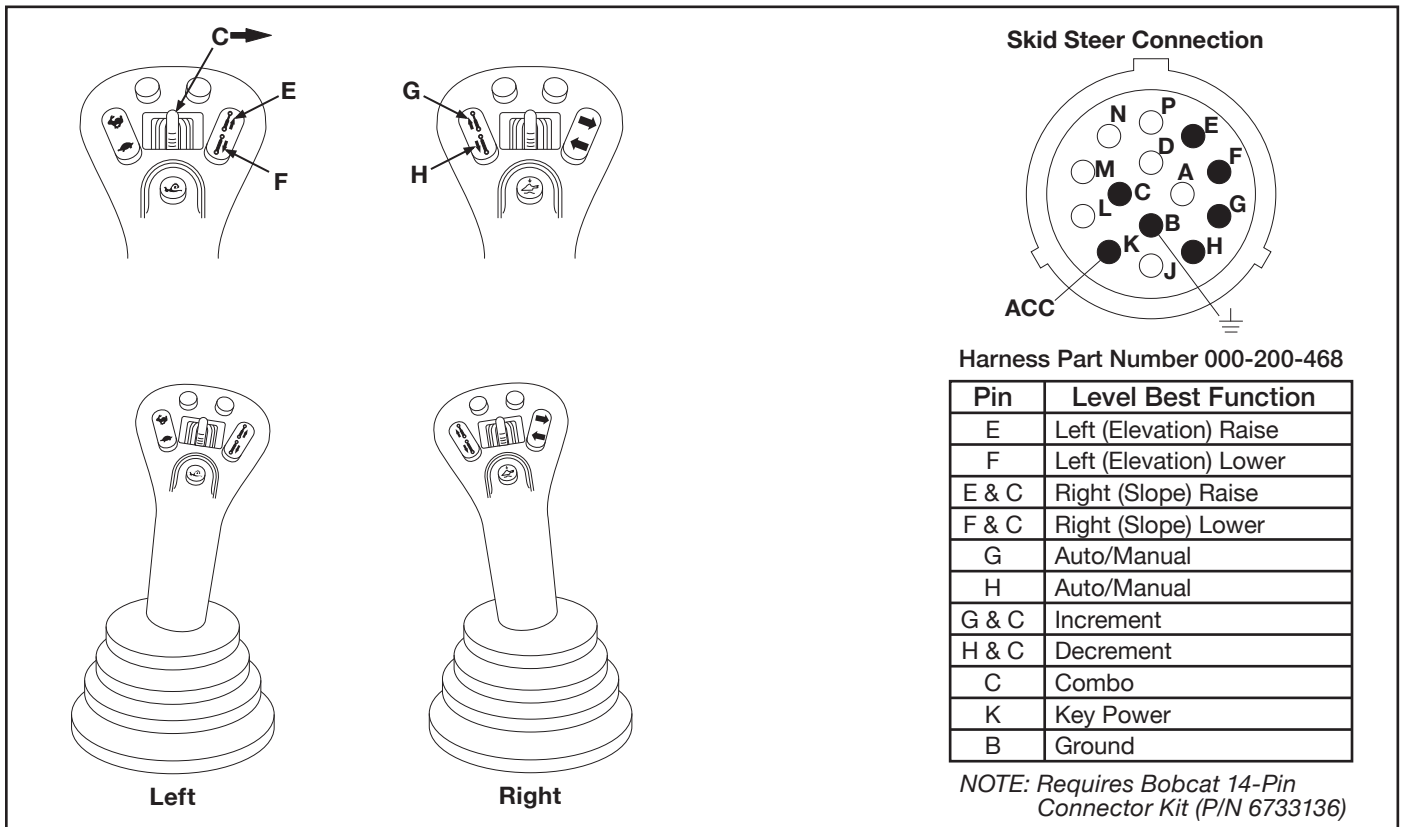

Figure 2-2. Bobcat Joystick Functions

JOYSTICK CONTROLS

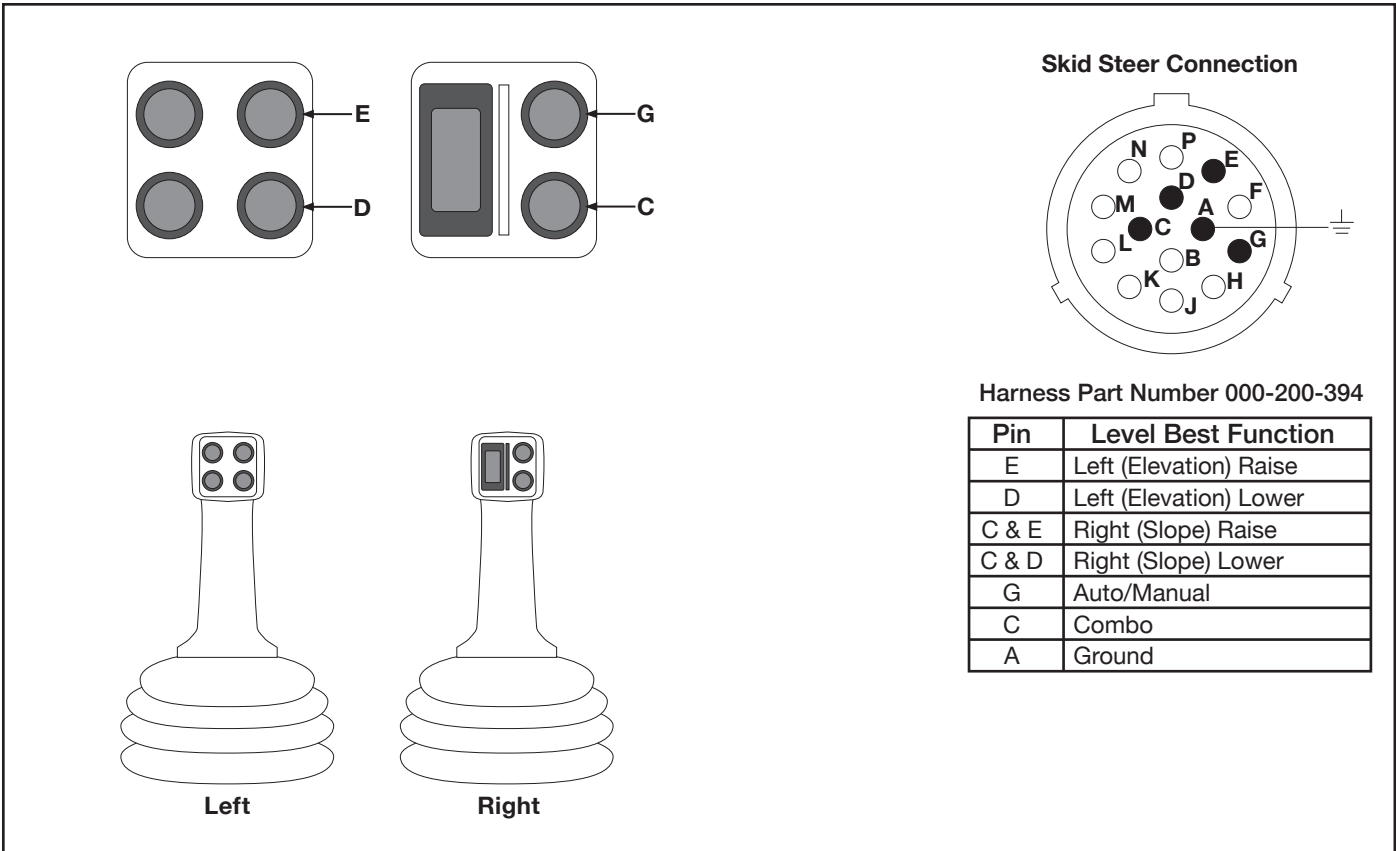

Figure 2-3. John Deere E-Series Joystick Functions

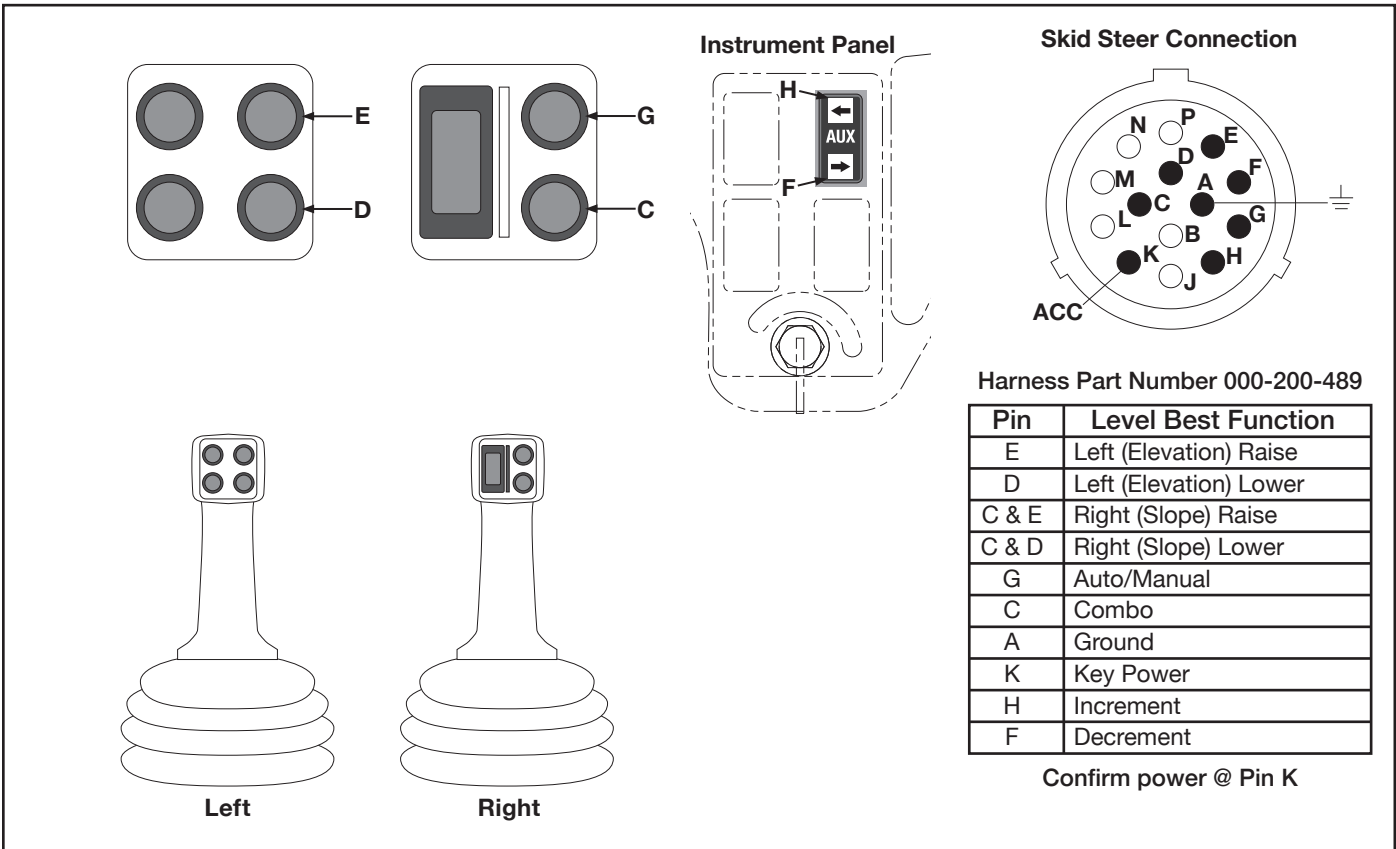

Figure 2-4. John Deere G-Series Joystick Functions

JOYSTICK CONTROLS

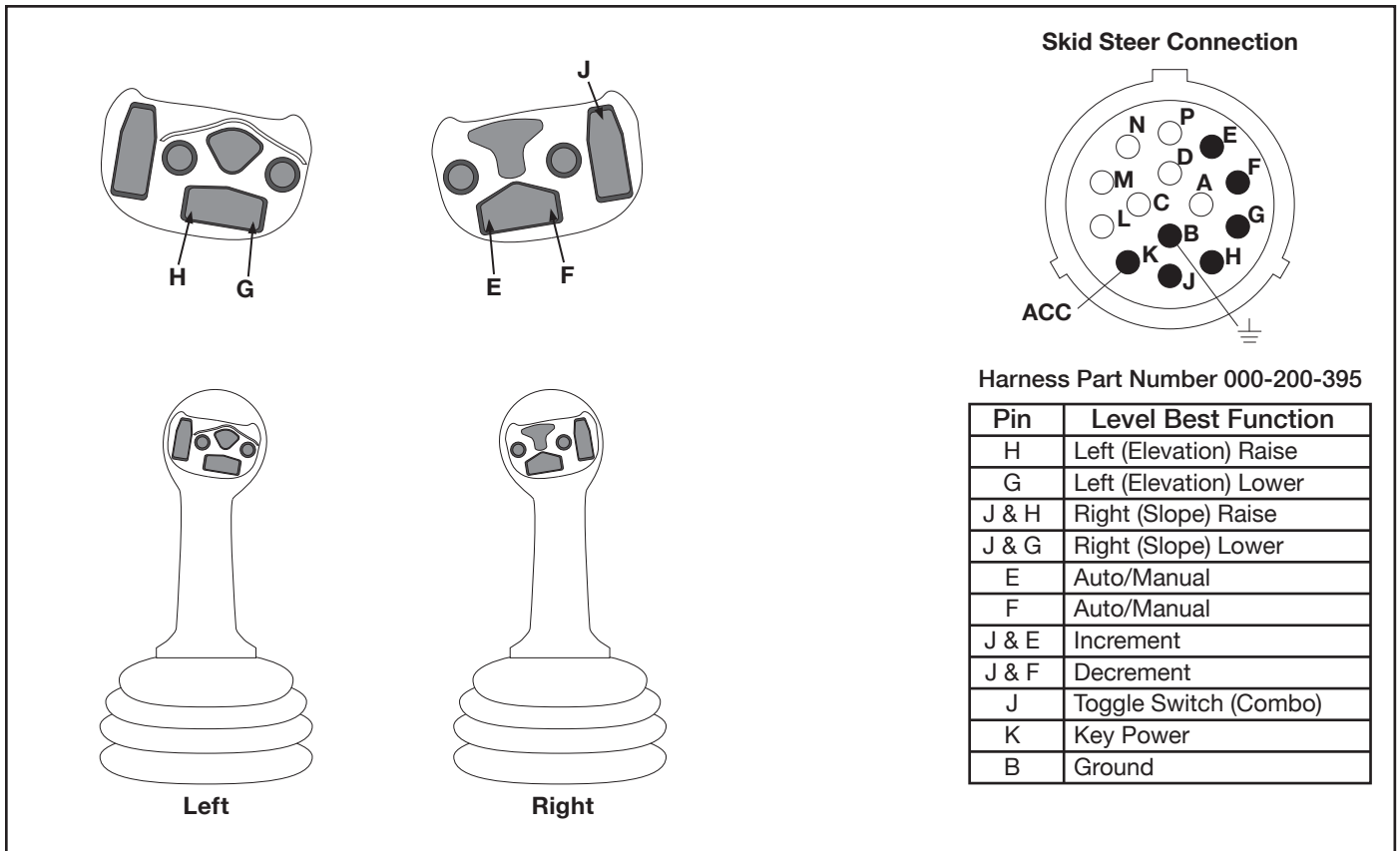

Figure 2-5. Kubota SSV65 & 75 Joystick Functions

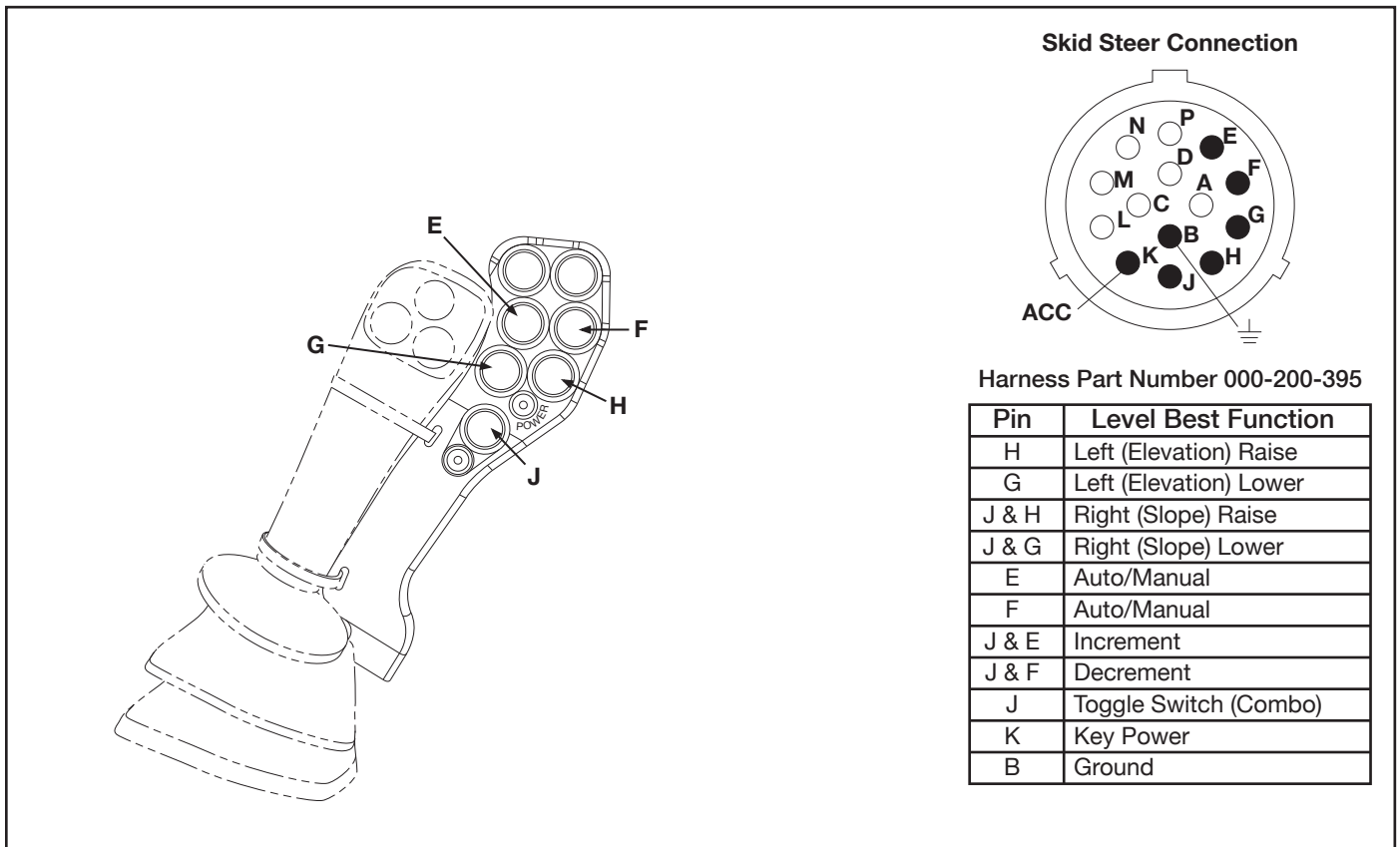

Figure 2-6. Kubota SVL 95 S6699 Multifunction Controller Kit

JOYSTICK CONTROLS

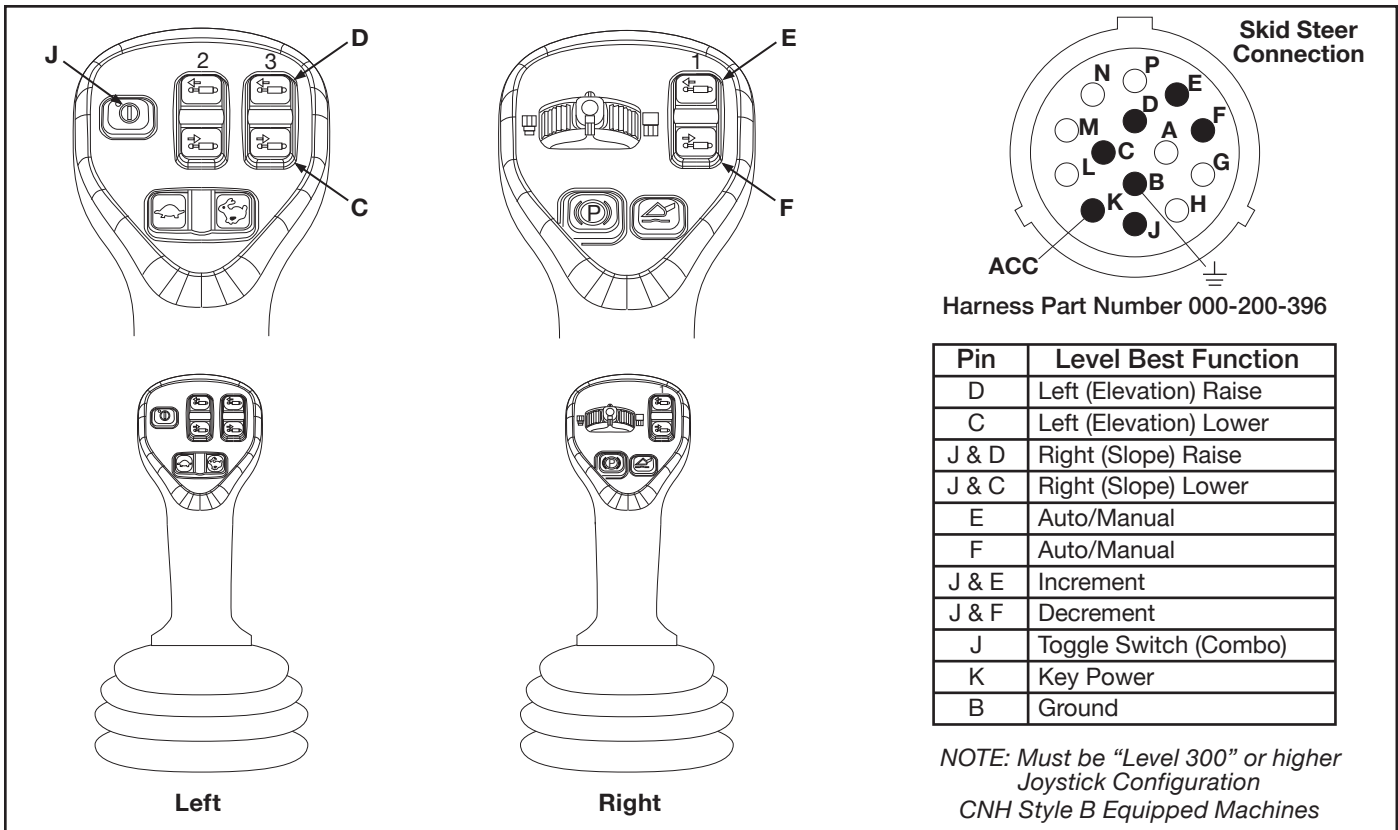

Figure 2-7. CNH Joystick Functions B-Series

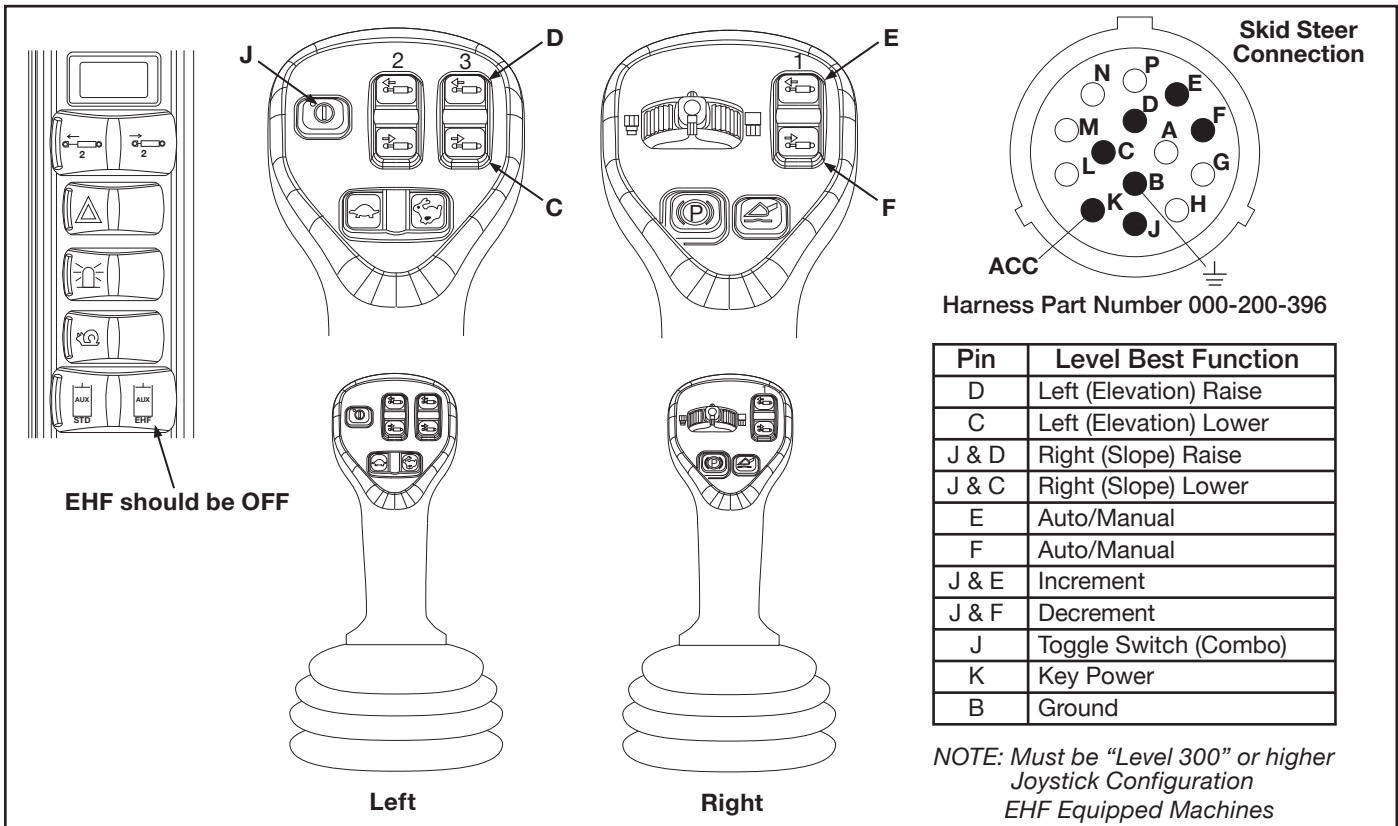

Figure 2-8. CNH Joystick Functions 550-Series

JOYSTICK CONTROLS

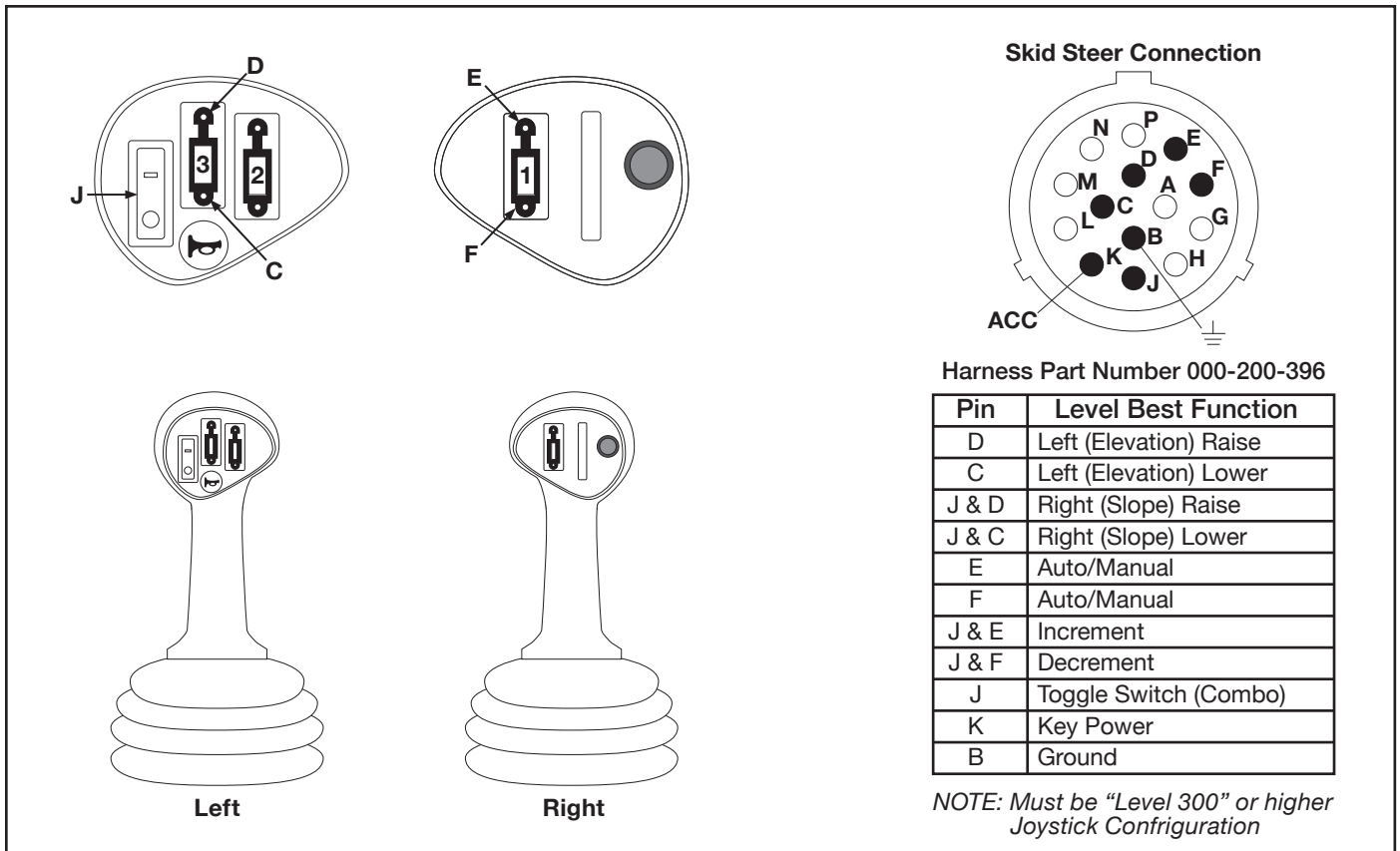

Figure 2-9. Case Joystick Functions

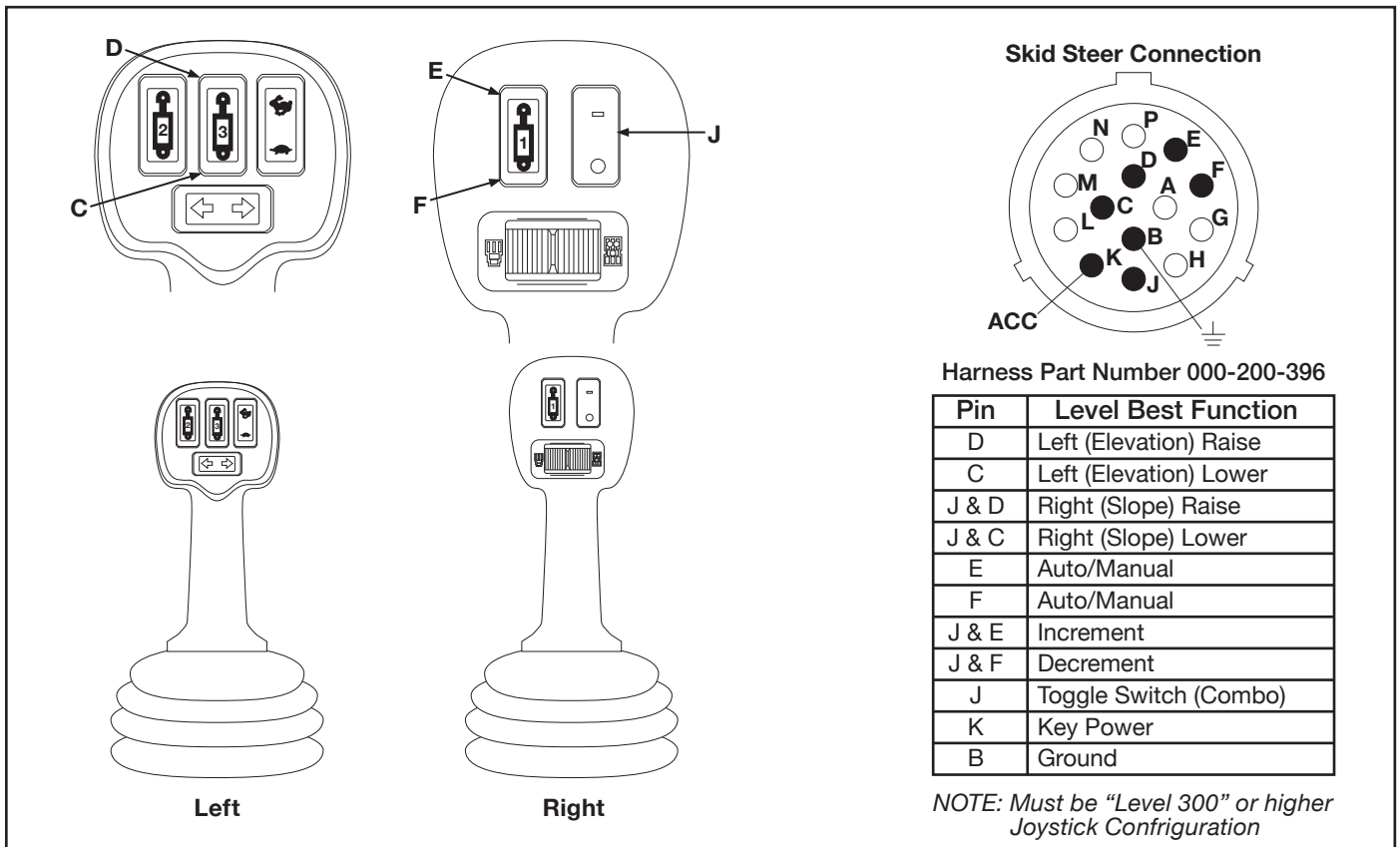

Figure 2-10. New Holland Joystick Functions

JOYSTICK CONTROLS

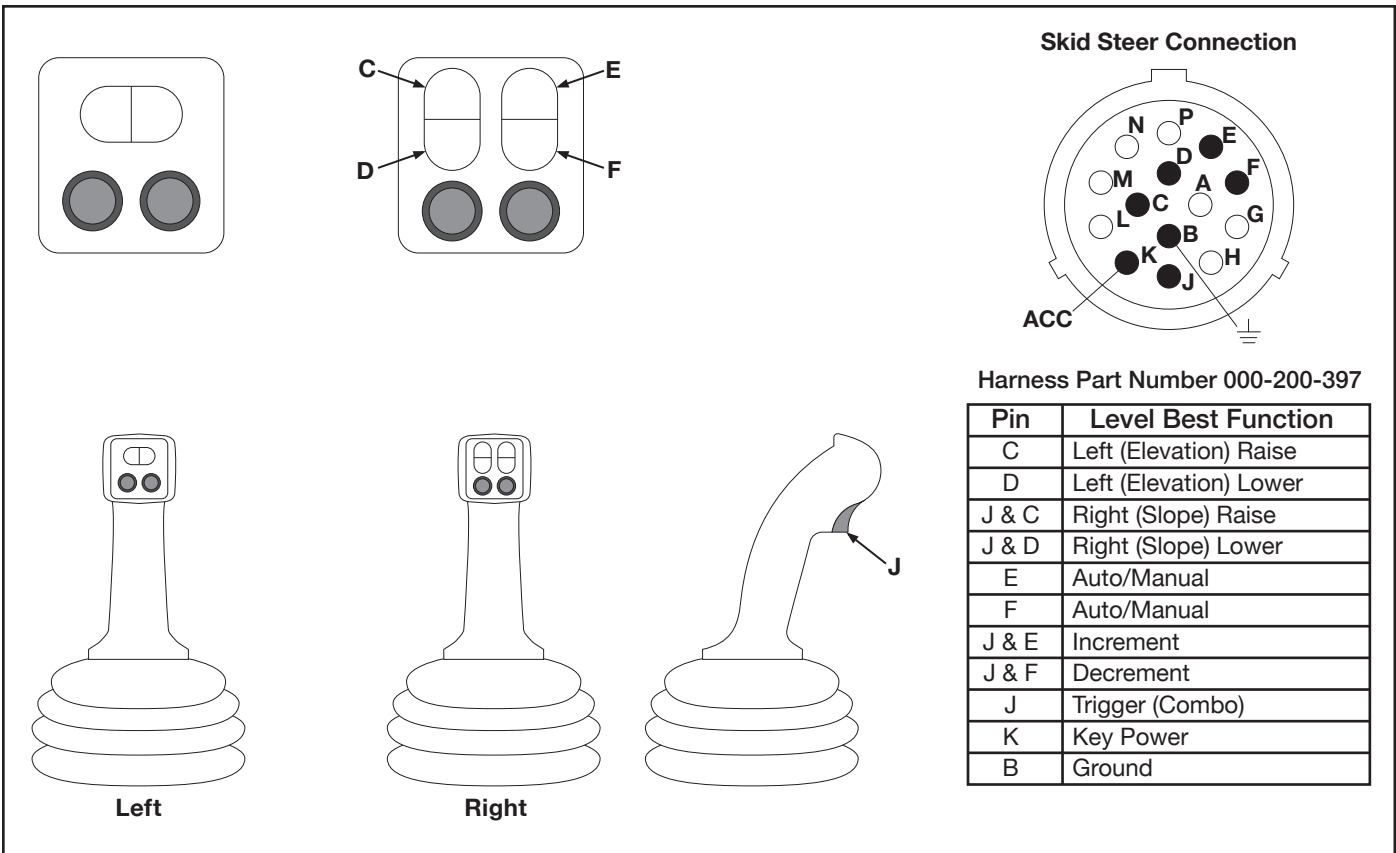

Figure 2-11. Takeuchi TL12/TL250 Joystick Functions

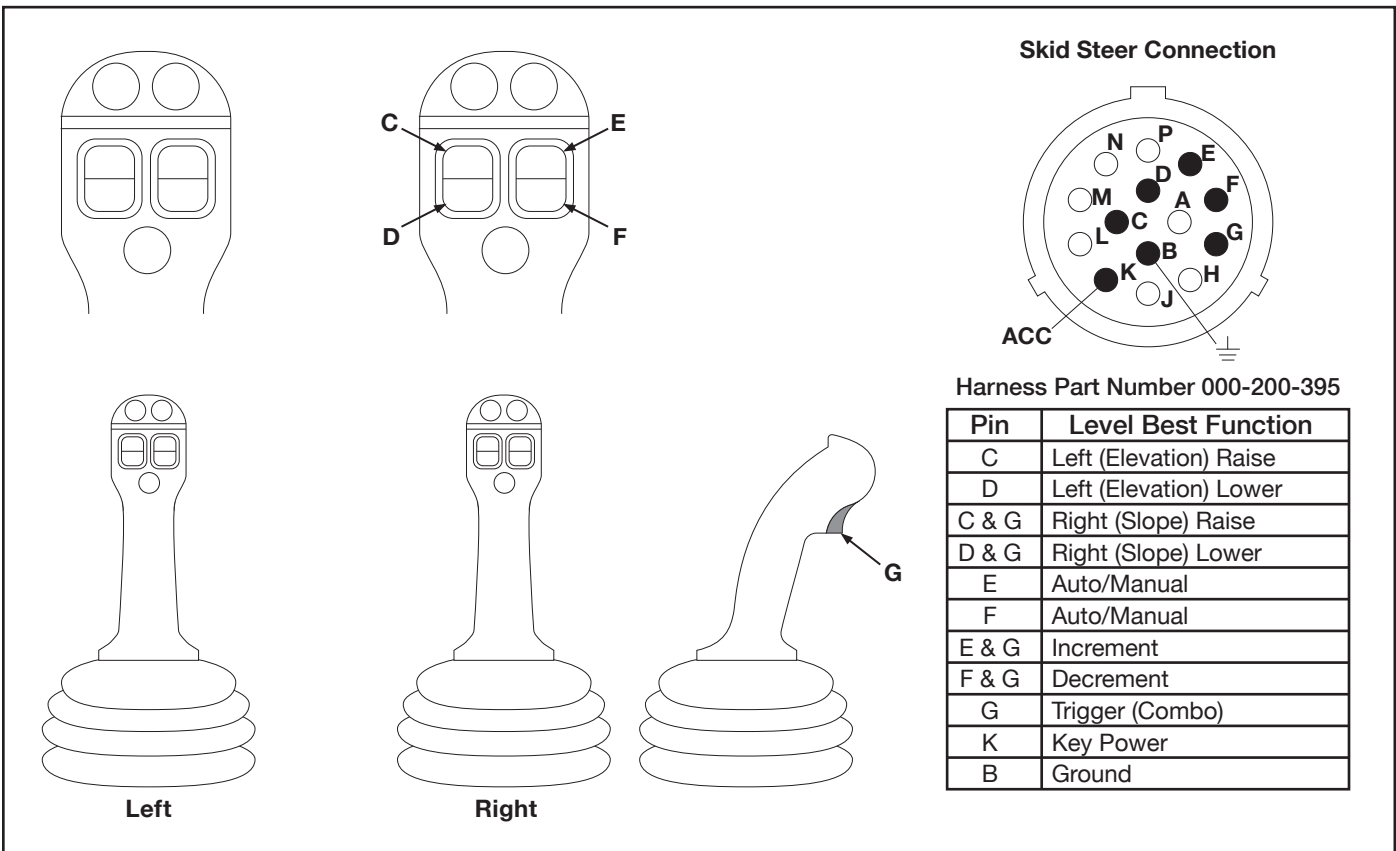

Figure 2-12. JCB/Volvo Joystick Functions

JOYSTICK CONTROLS

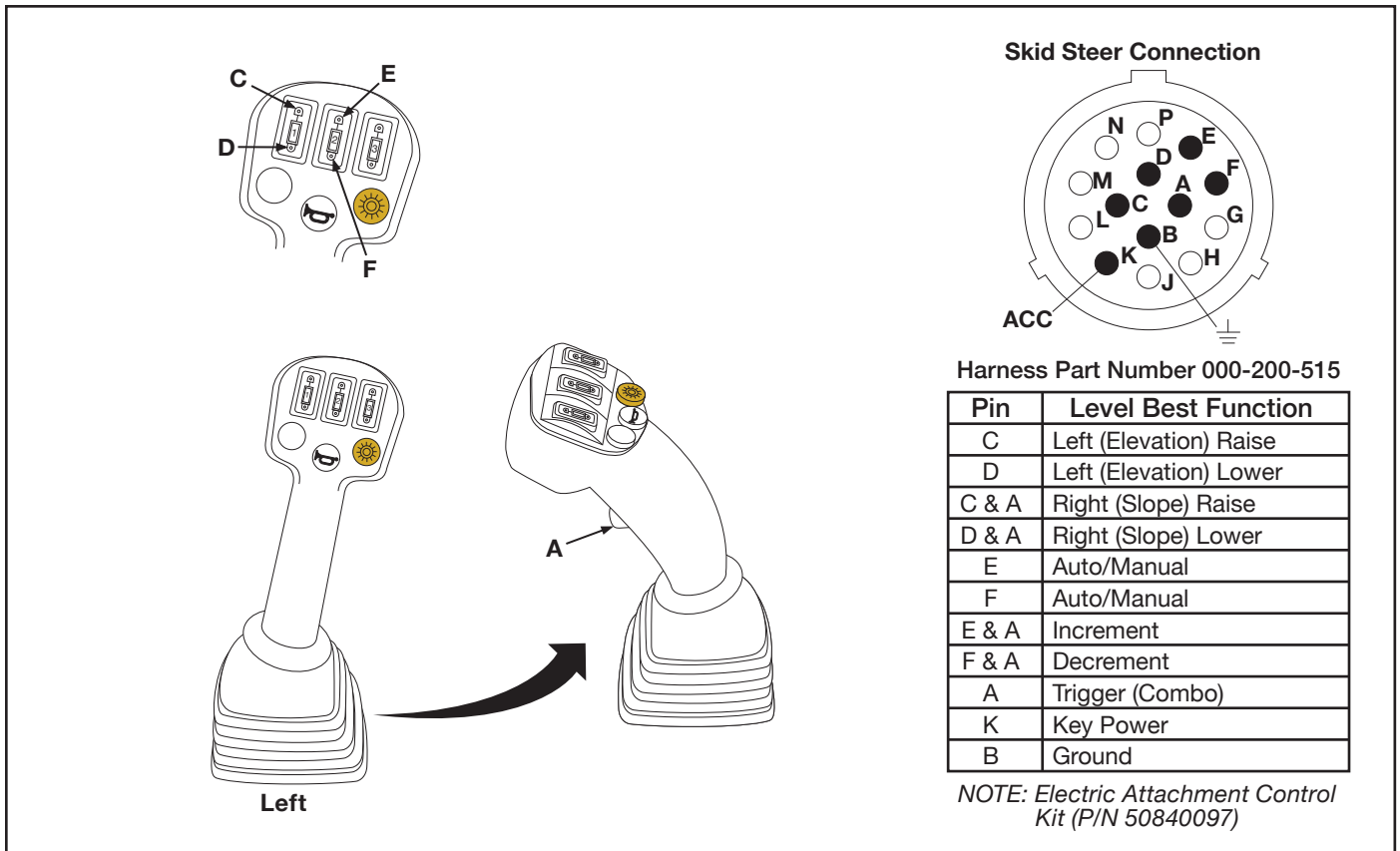

Figure 2-13. Mustang/Gehl Joystick Functions

NOTE: For any machine not listed, contact ATI for more information.

JOYSTICK CONTROLS

(for future use)

Figure 3-1. General Arrangement for Integrated Machine Harness..... 3.2

Figure 3-2. General Arrangement Universal Joystick..... 3.4

Figure 3-3. Module Controller 3.6

Figure 3-4. Valve Module Cable 3.6

Figure 3-5. Level Best Joystick Harness..... 3.7

Figure 3-6. Joystick with Cable 3.7

TOPCON 3DMC

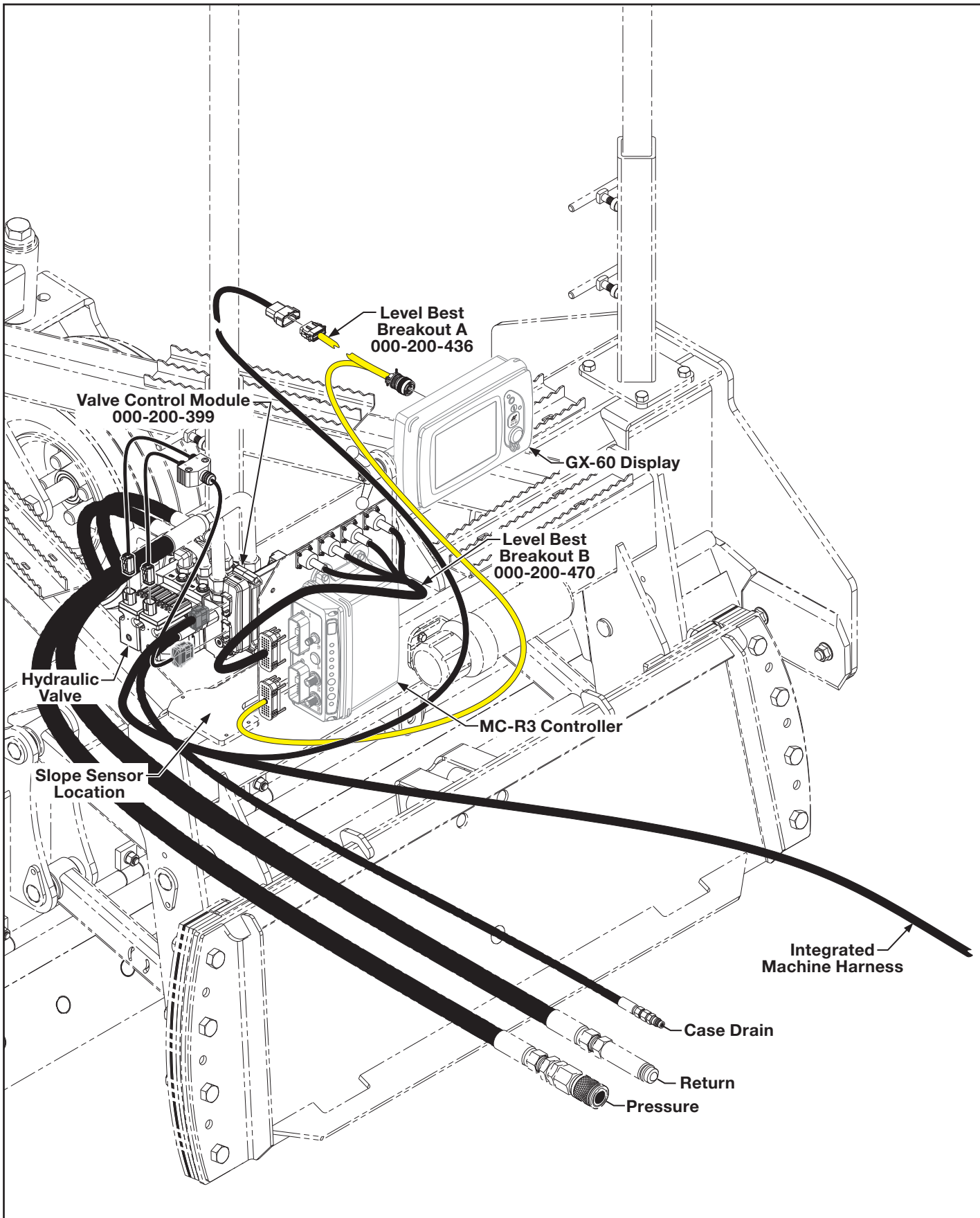

Figure 3-1. General Arrangement for Integrated Machine Harness

Topcon Configuration

NOTE: To ensure proper communication with the Level Best hydraulic control system, the Topcon Control Panel must be configured by an authorized Topcon representative.

To allow the Topcon Control Panel to properly address the Level Best hydraulic control valve, the following must be set:

The “Valve Input” must be set to *CNH CAN*.

The “Input Device” must be set to *CAN Input*.

NOTE: If required, run a wire from the loader’s back-up alarm to the ‘Back-up Alarm’ plug on the Breakout A harness. This needs to be a simple 12 V signal.

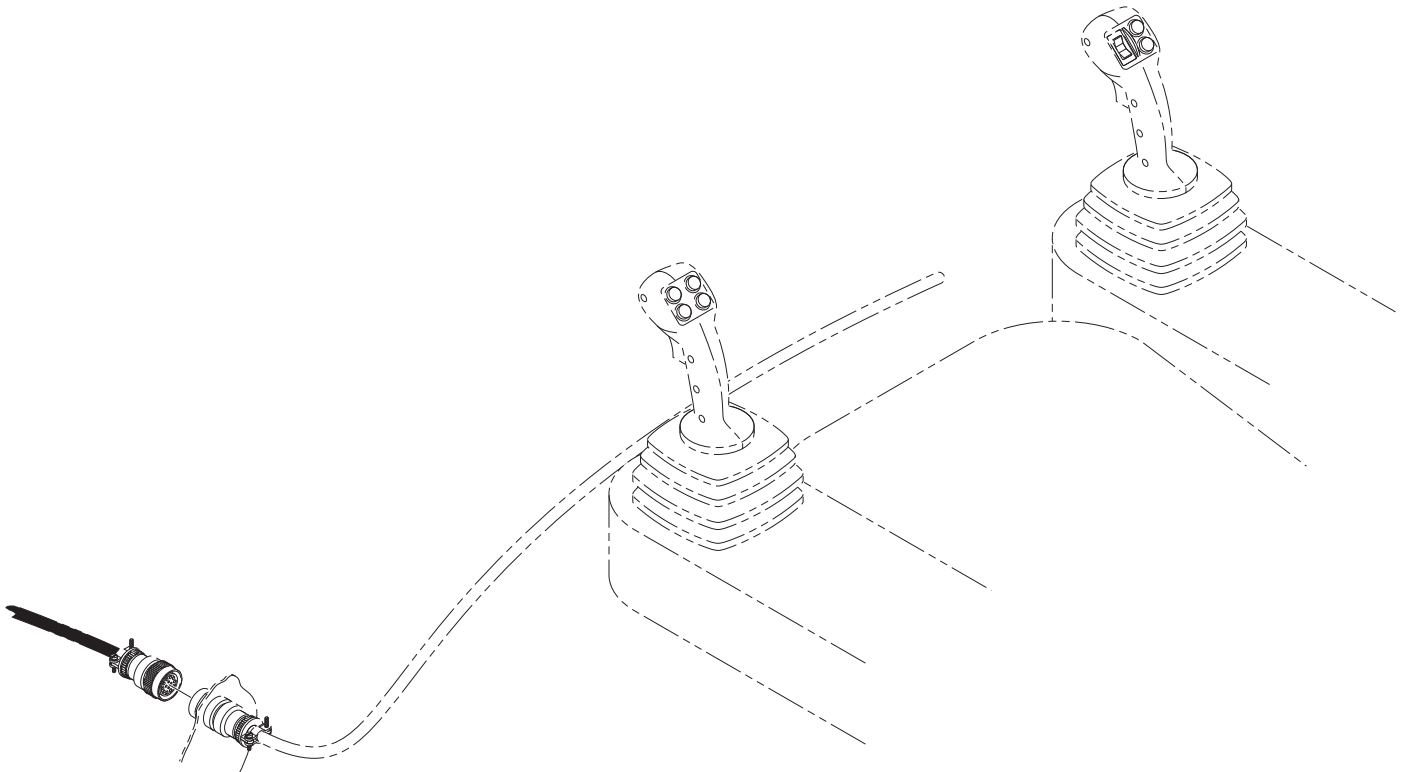
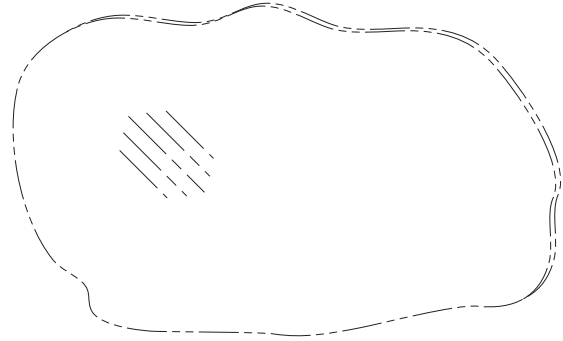

TOPCON 3DMC

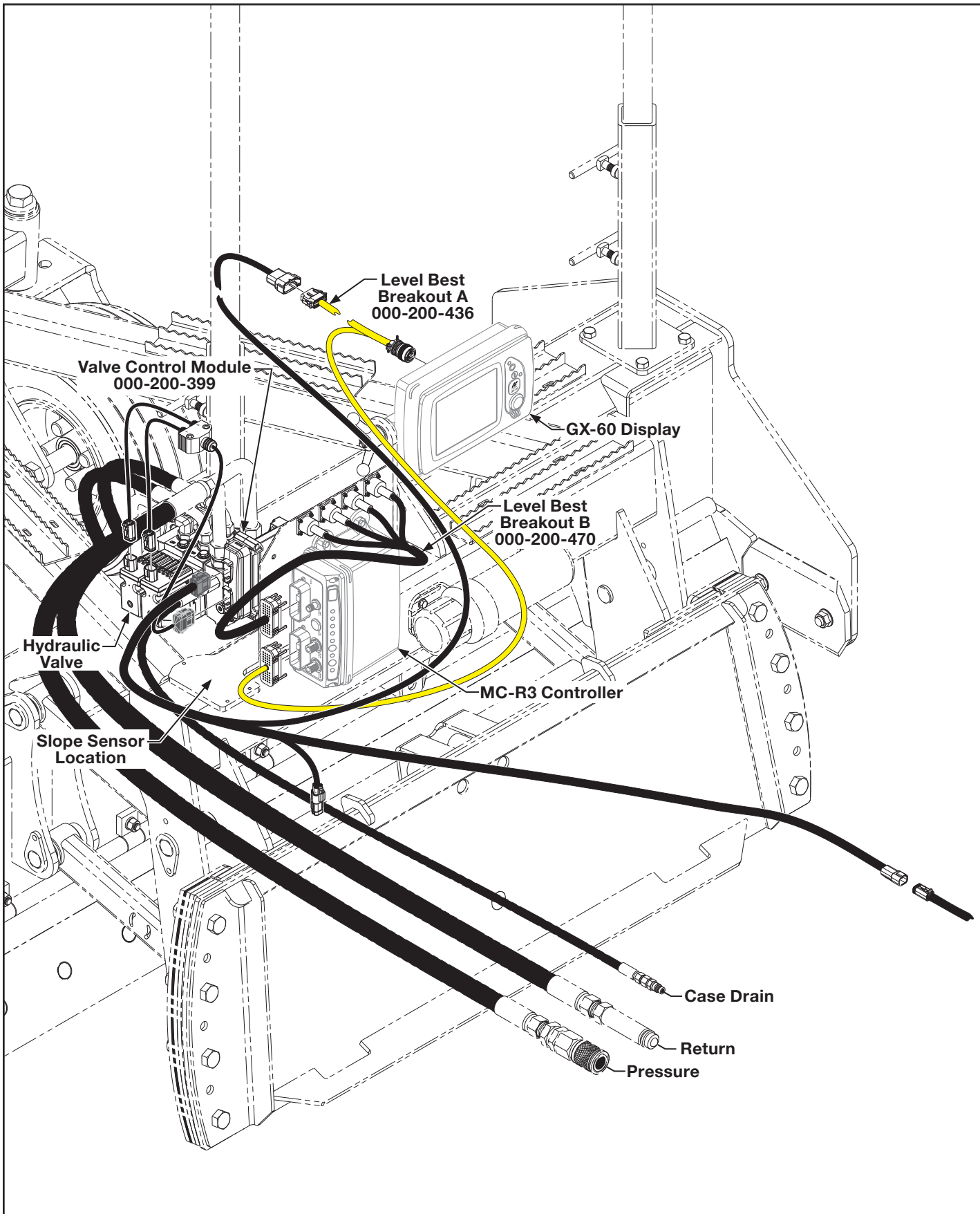

Figure 3-2. General Arrangement Universal Joystick

Topcon Configuration

NOTE: To ensure proper communication with the Level Best hydraulic control system, the Topcon Control Panel must be configured by an authorized Topcon representative.

To allow the Topcon Control Panel to properly address the Level Best hydraulic control valve, the following must be set:

The "Valve Input" must be set to *CNH CAN*.

The "Input Device" must be set to *CAN Input*.

NOTE: If required, run a wire from the loader's back-up alarm to the 'Back-up Alarm' plug on the Breakout A harness. This needs to be a simple 12 V signal.

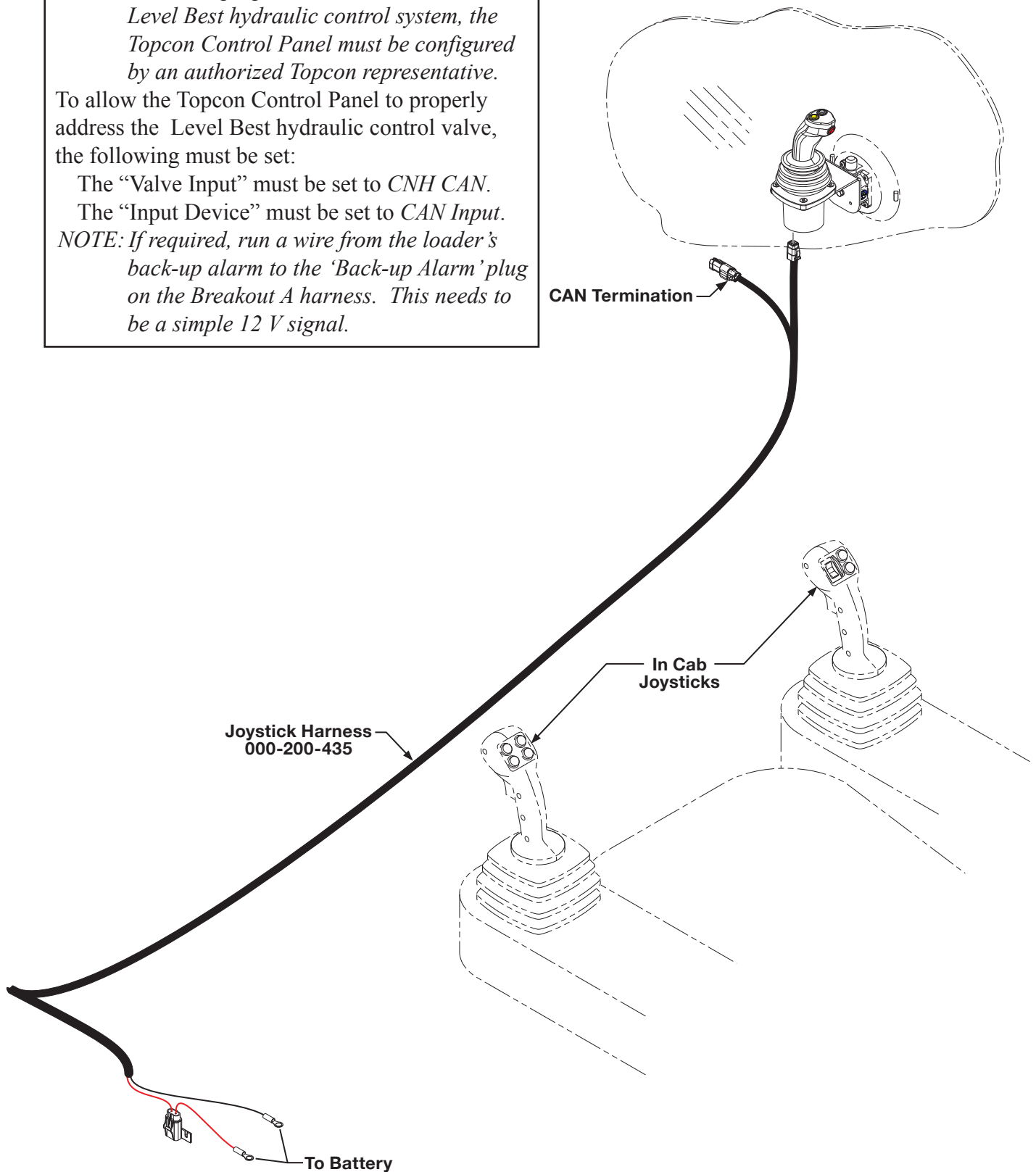

Connection of the Module Controller

The Module Controller provides the electronic interface between the Topcon control system in the cab and the hydraulic valve.

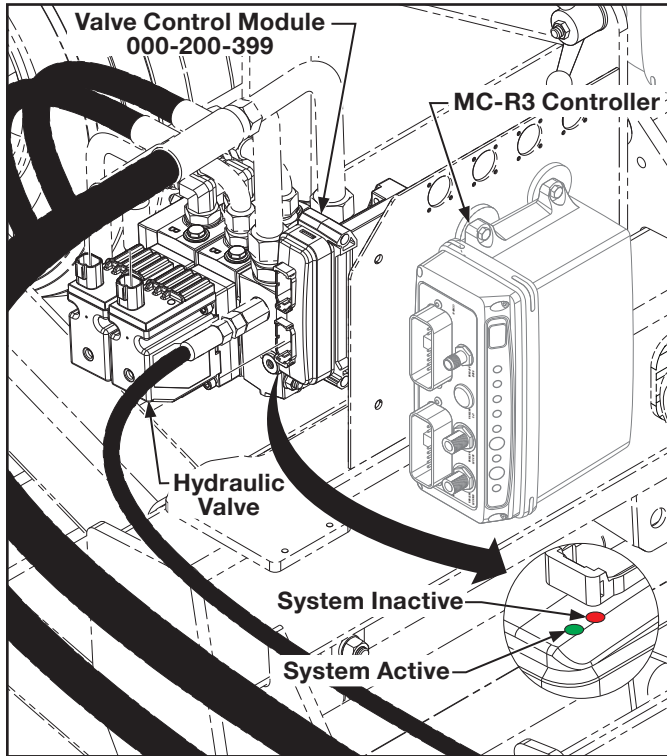

Figure 3-3. Module Controller

Connecting the two components is the Valve Module Cable (see [Figure 3-4](#)). Each connector to the valve is keyed to prevent insertion into the wrong socket. In the same way, the Module Controller end may only be inserted into the correct socket.

NOTE: Never force a plug into a socket. Plugs are keyed to prevent incorrect insertion.

Two LEDs indicate the operating status of the Module Controller.

The green LED indicates that power is applied and the system is operating normally.

The red LED indicates an error in the communications system. The wire connections should be checked and, if this does not solve the issue, contact your local Topcon service department.

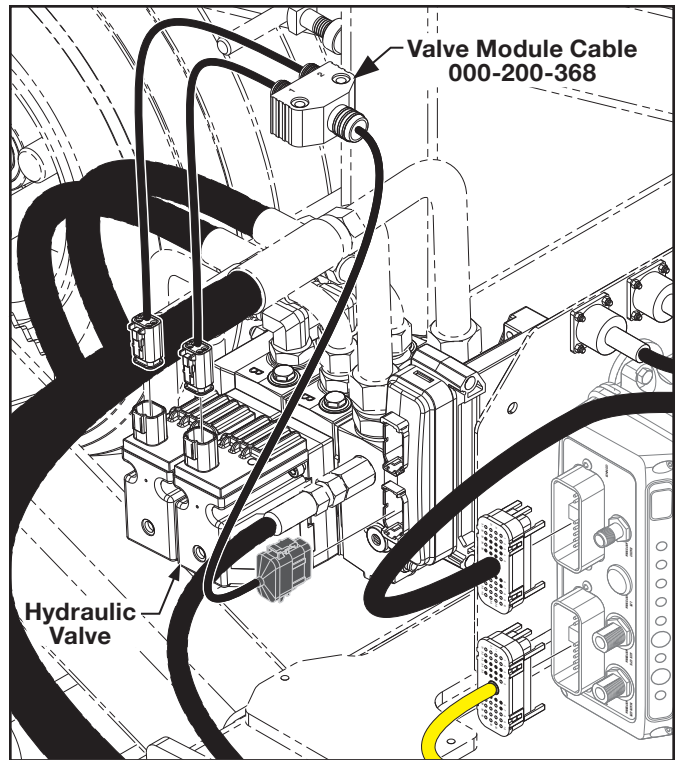

Figure 3-4. Valve Module Cable

The Module Controller also connects to the joystick cable (see [Figure 3-5](#)) note that this cable includes a connector to allow the grading box to be removed from the skid steer without fully removing the cable from the machine.

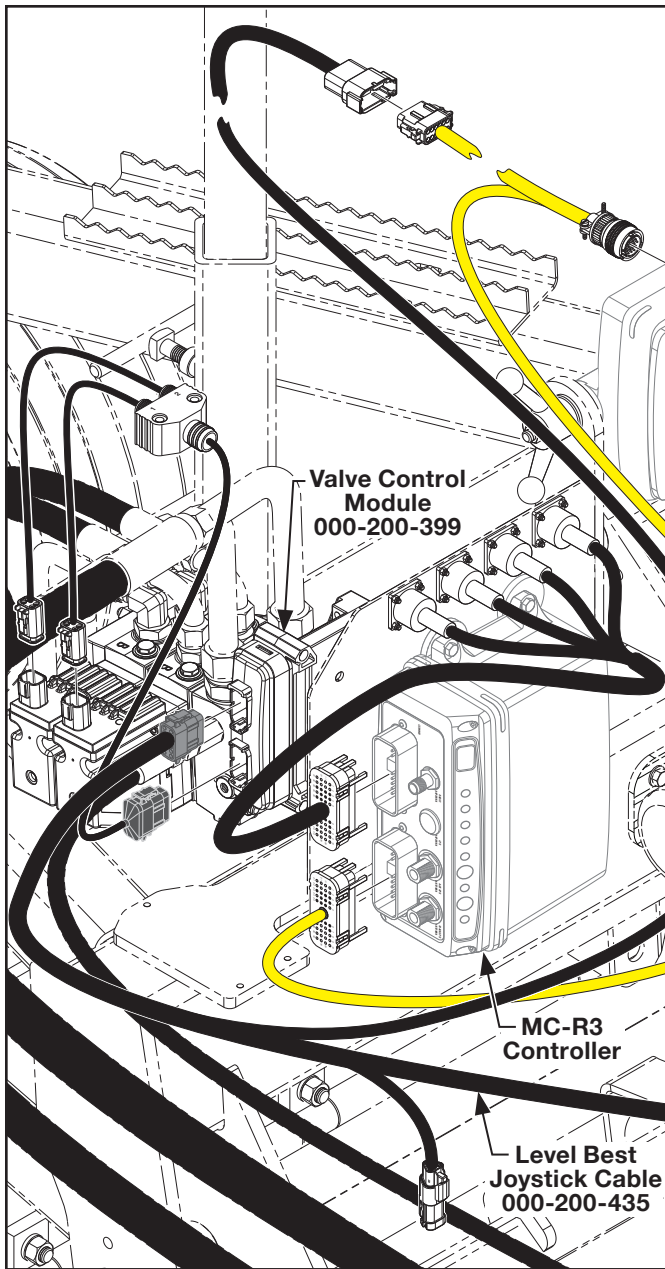

Figure 3-5. Level Best Joystick Harness

If the optional joystick is to be installed (see [Figure 3-6](#)), plug the joystick cable. Install the vacuum cup as described in Vacuum Cup on [page 7.5](#).

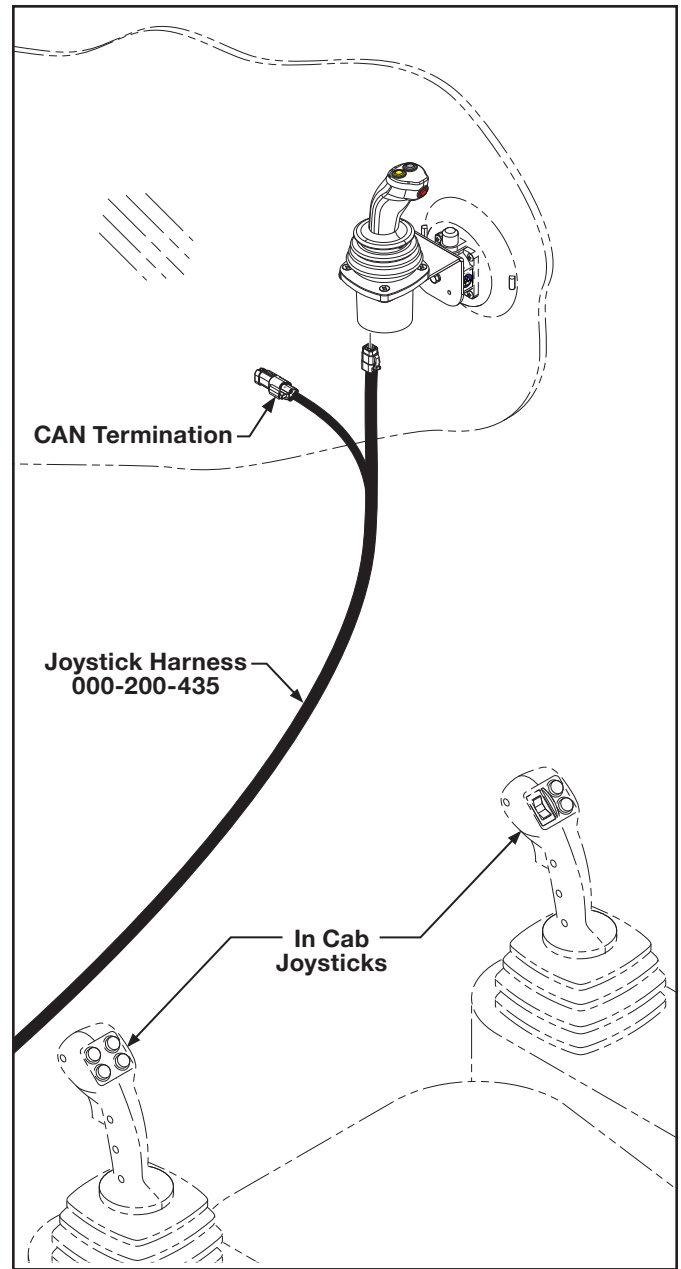

Figure 3-6. Joystick with Cable

Auxiliary joystick - A standalone joystick (see [Figure 3-2](#)) provides selection of automatic and manual control. When in manual control, the grading box can be raised and tilted as desired (see [Figure 1-2. Joystick Functions on page 1.1](#)). A suction cup allows installation of the joystick on a side window.

(for future use)

Figure 4-1. General Arrangement for Integrated Machine Harness.....	4.2
Figure 4-2. General Arrangement Universal Joystick.....	4.4
Figure 4-3. Module Controller	4.6
Figure 4-4. Valve Module Cable	4.6
Figure 4-5. Level Best Joystick Harness.....	4.7
Figure 4-6. Joystick with Cable	4.7

TOPCON SYSTEM 5

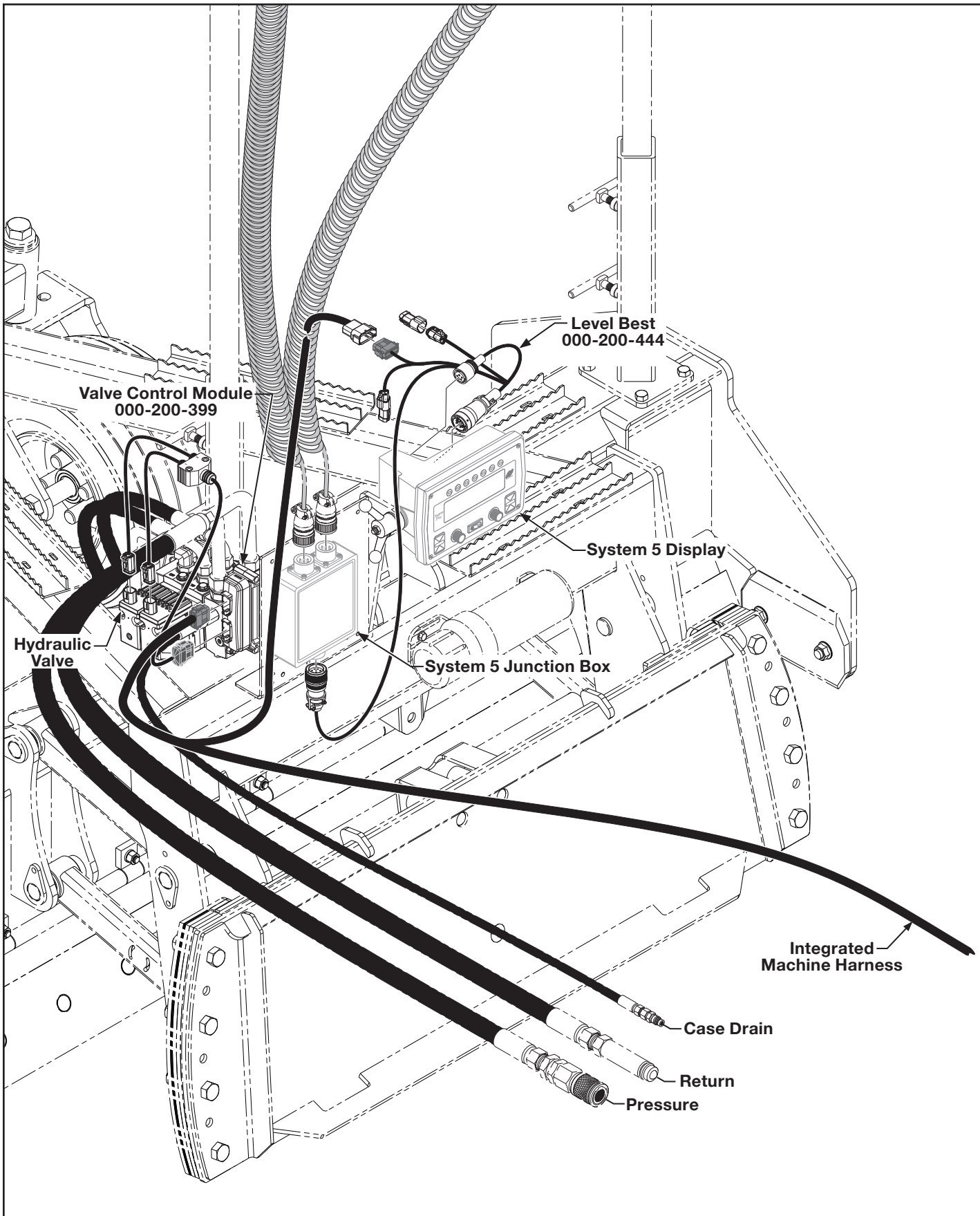

Figure 4-1. General Arrangement for Integrated Machine Harness

Topcon Configuration

NOTE: To ensure proper communication with the Level Best hydraulic control system, the Topcon Control Panel must be configured by an authorized Topcon representative.

To allow the Topcon Control Panel to properly address the Level Best hydraulic control valve, the following must be set:

The “Valve Input” must be set to *CNH CAN*.

The “Input Device” must be set to *CAN Input*.

NOTE: If required, run a wire from the loader’s back-up alarm to the ‘Back-up Alarm’ plug on the Breakout A harness. This needs to be a simple 12 V signal.

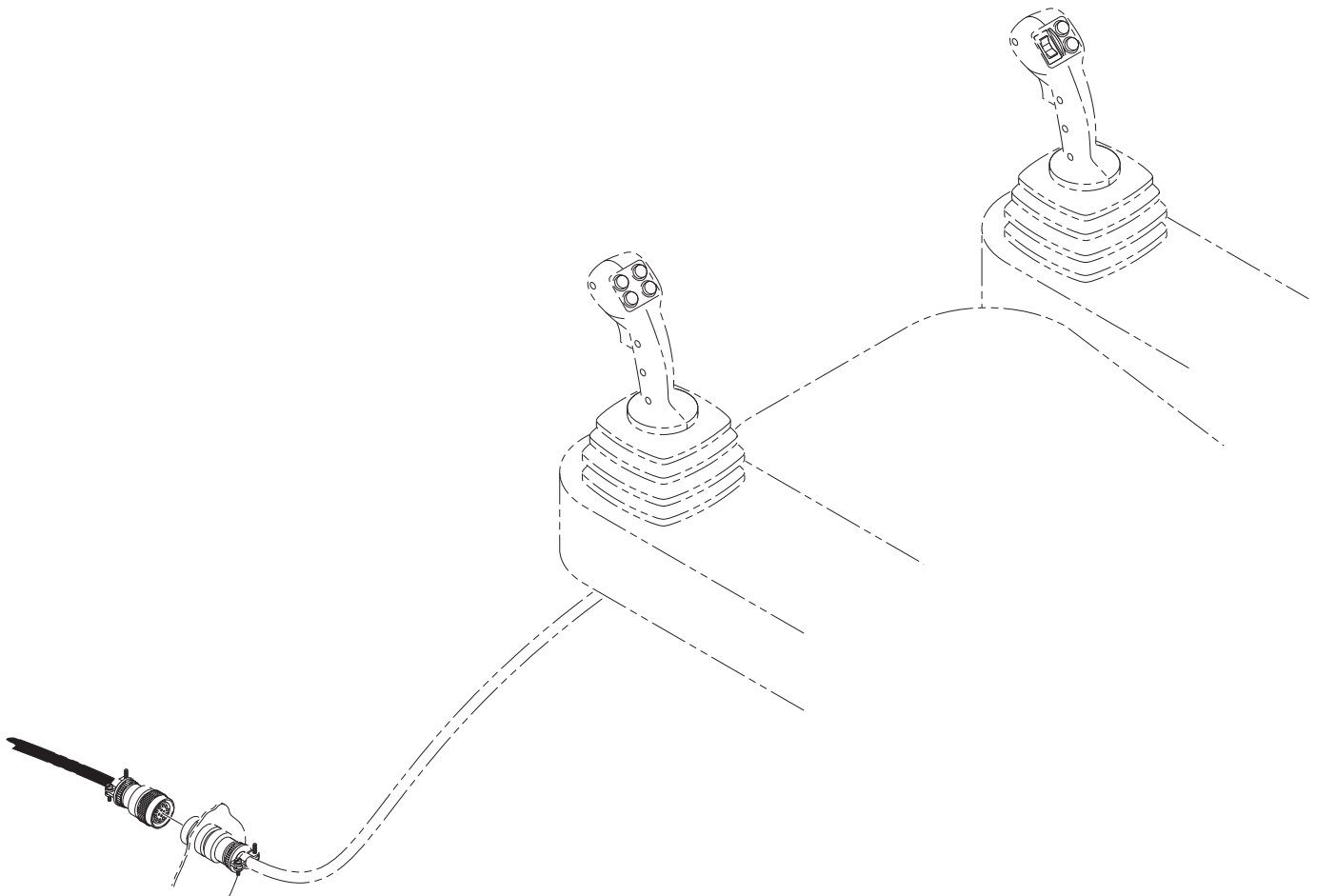
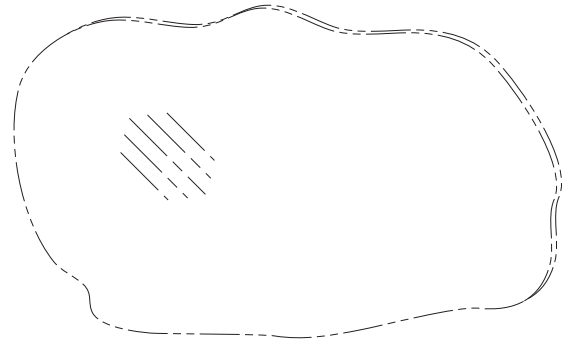

TOPCON SYSTEM 5

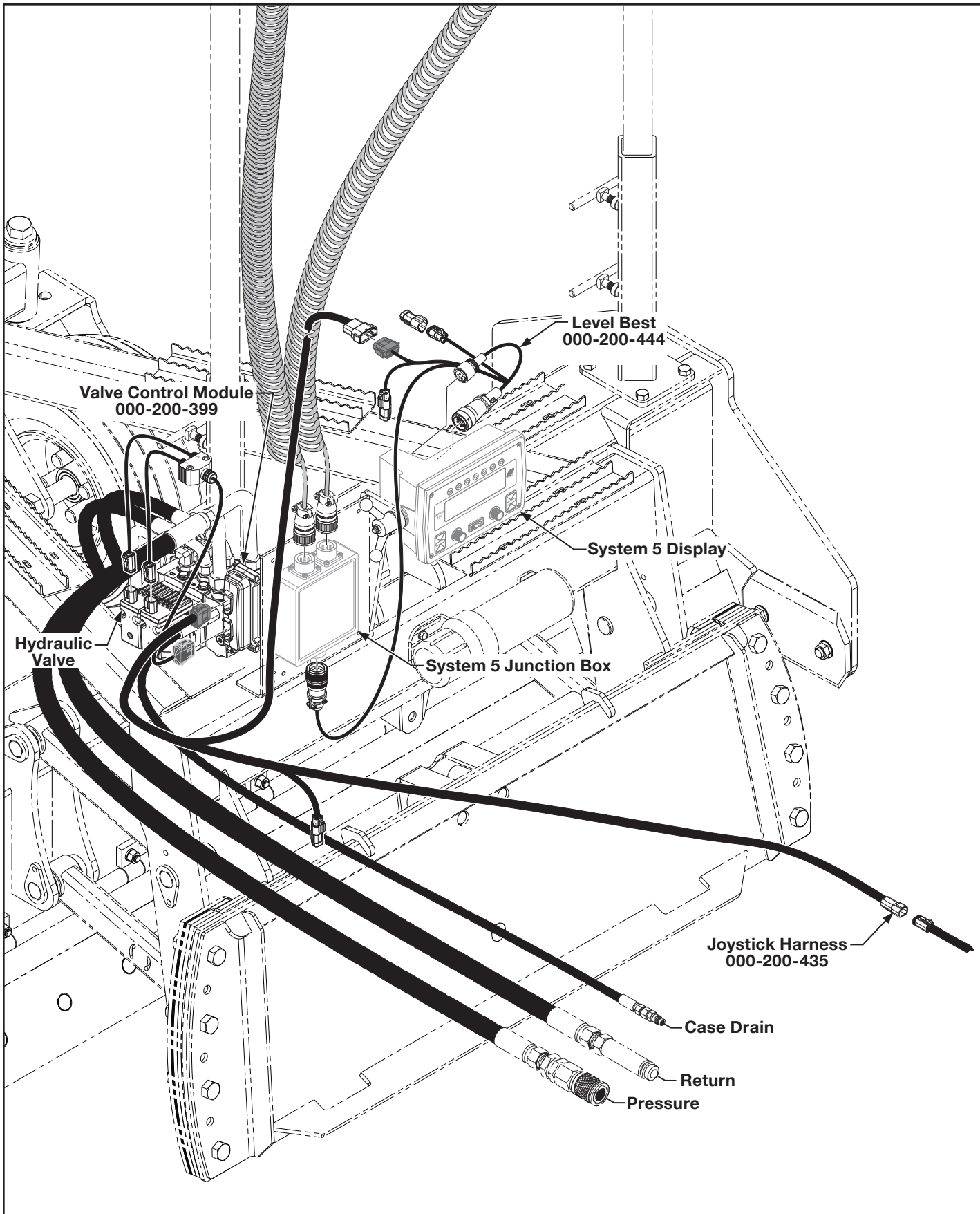

Figure 4-2. General Arrangement Universal Joystick

Topcon Configuration

NOTE: To ensure proper communication with the Level Best hydraulic control system, the Topcon Control Panel must be configured by an authorized Topcon representative.

To allow the Topcon Control Panel to properly address the Level Best hydraulic control valve, the following must be set:

The "Valve Input" must be set to *CNH CAN*.

The "Input Device" must be set to *CAN Input*.

NOTE: If required, run a wire from the loader's back-up alarm to the 'Back-up Alarm' plug on the Breakout A harness. This needs to be a simple 12 V signal.

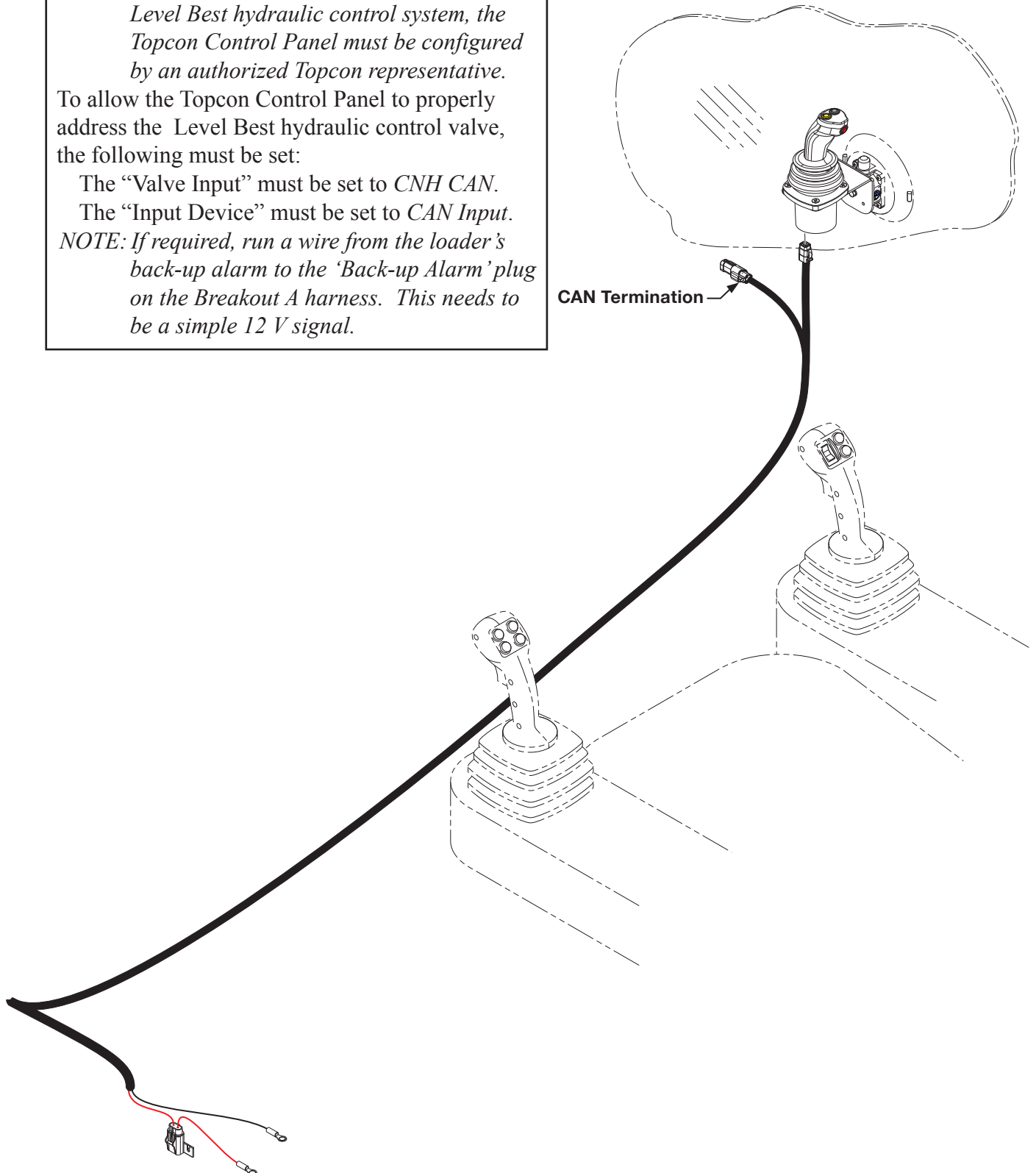

Connection of the Module Controller

The Module Controller provides the electronic interface between the Topcon control system in the cab and the hydraulic valve.

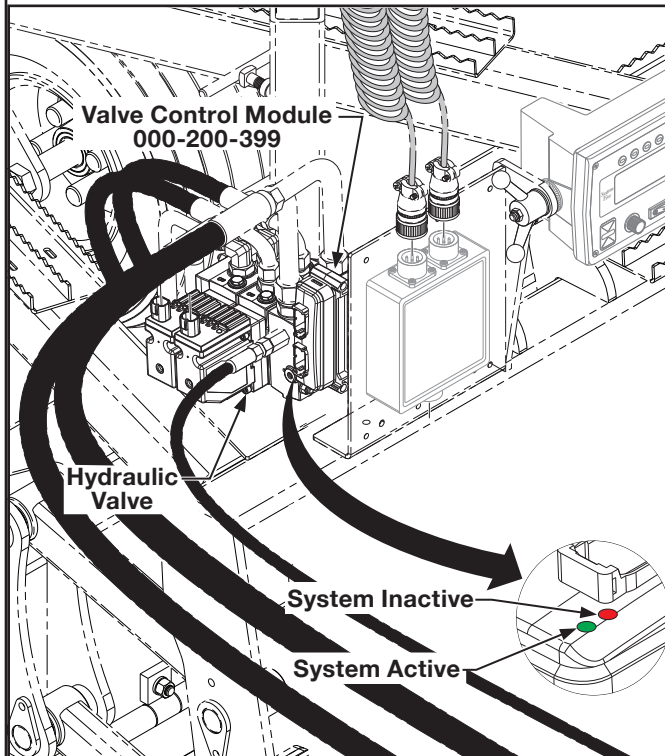

Figure 4-3. Module Controller

Connecting the two components is the Valve Module Cable (see [Figure 4-4](#)). Each connector to the valve is keyed to prevent insertion into the wrong socket. In the same way, the Module Controller end may only be inserted into the correct socket.

NOTE: Never force a plug into a socket. Plugs are keyed to prevent incorrect insertion.

Two LEDs indicate the operating status of the Module Controller.

The green LED indicates that power is applied and the system is operating normally.

The red LED indicates an error in the communications system. The wire connections should be checked and, if this does not solve the issue, contact your local Topcon service department.

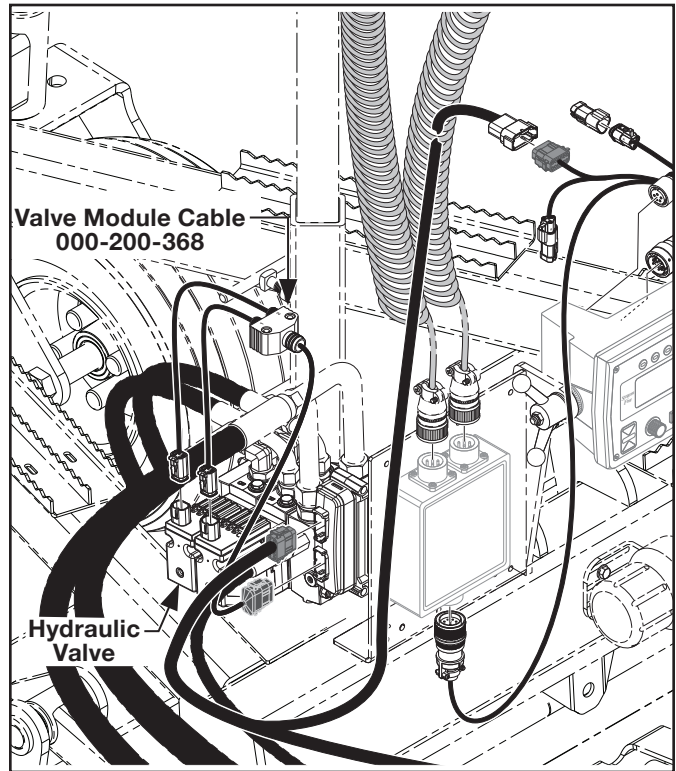

Figure 4-4. Valve Module Cable

The Module Controller also connects to the joystick cable (see [Figure 4-5](#)) note that this cable includes a connector to allow the grading box to be removed from the skid steer without fully removing the cable from the machine.

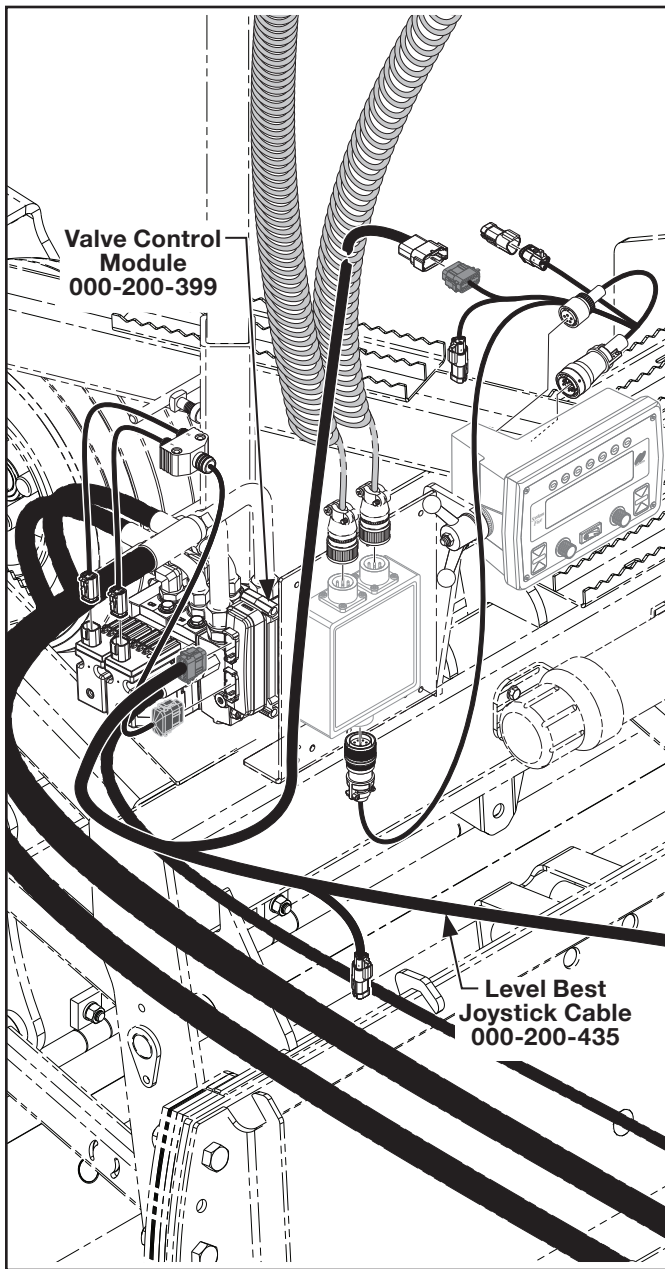

Figure 4-5. Level Best Joystick Harness

If the optional joystick is to be installed (see [Figure 4-6](#)), plug the joystick cable. Install the vacuum cup as described on [page 7.5](#).

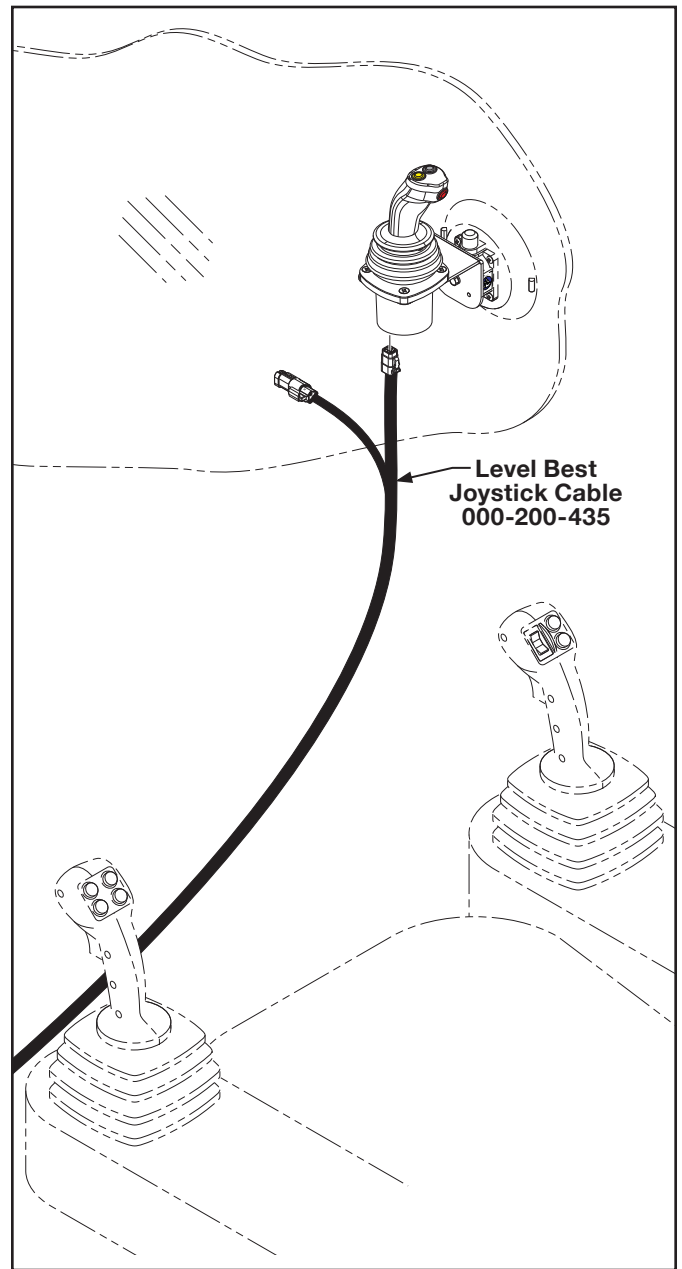

Figure 4-6. Joystick with Cable

Auxiliary joystick - A standalone joystick (see [Figure 4-2](#)) provides selection of automatic and manual control. When in manual control, the grading box can be raised and tilted as desired (see [Figure 1-2. Joystick Functions on page 1.1](#)). A suction cup allows installation of the joystick on a side window.

(for future use)

Figure 5-1. General Arrangement for Earthworks GO 5.2
Figure 5-2. Earthworks GO Laser Receiver, Cables and Box 5.3

TRIMBLE EARTHWORKS GO

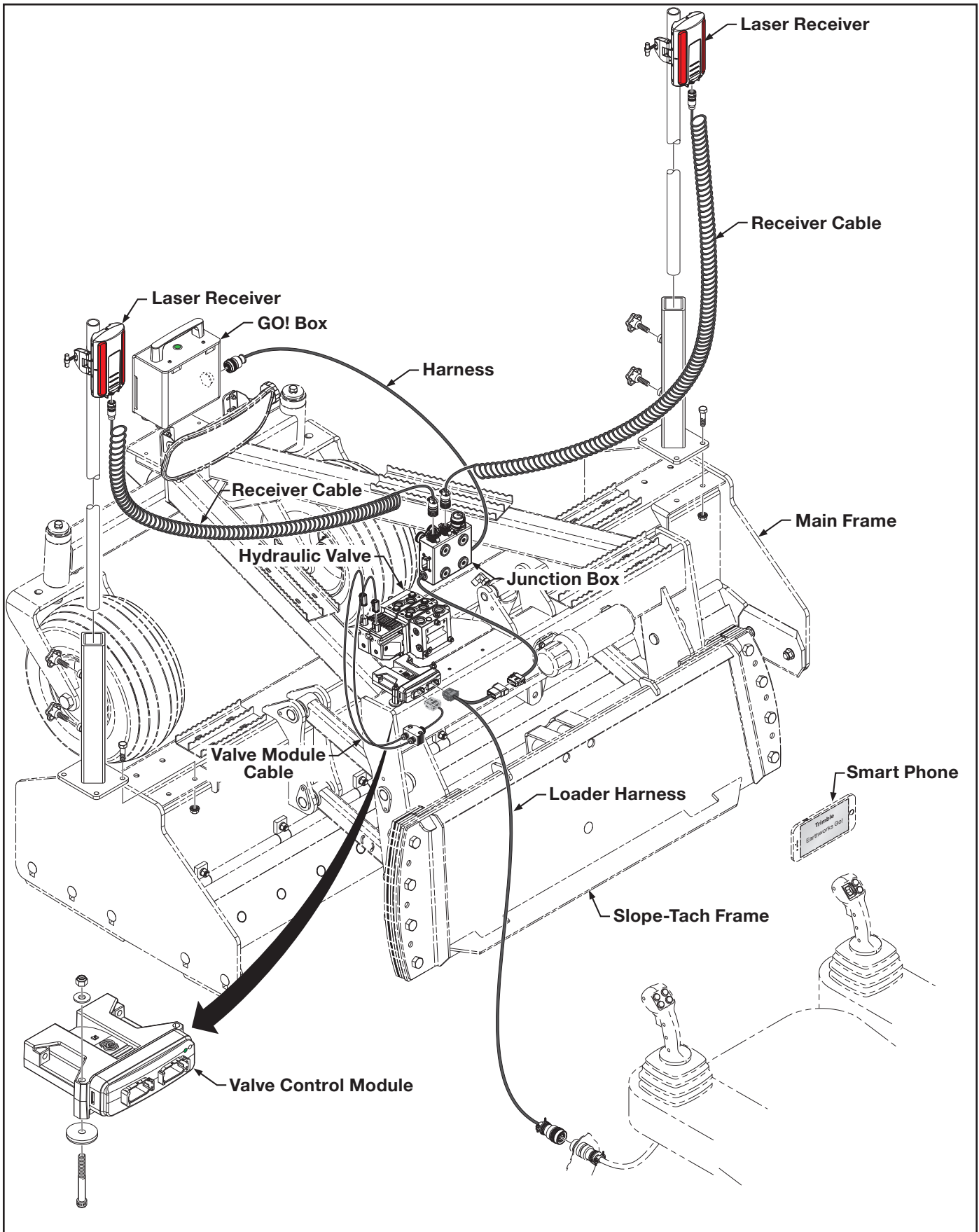

Figure 5-1. General Arrangement for Earthworks GO

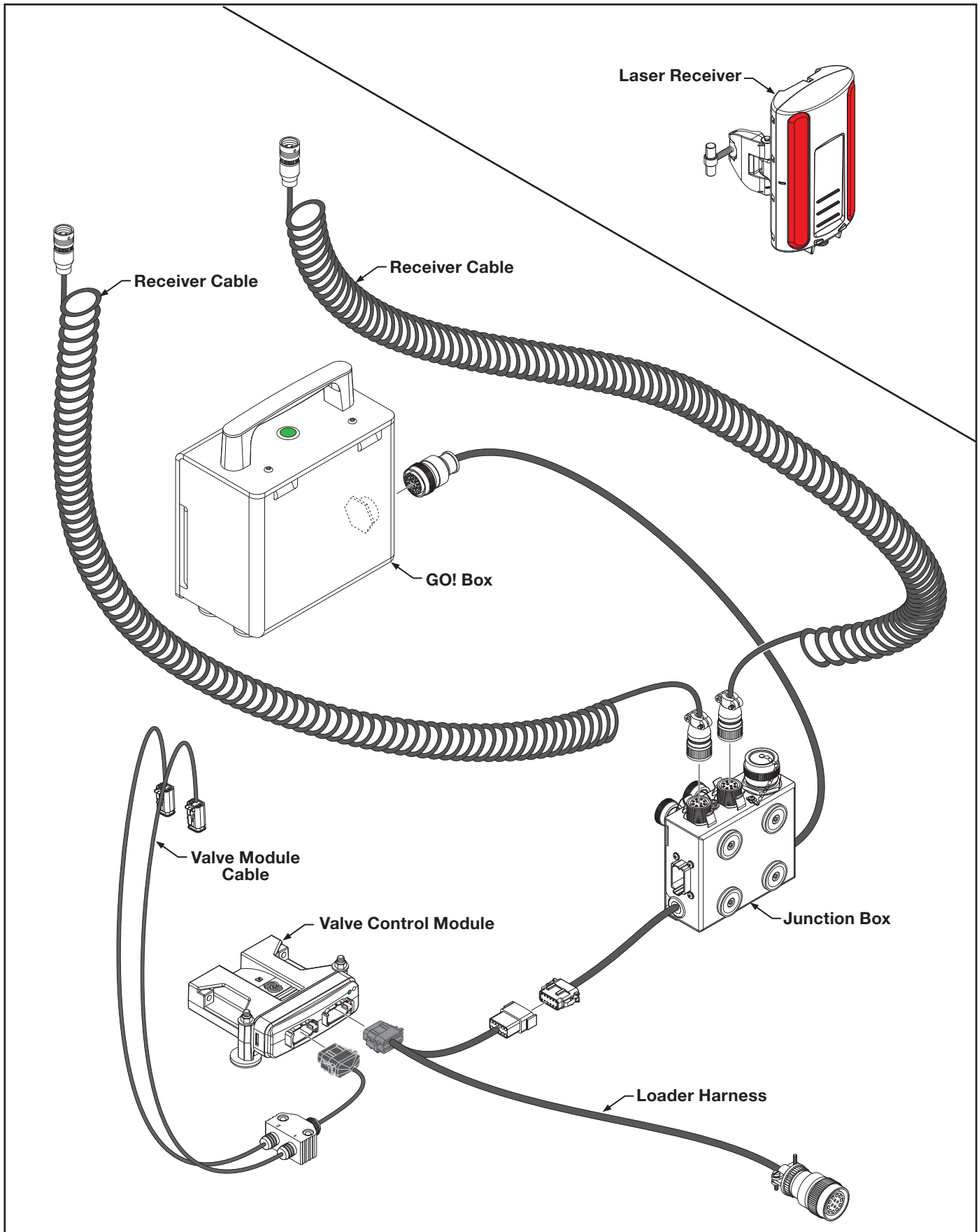

Figure 5-2. Earthworks GO Laser Receiver, Cables and Box

(for future use)

SPECIFICATIONS AND MAINTENANCE

SPECIFICATIONS

Dimensions

Model	PD-72	PD-84	PD-96
Box Width	72 in. (183 cm)	84 in. (213 cm)	96 in. (244 cm)
Overall Width	75.25 in. (191 cm)	87.25 in. (222 cm)	99.25 in. (252 cm)
Total Length	71.25 in. (181 cm)		
Box Capacity, Front	11.5 ft ³ (0.33 m ³)	13.4 ft ³ (0.38 m ³)	15.3 ft ³ (0.43 m ³)
Box Capacity, Rear	7.0 ft ³ (0.20 m ³)	8.0 ft ³ (0.23 m ³)	9.0 ft ³ (0.25 m ³)
Weight	1885 lbs. (855 kg)	1935 lbs. (878 kg)	1985 lbs. (900 kg)

PD Series Hydraulic Valve

Valve Type	Danfoss PVG32
Minimal Flow Rate	12 GPM (45.4 LPM)
Maximum Flow Rate	28 GPM (106 LPM)
Maximum Hydraulic Pressure	4060 psi (280 bar)

MAINTENANCE

The rugged and durable Level Best grading box is built to last, but as with all equipment, a few minutes of routine care, maintenance, and cleaning can extend the life of the system.

Storage and Transport

Most often the grading box and its hydraulic controls remain on the machine. However, the Automatic Control System components should be stored in a safe, protected place when not in use. Protect the cable connections by installing the covers supplied.

Cleaning

The Control Panel is water-resistant. It can be cleaned with mild soap, water, and a damp, soft cloth. Do not submerge the Control Panel or direct high pressure spray at it. Do not use a dry cloth to wipe the laser receiver or Control Panel as scratching may occur.

Cables and Hoses

Check all cables and hoses regularly for signs of wear and damage. Keep cable connections clean and free from dirt and corrosion. If a cable has been damaged, do not attempt to repair. Incorrect or poor connections can cause damage to your Automatic Control System.

When applicable, check the hydraulic hoses. Look for areas where the hoses could rub against each other or another object as they expand and contract under pressure. Check the hydraulic fittings for tightness.

Machine

Check areas that affect the Automatic Control system function and accuracy, such as looseness or play in the cylinders or wear on the box's cutting edge. Looseness in the connection to the skid steer, such as in the adaptor plate, will cause inaccurate depth positioning.

Also check the skid steer routinely for wear to its components, such as loader pins and quick-attach linkage, ensuring it is operating properly.

SPECIFICATIONS AND MAINTENANCE

Loader Hydraulics

Change the oil and filter per loader manufacturer recommendations to ensure proper function of your Level Best grading box.

SERVICE

If the Automatic Control System is not functioning properly, the first step is to determine the problem component. Use the Troubleshooting Chart to determine possible causes and remedies. The following test equipment is needed:

- Voltage/Ohm Meter
- Rotating Laser or Laser Simulator

Cable Wiring Diagrams and troubleshoot electrical problems contact your local Machine Control Dealer.

Shims and Slide Pads

The slope portion of the Level Best grading box rides on two non-greaseable oil-impregnated plastic retaining pads. These pads may wear over time and shims may need to be removed to ensure a tight fit. Periodically check the pads for signs of wear or gaps between the pad material and the metal plate. If required, remove the 1/16-inch shim (do not discard) by removing the bolts as shown. Do each side, one at a time, ensuring that the bolts are tight before moving to the other side.

Every Level Best attachment is tested before leaving the factory. But if, after a wear-in period, the slope portion still seems tight, contact ATI Group, LLC for additional shims if required.

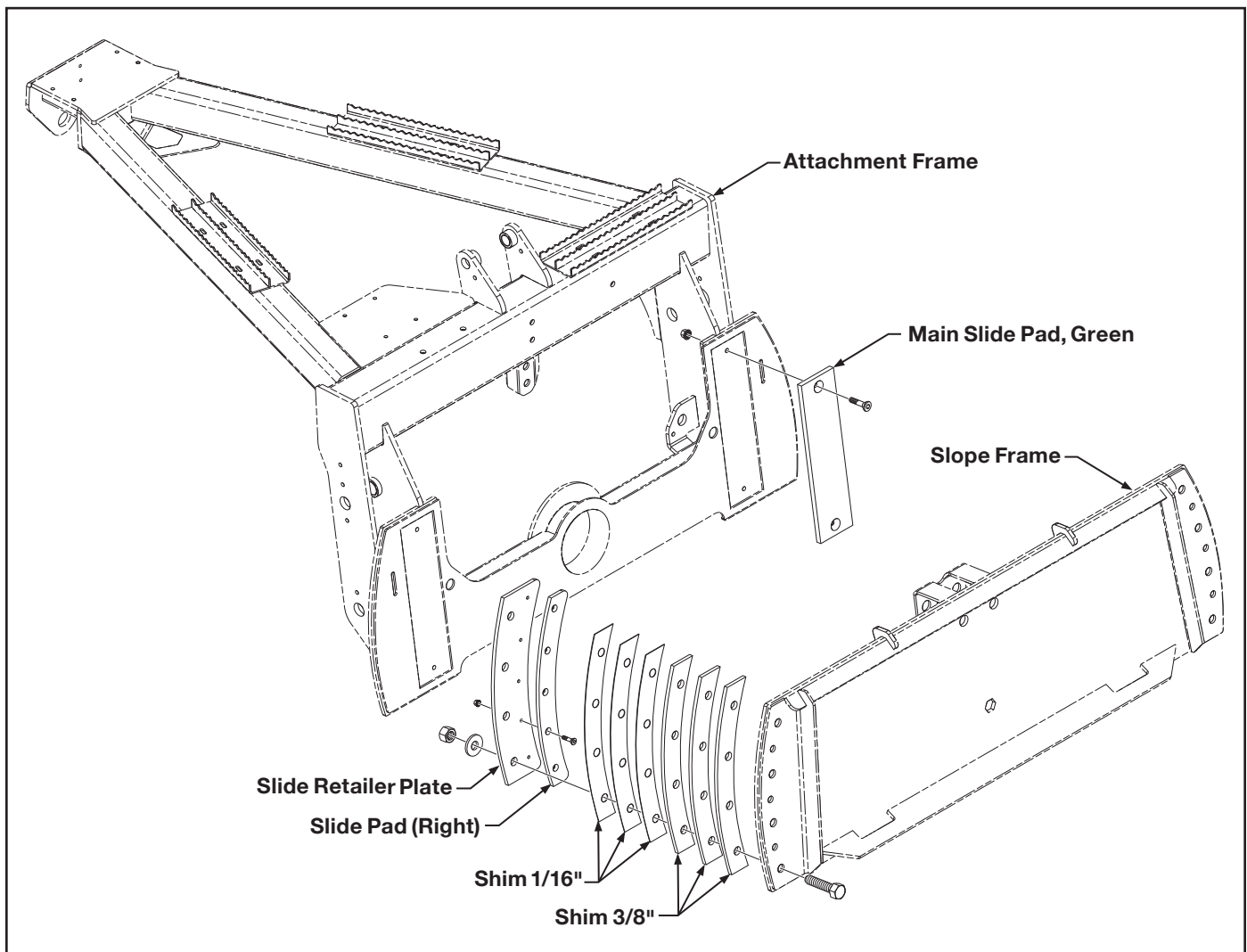

Figure 6-1. Shims and Slide Pads

SPECIFICATIONS AND MAINTENANCE

HUB GREASING INSTRUCTIONS

The hub bearings on Level-Best products are pre-greased from factory for a long service life. However, it is strongly suggested that the axle and hub assembly be removed and disassembled annually to repack with grease and inspect the bearings for wear or damage.

The hubs now have an option to add grease through a zerk during routine maintenance. When greasing the hubs with this method please adhere to the following guidelines:

DO NOT OVER GREASE the bearings. One or two shots of grease every 100 operating hours is sufficient to keep the bearings lubricated. Forcing excessive amounts of grease into the hub will push the seals off their seats and expose the bearings to external dirt, use a Multi-Purpose grease.

Adding external grease is no replacement for proper maintenance practices. Annual tear-down and repacking of the bearings is still required to ensure a long life of the machine and minimal downtime.

NOTE: Check Hydraulic System Components for wear and/or leaks.

Check and tighten all bolts and nuts for scraper blade and end blades, weekly.

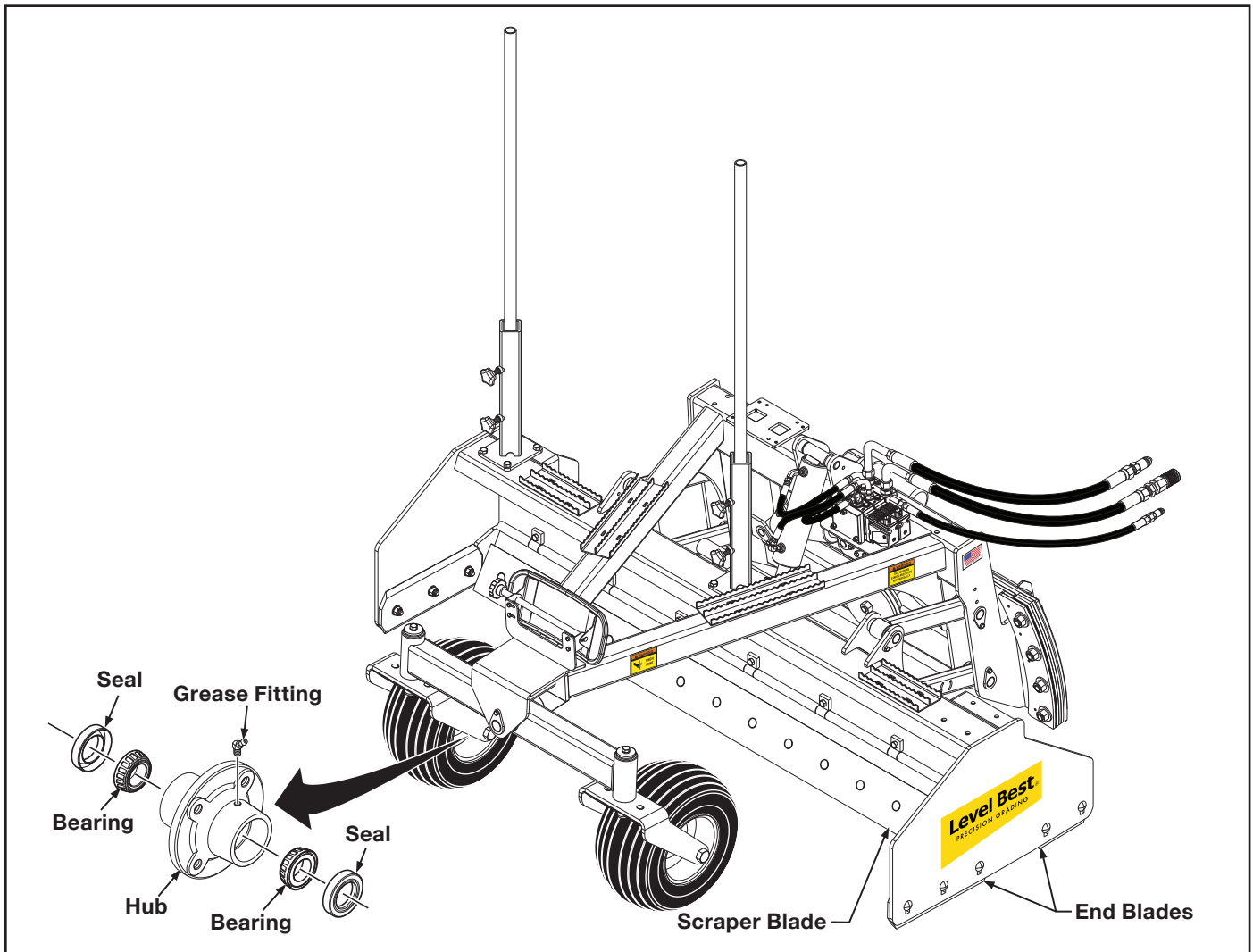

Figure 6-2. Lube and Maintenance

HYDRAULICS

Hydraulic Valve

The hydraulic valve is setup at the factory and should not need any adjustments. If there are any changes required, they should be done by an authorized factory technician.

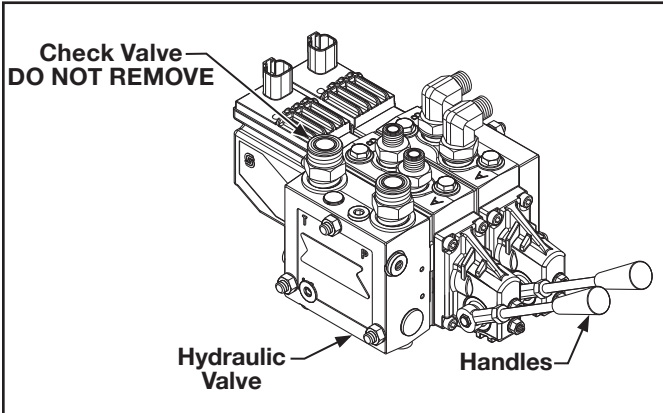

Figure 6-3. Hydraulic Valve

NOTE: Do not remove the check valve. Removal will void the warranty.

The handles are for manual actuation of the valve, can be found in canister.

Hydraulic Hose Connection

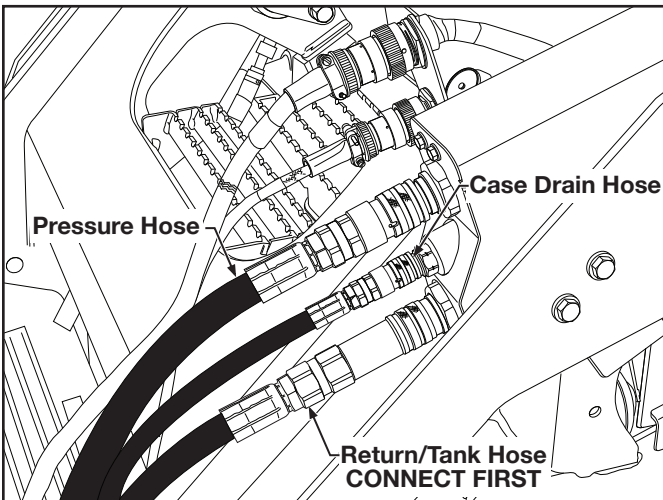

Figure 6-4. Hydraulic Hose Connections to Skid Steer

CAUTION

The return line must be connected before the pressure line. Pressurizing the valve without an outlet will damage the valve and void the valve warranty.

NOTE: Check the manufacture of your skid steer for the correct hose connections.

SPECIFICATIONS AND MAINTENANCE

VACUUM CUP



WARNING: This product can expose you to chemicals including diethylhexyl phthalate (DEHP, which is known to the State of California to cause cancer and birth defects or other reproductive harm.

For more information go to www.P65Warnings.ca.gov.

Installation

1. Clean the mounting surface and, if needed, the face of the vacuum cup (see **Cleaning**).
2. Position the cup on the mounting surface so the plunger is accessible and visible to the operator.
3. Pump the plunger until the cup attaches completely. When the red line on the plunger is hidden, the cup is ready for use.
4. Check the plunger frequently to make sure the cup remains securely attached. If the red line appears, pump the plunger until the red line is hidden again.

Release

1. Grasp and hold the joystick and cup assembly.
2. Pull one of the release tabs until the cup disengages completely.

CAUTION

Remove the cup when not in use. If the cup remains attached to a hot surface (e.g., in direct sunlight) for an extended period, the rubber pad could bond to the mounting surface, resulting in damage to the surface or to the pad when it is removed.

Maintenance Service

Regularly make sure the vacuum cup's air filter is in place. If not, discontinue use until the filter is replaced.

Since aging and water reduce the capacity of the rubber pad, it should be replaced at least once every 2 years or whenever damage is discovered.

If the cup does not function normally, the cup face may be dirty or damaged, or the pump may require service. First clean the cup face as directed.

Cleaning

1. Remove the air filter from the cup face.
2. Use a clean sponge or lint-free cloth to apply soapy water or another mild cleanser to cup face.

CAUTION

To prevent liquid from contaminating the pump, hold the cup face-down or cover the suction hole in the filter recess while using any liquid.

3. Wipe all residue from the cup face.
4. Allow the cup to dry and reinstall the air filter.

Storage

Store in a clean, dry location out of direct sunlight. Protect the cup face from damage using the pad cover (when supplied) or another appropriate means.

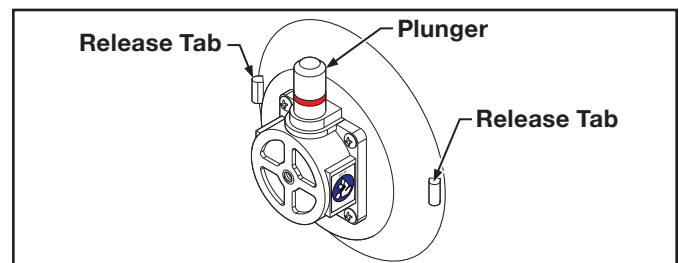

Figure 6-5. Vacuum Cup

Figure 2-1 through **Figure 2-13** show the functions and pinouts of the various integrated control systems based on the skid steer manufacturer. Only the functions and pinouts used are specified.

SPECIFICATIONS AND MAINTENANCE

(for future use)

TROUBLESHOOTING

SYMPTOM	POTENTIAL CAUSE	REMEDY
Grading box has trouble staying on grade.	Rotating laser out of range.	Ensure laser receiver is within specified range of rotating laser.
	Laser beam being reflected.	Ensure rotating laser's light is not reflecting off outer surfaces (windows, windshields, mirrors, etc.) causing multiple readings by the laser receivers.
	Multiple laser beams.	Ensure that there are no other lasers operating on the job site or nearby.
	Laser deadband set too narrow.	Ensure the deadband (accuracy) setting is appropriate for rough grading.
	Travel speed is too fast for grade tolerance.	Slow down.
	Hydraulic response too quick.	Decrease the valve speed setting.
Grading box doesn't return all the way to on grade.	Valve offsets need to be raised.	Call dealer.
Grading box keeps driving past on grade, and bouncing.	Valve offsets need to be lowered.	Call dealer.
Grading box doesn't follow receiver or control panel grade display.	Valve cables are connected to wrong sides.	Check to make sure the valve cable branches are hooked up properly. Elevation (left) branch of cable to the Elevation (left) Receptacle on the Valve, and Slope (right) branch of cable to the Slope (right) Receptacle on the Valve.

TROUBLESHOOTING

SYMPTOM	POTENTIAL CAUSE	REMEDY
Grading box does not raise or lower.	<p>Control Panel not turned on.</p> <p>No hydraulic flow to grading box.</p> <p>Cables not connected correctly.</p> <p>Electrical problems.</p> <p>Hydraulic problems.</p>	<p>Push the power switch.</p> <p>Ensure hydraulic control handle of skid steer is in correct position.</p> <p>Ensure auxiliary hydraulics are on or in continuous flow mode.</p> <p>Check valve cable, valve and valve coils for visible damage.</p> <p>Move directional valve spool manually using the overrides, with the handles provided in Manual Canister. (see Figure 6-3.)</p> <div style="background-color: #ff9900; padding: 5px; text-align: center; border: 1px solid black;">  WARNING </div> <p>Be sure to stay clear of any moving parts of the grading box.</p> <p>If the grading box moves, refer to Electrical problems. If the grading box does not move, refer to Hydraulic problems.</p> <p>Check valve cable, valve and valve coils for visible damage.</p> <p>Use an ohmmeter to check cable for continuity. Contact ATI Group, LLC for pinouts.</p> <p>Confirm hydraulic flow through the manifold and returning to the power source through the “T” hose.</p> <p>Contact ATI Group, LLC for help troubleshooting the hydraulic manifold.</p>
Grading box moves in unexpected/erratic direction.	Solenoid cable installed incorrectly.	<p>Verify termination marked “Elevation” is installed in socket of elevation bank on Danfoss valve. Confirm respective termination on slope bank.</p>

PARTS ILLUSTRATIONS

Parts Illustrations	9.1
Serial Number Information	9.2
Where To Get Parts And Service	9.2
How To Order Parts	9.2
List of Parts Illustrations	9.3

Serial Number Information

It is very important that the correct serial number is provided when ordering parts. The serial number plate is located on the main frame. Please mark the model and serial number of your Para-Level Grading Box in the space provided below in case the plate on your Para-Level Grading Box gets lost or damaged.

Model..... **Serial Number**

Dealer Name **Dealer Phone Number**

Where To Get Parts And Service

When replacement parts and service are required, ATI Group, LLC recommends returning to the dealer from which the product or optional kit was purchased. By going to the dealer, you are dealing with people that understand and know ATI products. Our dealers have the experience servicing these machines and stock the most common parts required to keep your equipment in top working condition.

How To Order Parts

Parts lists contained in this book have been prepared to help you when ordering spare and/or replacement parts. Your order will be filled promptly and accurately when the following information is provided:

1. Model and serial number of the unit. (This specifically identifies the equipment you have and permits us to verify the part numbers in your order.)
2. The parts list page number and catalog number. Include catalog revision number, if applicable.
3. The **Item** number for each part. **Item** numbers on the parts list page correspond with the numbers shown on the illustration.
4. **Part Number** as it appears in the parts list. In most cases this will be a nine-digit number; for example: 315-005-000.
5. The **Description** for the part as it appears on the parts list page.

When a complete assembly is needed, use the assembly number given in the parts list. If no assembly number is given, order by main assembly title and list only the item numbers you want. For example: “Wheel Frame Assembly per 315-509-000, Items 2 through 8, inclusive”.

The part ordered may have a new part number, or the part may have been replaced by a newer design with a different part number. In these cases your acknowledgement, shipping papers and invoices will be written listing the current part number first; the old part number you referred to will follow the part description.

Our purpose in doing this is to tell you that the parts are fully interchangeable. This will avoid any unnecessary correspondence or delay in processing your order. We suggest that you add any new number to your parts lists for future use.

NOTE: ATI Group, LLC reserves the right to discontinue models at any time, change specifications, and improve design without notice and without incurring obligation on goods previously purchased and to discontinue supplying any part listed, when the demand does not warrant production.

LIST OF PARTS ILLUSTRATIONS

Figure 8-1. Main Frame and Cutting Edges	8.4
Figure 8-2. Attachment Frame and Related Parts	8.6
Figure 8-3. Caster Fork and Wheel	8.8
Figure 8-4. Hydraulics & Related Parts	8.10
Figure 8-5. Hydraulic Valve Assembly	8.12
Figure 8-6. Hydraulics Slope Cylinder, Fittings and Related Parts	8.14
Figure 8-7. Slope Frame, Shims and Related Parts	8.16
Figure 8-8. Laser Controls and Related Parts - Trimble Earthworks Go!	8.18
Figure 8-9. Box, Laser Receiver 360°, Cables - Trimble Earthworks Go!	8.20
Figure 8-10. Decals	8.22

PARTS ILLUSTRATIONS

Figure 8-1. Main Frame and Cutting Edges

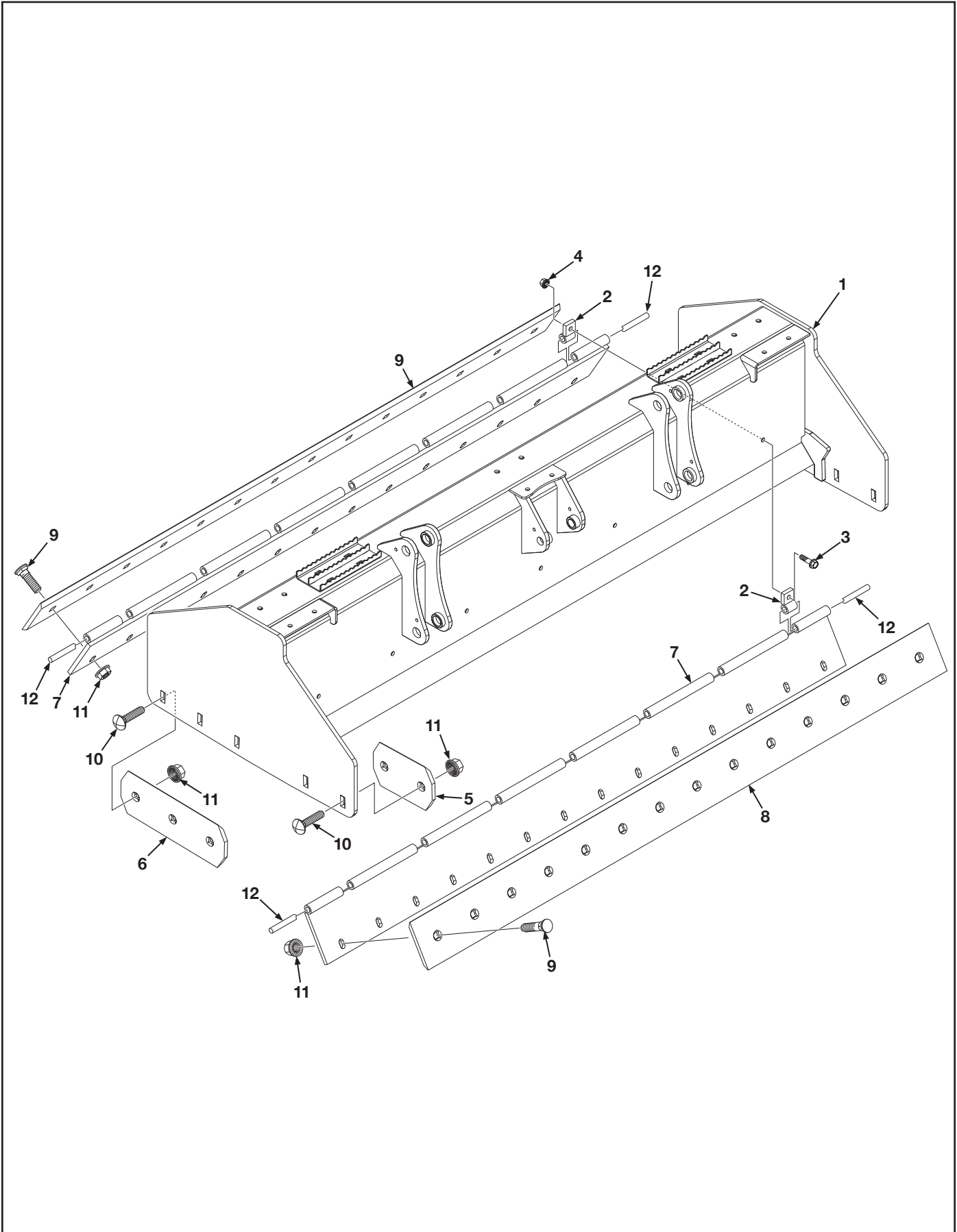

PARTS ILLUSTRATIONS

Figure 8-1. Main Frame and Cutting Edges

Item	Part No.	Qty	Description
1	315-101-100	1	Frame, Main 6'
	315-102-100	1	Frame, Main 7'
	315-103-100	1	Frame, Main 8'
2	315-561-010	14	Hinge, Back Plate, 6' & 7'
	315-561-010	18	Hinge, Back Plate, 8'
3	000-150-376	AR	Bolt, Flange Head, 1/2"-13UNC x 2" Long
4	000-158-111	AR	Nut, Serrated Flange, 1/2"-13UNC
5	000-190-150	2	Edge, Cutting, End, DBF, 9-1/2" Long
6	000-190-149	2	Edge, Cutting, End, DBF, 16-3/4" Long
7	315-563-100	2	Mount Assembly, Blade 6'
	315-564-100	2	Mount Assembly, Blade 7'
	315-565-100	2	Mount Assembly, Blade 8'
8	000-190-075	2	Edge, Cutting, DBF, 72" Long
	000-190-077	2	Edge, Cutting, DBF, 84" Long
	000-190-079	2	Edge, Cutting, DBF, 96" Long
9	000-150-258	AR	Bolt, Plow, 5/8"-11UNC x 1-3/4" Long
10	000-150-253	10	Bolt, Carriage, 5/8"-11UNC x 1-3/4" Long
11	000-158-142	AR	Nut, Serrated Flange, 5/8"-11UNC
12	000-161-127	2	Pin, Hinge, 6'
	000-161-128	2	Pin, Hinge, 7'
	000-161-129	2	Pin, Hinge, 8'

AR - As Required NSS - Not Serviced Separately ASN - After Serial No. BSN - Before Serial No. LP - Local Purchase

PARTS ILLUSTRATIONS

Figure 8-2. Attachment Frame and Related Parts

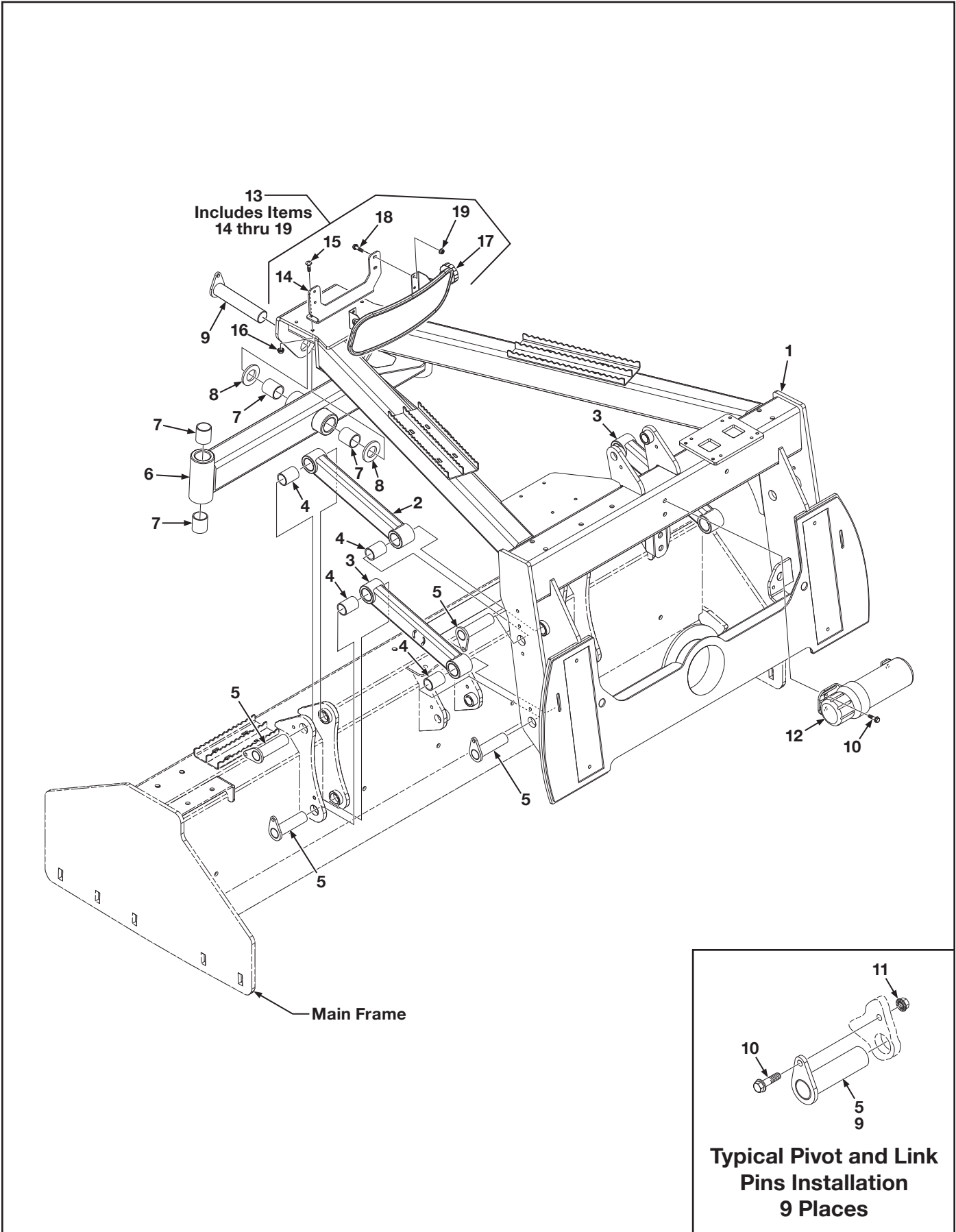

PARTS ILLUSTRATIONS

Figure 8-2. Attachment Frame and Related Parts

Item	Part No.	Qty	Description
1	315-631-000	1	Frame, Attachment
2	315-621-100	2	Link, Lift, Box, Includes Item 4
3	315-621-000	1	Link, Lift, Torsion, Box, Includes Item 4
4	000-176-183	8	Bushing, Link, 1-1/2" OD x 1-1/4" ID x 2" Long
5	000-161-165	8	Pin, Link, 1-1/4" Dia x 4-5/8" Long
6	315-568-000	1	Axle Assembly, Front, Includes Item 7
7	000-176-171	6	Bushing, Wheel Frame, 1-3/4" OD x 1-1/2" ID x 1-1/2" Long
8	000-155-013	2	Bushing, Washer, 2-3/4" OD x 1-1/2" ID x 10 Gauge
9	000-161-166	1	Pin, Pivot, 1-1/2" Dia. x 7-3/4" Long
10	000-150-078	12	Bolt, Serrated Flange, 5/16"-18UNC x 1" Long
11	000-158-064	9	Nut, Serrated Flange, 5/16"-18UNC
12	001-001-083	1	Canister, Operators Manual
13	001-001-141	1	Kit, Mirror & Bracket, Includes Items 14 thru 19
14	001-001-140	1	Bracket, Mounting
15	000-150-372	2	Bolt, Carriage, 5/16"-18UNC x 1" Long
16	000-158-064	2	Nut, Serrated Flange, 5/16"-18UNC
17	001-001-097	1	Mirror
18	000-150-046	4	Bolt, Serrated Flange, 1/4"-20UNC x 1/2" Long
19	000-158-048	4	Nut, Serrated Flange, 1/4"-20UNC

AR - As Required NSS - Not Serviced Separately ASN - After Serial No. BSN - Before Serial No. LP - Local Purchase

PARTS ILLUSTRATIONS

Figure 8-3. Caster Fork and Wheel

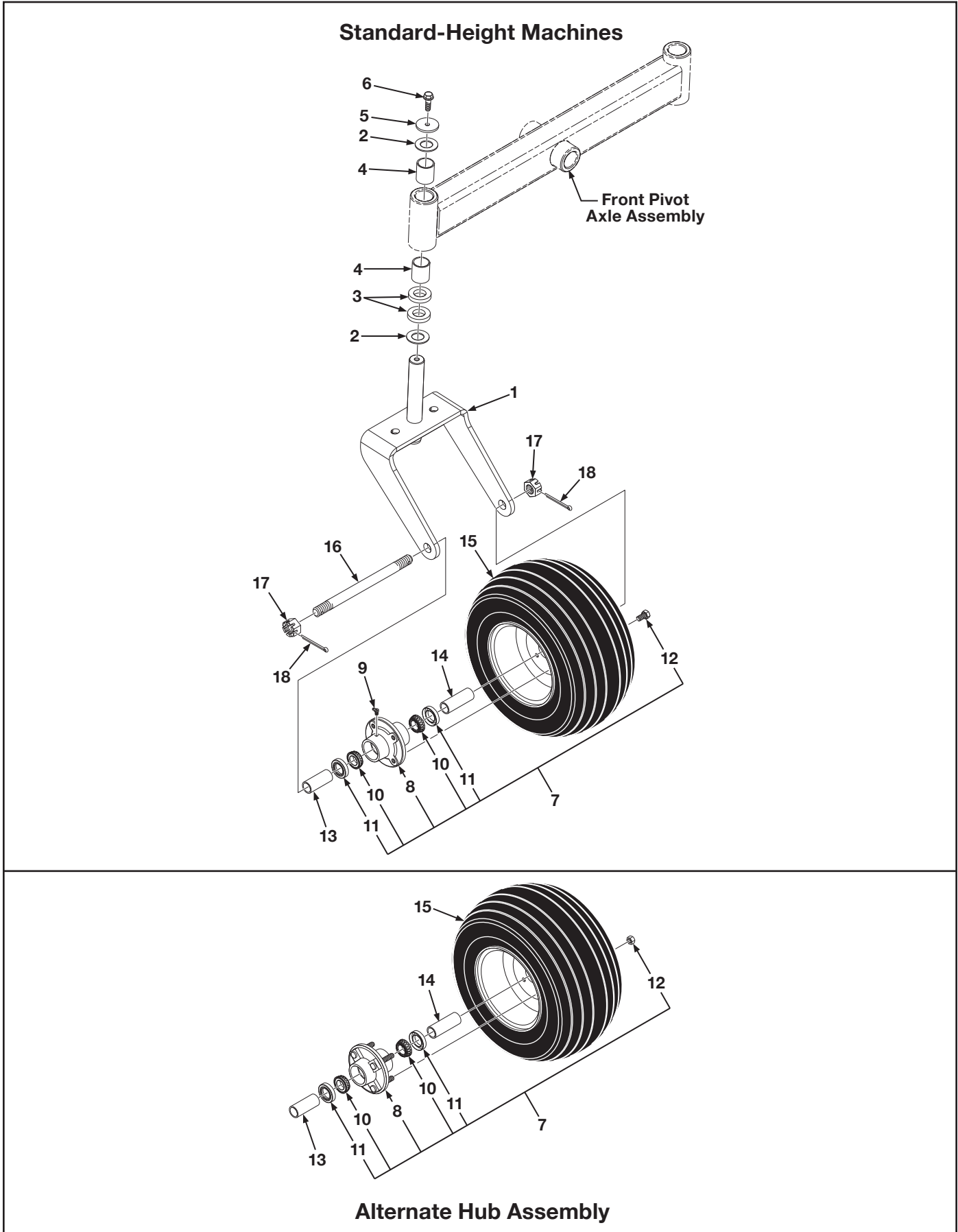

PARTS ILLUSTRATIONS

Figure 8-3. Caster Fork and Wheel

Item	Part No.	Qty	Description
1	315-548-010	2	Fork, Caster, Extended
2	000-155-013	2	Bushing, Washer, 2-3/4" OD x 1-1/2" ID x 10 Gauge
3	315-568-005	4	Spacer, Caster, 2-3/4" OD x 1-1/2" ID x 1/2" Thick
4	000-176-171	4	Bushing, Wheel Frame, 1-3/4" OD x 1-1/2" ID x 1-1/2" Long
5	000-155-004	2	Washer, Flat, 2-3/4" OD x 17/32" ID x 1/4" Thick
6	000-150-375	2	Bolt, Serrated Flange, 1/2"-13UNC x 1-1/4" Long
7	001-001-069	2	Hub Assembly, Includes Items 8 thru 12
8	001-001-074	1	Hub, Wheel, With Outer Race, Includes Item 9
9	NSS	1	Fitting, Grease, 65°
10	000-176-184	2	Bearing, Roller, Tapered, 1" Dia. Bore
11	000-166-457	2	Seal, Grease, 2" OD x 1-1/4" ID
12	000-150-218	4	Bolt, Lug, 1/2"-20UNF x 1-1/4" Long
13	315-598-000	2	Spacer, Wheel Bearing, Long
14	315-597-000	2	Spacer, Wheel Bearing, Short
15	001-001-057	2	Wheel/Tire, Foam-Filled, 18.5/8.50-8
16	315-553-000	2	Axle, Caster, 1-1/4" -14UNF x 12-1/2" Long
17	000-158-193	4	Nut, Castle, 1"-14UNF
18	000-161-078	4	Pin, Cotter, 1/8" Dia. x 2" Long

AR - As Required NSS - Not Serviced Separately ASN - After Serial No. BSN - Before Serial No. LP - Local Purchase

PARTS ILLUSTRATIONS

Figure 8-4. Hydraulics & Related Parts

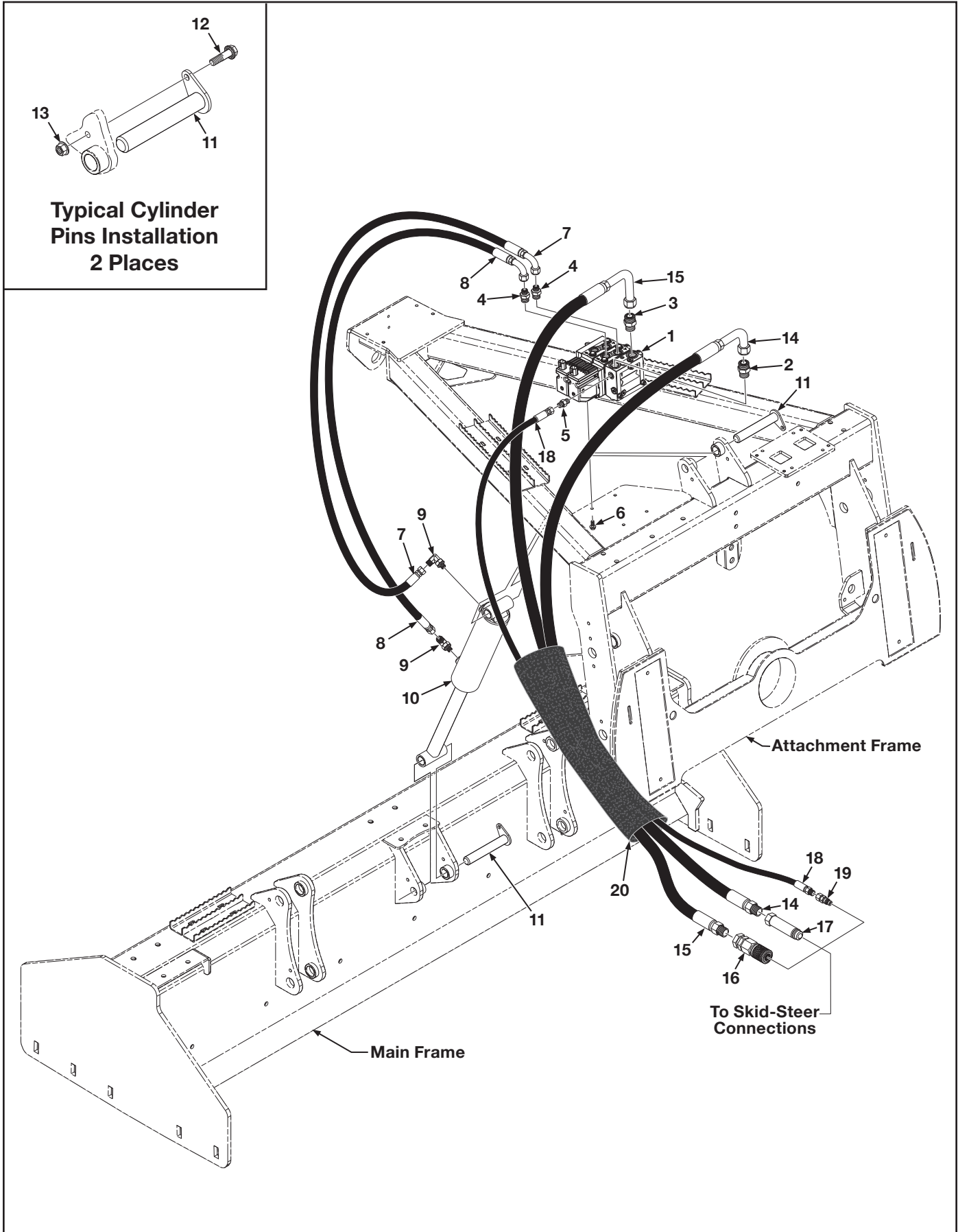

PARTS ILLUSTRATIONS

Figure 8-4. Hydraulics & Related Parts

Item	Part No.	Qty	Description
1	000-166-812	1	Valve Assembly, Hydraulic, PVE32H, Includes Items 2 thru 6
2	NSS	1	Valve, Check (DO NOT REMOVE FROM ITEM 1)
3	000-166-694	1	Fitting, Adapter, Straight, 12OFS x 12MB (FS6400-12-12)
4	000-166-699	2	Fitting, Adapter, Straight, 6OFS x 10MB (FS6400-06-10)
5	000-166-798	1	Fitting, Adapter, 06OFS x 05MB
6	000-150-074	4	Bolt, Serrated Flange, 5/16"-18UNC x 3/4" Long
7	000-166-736	1	Hose Assembly, 3/8" Dia x 26" Long x 6FFX x 6FFX90L, 3,000 PSI
8	100-166-736	1	Hose Assembly, 3/8" Dia x 26" Long x 6FFX x 6FFX90L, 3,000 PSI
9	000-166-697	2	Elbow, 90°, 6OFS x 6MB
10	000-166-690	1	Cylinder, Hydraulic, 3" Bore x 8" Stroke
11	000-161-169	2	Pin, Pivot, 1" Dia. x 6-7/8" Long
12	000-150-078	2	Bolt, Serrated Flange, 5/16"-18UNC x 1" Long
13	000-158-223	2	Nut, Lock, Flange, 5/16"-18UNC
14	000-166-734	1	Hose, 3/4" Dia. x 70" Long x 12MB x 12FFX90, 4,060 PSI
15	000-166-735	1	Hose, 3/4" Dia. x 74" Long x 12MB x 12FFX90L, 4,060 PSI
16	000-166-069	1	Coupler, Quick Disconnect, Flat Face, Female - 1/2" (Pressure Line)
17	000-166-676	1	Coupler, Quick Disconnect, Flat Face, Male -1/2" (Tank Line)
18	000-166-795	1	Hose Assembly, 3/8" Dia x 70" Long x 6FFX x 8MB, 3,000 PSI
19	000-166-797	1	Coupler, Quick Disconnect, Flat Face, Female - 3/8"
20	000-166-811	1	Sleeve, Nylon, Hydraulic Hoses
			BH-Bulkhead MP-Male Pipe FP-Female Pipe FPX-Female Pipe Swivel FFX- Female O-Ring Flat Face Swivel MB-Male O-Ring Boss FB-Female O-Ring Boss MJ-Male JIC FJ-Female JIC FJX-Female JIC Swivel OFS-O-Ring Face Seal OFSBH-O-Ring Face Seal Bulkhead

AR - As Required NSS - Not Serviced Separately ASN - After Serial No. BSN - Before Serial No. LP - Local Purchase

PARTS ILLUSTRATIONS

Figure 8-5. Hydraulic Valve Assembly

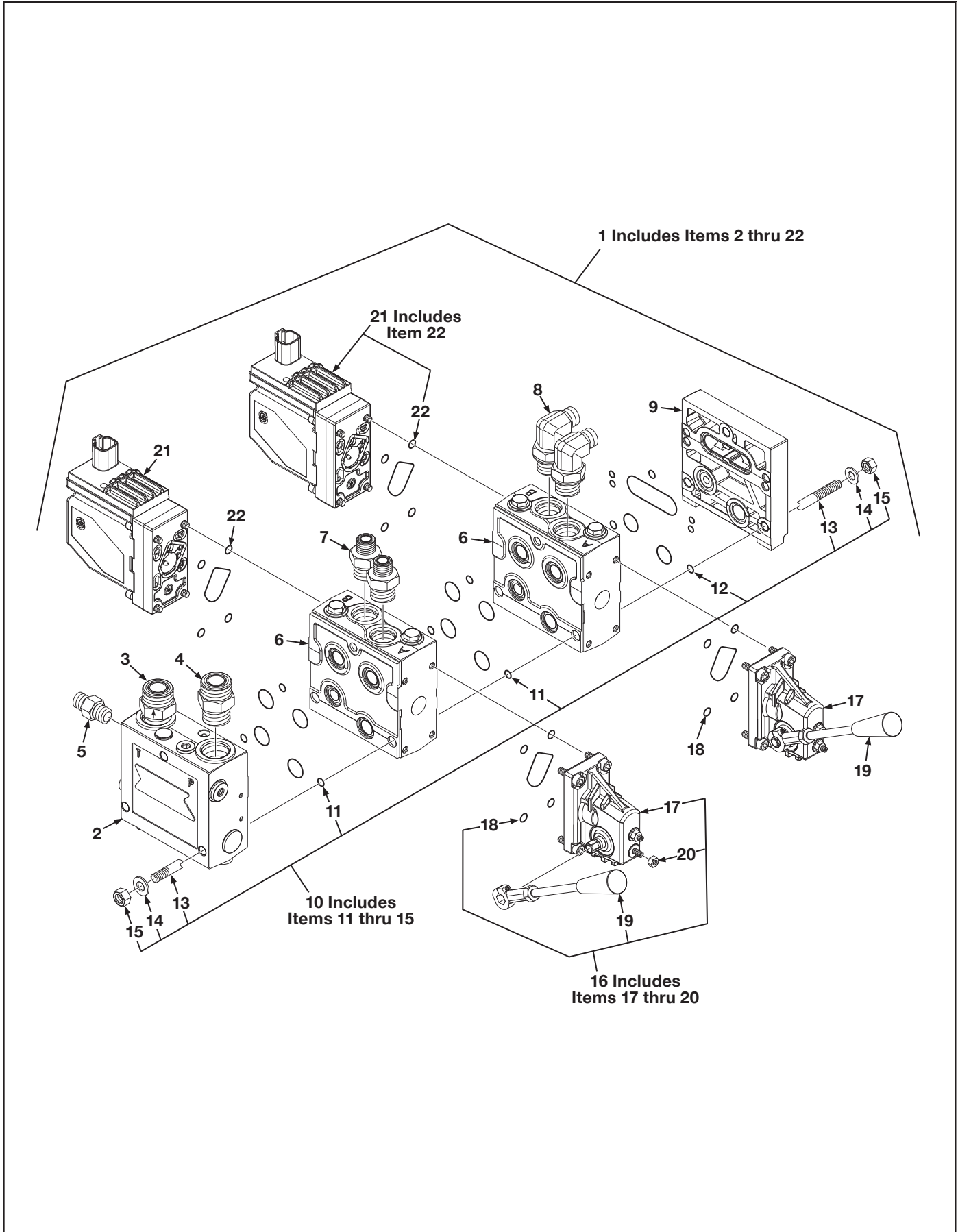

PARTS ILLUSTRATIONS

Figure 8-5. Hydraulic Valve Assembly

Item	Part No.	Qty	Description
1	000-166-812	1	Valve Assembly, Hydraulic, PVE32H, Includes Items 2 thru 22
2	NSS	1	Inlet, PVG32
3	NSS	1	Valve, Check (DO NOT REMOVE FROM ITEM 2) 000-166-824
4	000-166-694	1	Fitting, Adapter, Straight, 12OFS x 12MB (FS6400-12-12)
5	000-166-798	1	Fitting, Adapter, 06OFS x 05MB
6	NSS	2	Module, Work Section
7	000-166-699	2	Fitting, Adapter, Straight, 6OFS x 10MB (FS6400-06-10)
8	000-166-698	2	Elbow, 90°, 6OFS x 10MB (FS6801-06-10)
9	NSS	1	End Plate
10	000-166-782	1	Kit, Tie-Rod, Includes Items 11 thru 15
11	NSS	2	Seals
12	000-166-775	1	Kit, Seal, End Plate
13	NSS	3	Tie Rods
14	NSS	6	Washer
15	NSS	6	Nut
16	000-166-799	2	Kit, Handle Assembly & Housing, Includes Items 17 thru 20
17	NSS	2	Housing, Activation, Mechanical
18	000-166-820	2	Kit, Seal, Mechanical Activation
19	000-166-774	1	Handle Assembly
20	000-166-834	4	Nut
21	000-166-823	2	Electrical Coil, Includes Item 22
22	000-166-789	2	Kit, Seal, Danfoss PVEH Coil

AR - As Required NSS - Not Serviced Separately ASN - After Serial No. BSN - Before Serial No. LP - Local Purchase

PARTS ILLUSTRATIONS

Figure 8-6. Hydraulics Slope Cylinder, Fittings and Related Parts

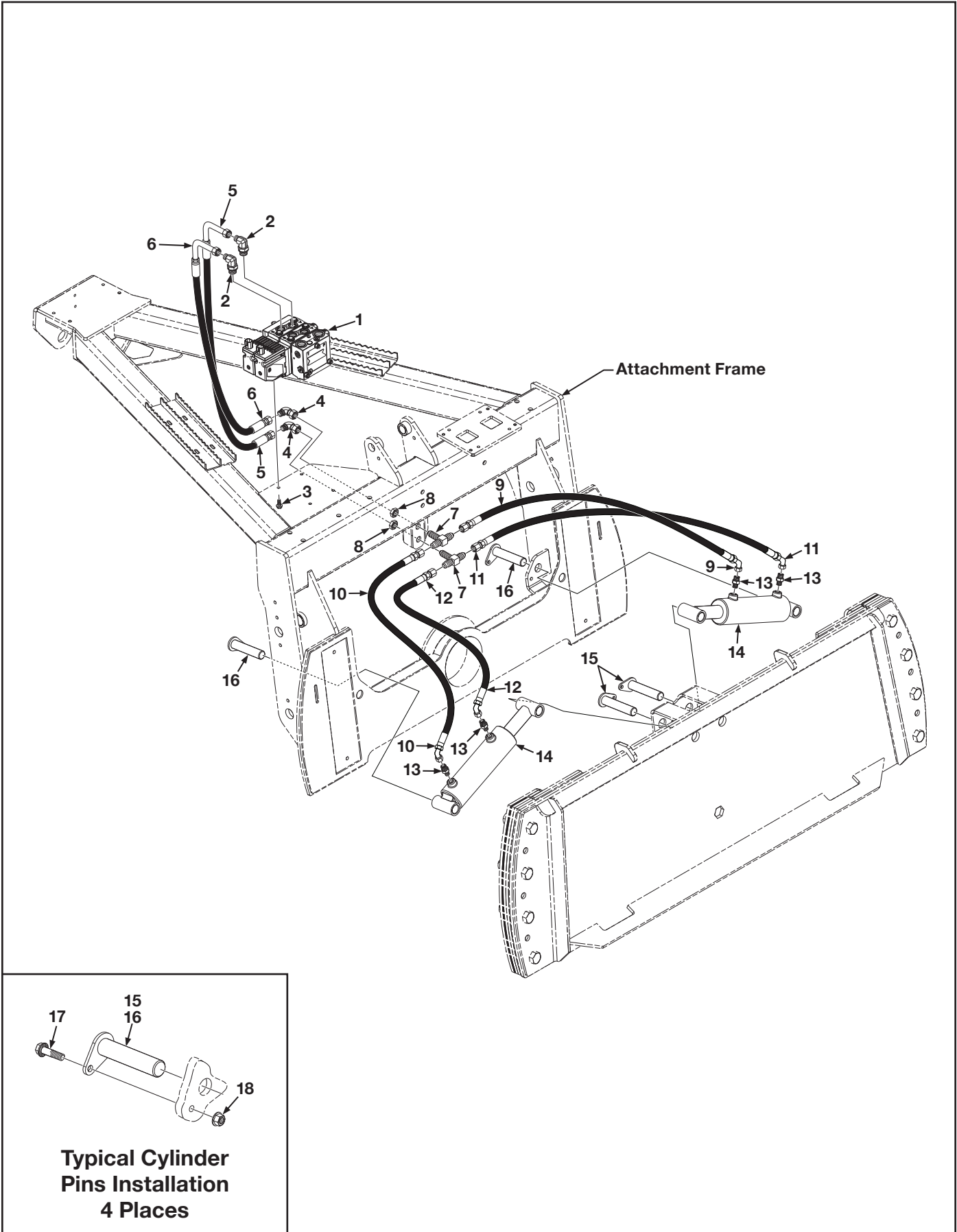

PARTS ILLUSTRATIONS

Figure 8-6. Hydraulics Slope Cylinder, Fittings and Related Parts

Item	Part No.	Qty	Description
1	000-166-812	1	Valve Assembly, Hydraulic, PVE32H, Includes Items 2 thru 3
2	000-166-698	2	Elbow, 90°, 6OFS x 10MB (FS6801-06-10)
3	000-150-074	4	Bolt, Serrated Flange, 5/16"-18UNC x 3/4" Long
4	000-166-738	2	Fitting, Elbow, 90°, 6OFS x 6FOFX
5	000-166-736	1	Hose Assembly, 3/8" Dia x 26" Long x 6FFX x 6FFX90L, 3,000 PSI
6	000-166-736	1	Hose Assembly, 3/8" Dia x 26" Long x 6FFX x 6FFX90L, 3,000 PSI
7	000-166-695	2	Fitting, Tee, Bulkhead Branch, 6OFS x 6OFS x 6OFSBH, Includes Item 8
8	NSS	2	Nut, Hex, Lock
9	000-166-737	1	Hose Assembly, 3/8" Dia. x 20" Long, 6FFX x 6FXX45, 3,000 PSI
10	000-166-737	1	Hose Assembly, 3/8" Dia. x 20" Long, 6FFX x 6FXX45, 3,000 PSI
11	000-166-737	1	Hose Assembly, 3/8" Dia. x 20" Long, 6FFX x 6FXX45, 3,000 PSI
12	000-166-737	1	Hose Assembly, 3/8" Dia. x 20" Long, 6FFX x 6FXX45, 3,000 PSI
13	000-166-685	4	Adapter, Straight, 6OFS x 6MB
14	000-166-680	2	Cylinder, Hydraulic, 2-1/2" Bore x 6" Stroke
15	000-161-164	2	Pin, Pivot, 1" Dia. x 5" Long
16	000-161-168	2	Pin, Pivot, 1" Dia. x 4-5/8" Long
17	000-150-078	4	Bolt, Serrated Flange, 5/16"-18UNC x 1" Long
18	000-158-223	4	Nut, Lock, Flange, 5/16"-18UNC
			BH-Bulkhead MP-Male Pipe FP-Female Pipe FPX-Female Pipe Swivel FFX- Female O-Ring Flat Face Swivel MB-Male O-Ring Boss FB-Female O-Ring Boss MJ-Male JIC FJ-Female JIC FJX-Female JIC Swivel OFS-O-Ring Face Seal OFSBH-O-Ring Face Seal Bulkhead

AR - As Required NSS - Not Serviced Separately ASN - After Serial No. BSN - Before Serial No. LP - Local Purchase

PARTS ILLUSTRATIONS

Figure 8-7. Slope Frame, Shims and Related Parts

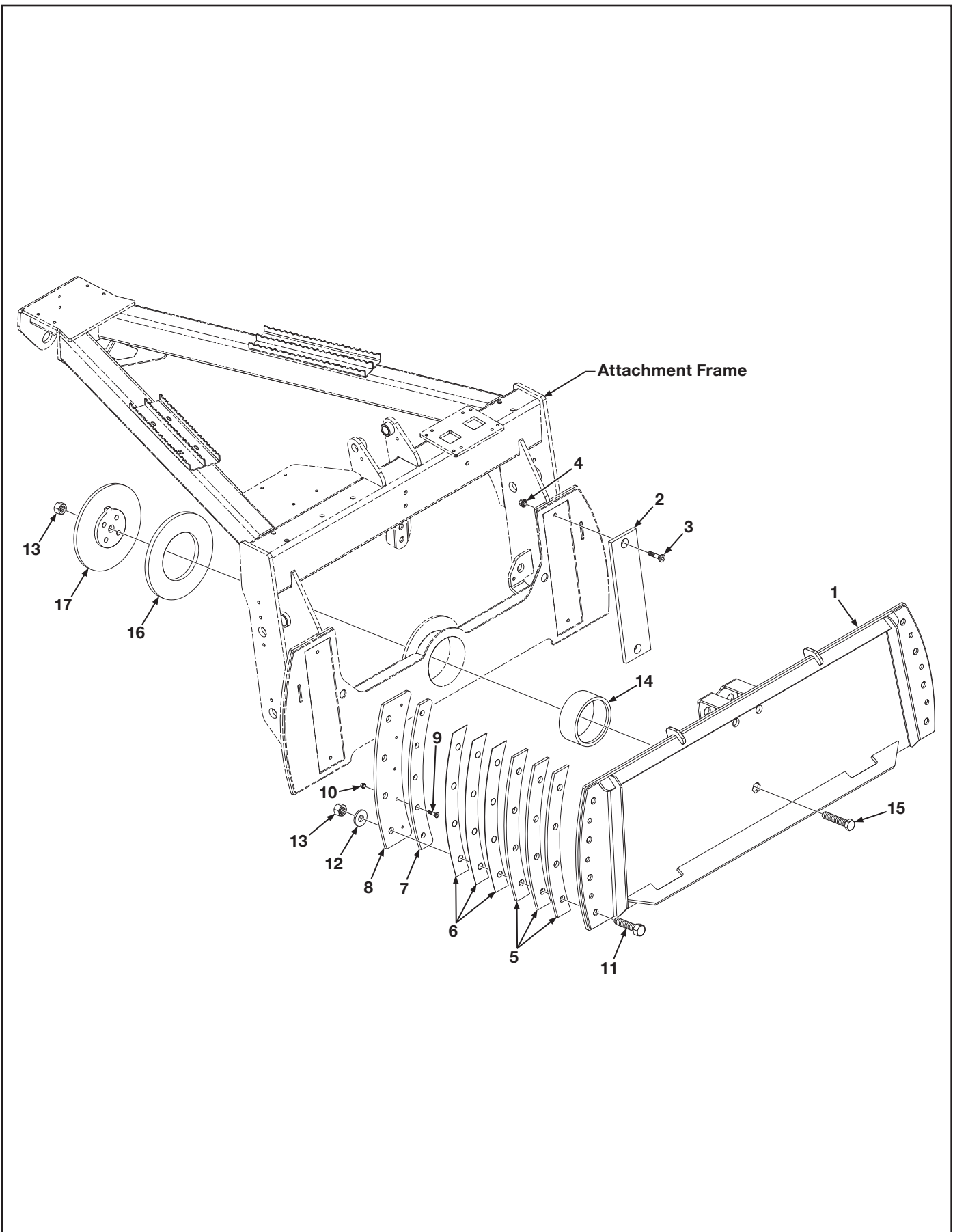

PARTS ILLUSTRATIONS

Figure 8-7. Slope Frame, Shims and Related Parts

Item	Part No.	Qty	Description
1	315-632-000	1	Frame, Slope
2	100-094-007	2	Pad, Main Slide, Green
3	000-150-130	4	Screw, Flat Head, Socket, 3/8"-16UNC x 1-1/4" Long
4	000-158-217	4	Nut, Serrated Flange, 3/8"-16UNC
5	100-094-002	AR	Shim, Retainer, 3/8"
6	100-094-003	AR	Shim, Retainer, 1/16"
7	100-094-005	1	Pad, Slide, Right (Shown)
	100-094-004	1	Pad, Slide, Left (Not Shown)
8	100-094-001	2	Plate, Slide Retainer
9	000-150-066	10	Screw, Flat Head, Socket, 1/4"-20UNC x 1" Long
10	000-158-048	10	Nut, Serrated Flange, 1/4"-20UNC
11	000-150-333	8	Bolt, Hex Head, 3/4"-16UNF x 3-1/2" Long
12	000-155-091	8	Washer, Flat, 3/4"
13	000-158-182	9	Nut, Hex, Nylon Lock, 3/4"-16UNF, (250 ft-lbs)
14	000-176-260	1	Bushing, Nylon, 5-1/2" OD x 5" ID x 2" Long
15	000-150-337	1	Bolt, Hex Head, 3/4"-16UNF x 5" Long
16	100-192-008	1	Disk, Slide
17	100-192-001	1	Cap, Pivot

AR - As Required NSS - Not Serviced Separately ASN - After Serial No. BSN - Before Serial No. LP - Local Purchase

PARTS ILLUSTRATIONS

Figure 8-8. Laser Controls and Related Parts - Trimble Earthworks Go!

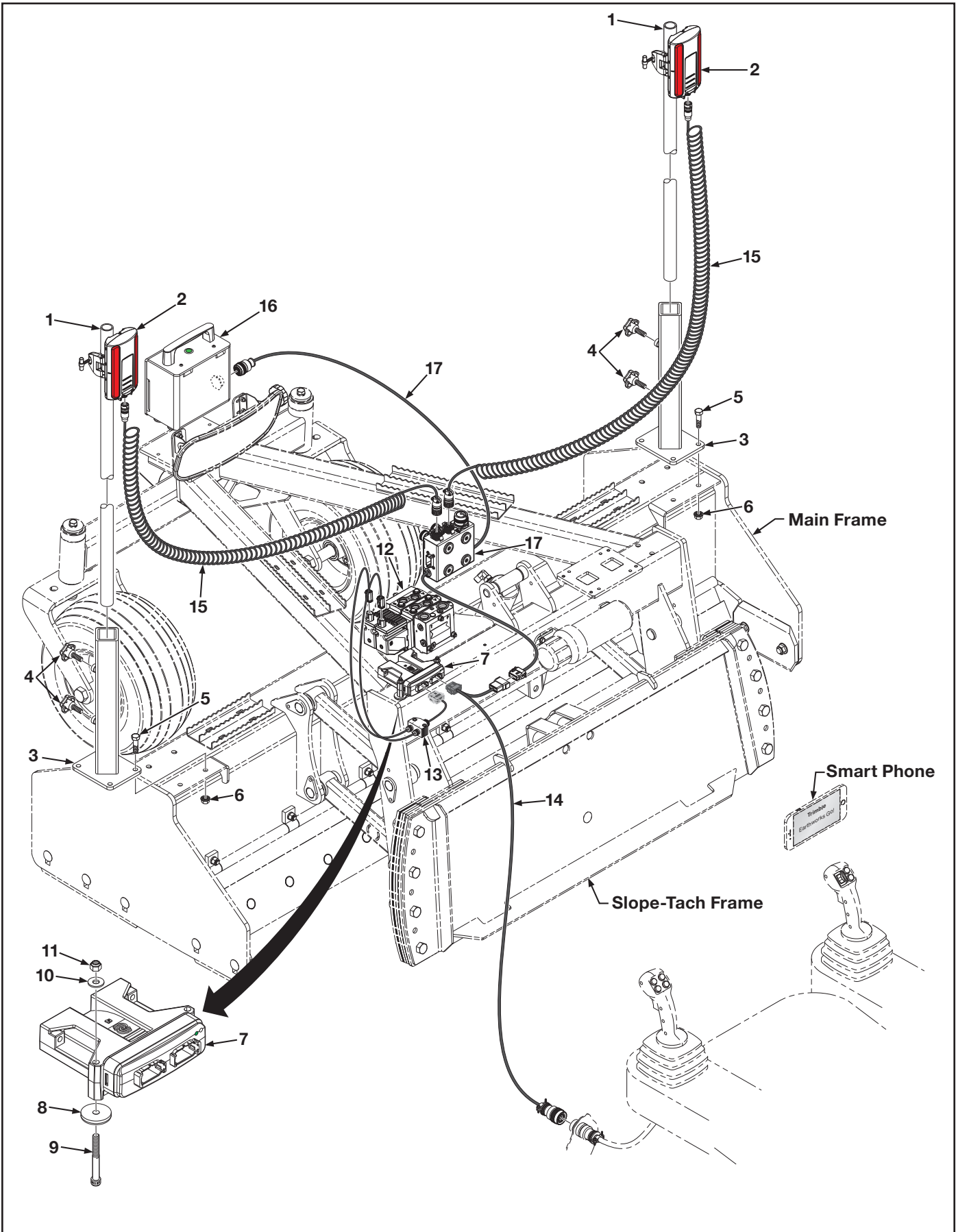

PARTS ILLUSTRATIONS

Figure 8-8. Laser Controls and Related Parts - Trimble Earthworks Go!

Item	Part No.	Qty	Description
1	001-001-146	2	Pole, Mast, Black, 1-3/4" Dia x 7' Long
2	000-200-472	2	Receiver, Laser 360°, Trimble
3	315-101-700	2	Mount, Mast Pole
4	001-001-180	4	Handle, Star Knob
5	000-150-375	8	Bolt, Hex Head, 1/2"-13UNC x 1-1/4" Long
6	000-158-111	8	Nut, Serrated Flange, 1/2"-13UNC
7	000-200-399	1	Module, Valve Control, Includes Items 8 thru 11
8	001-001-164	2	Magnet, Round, 1-1/4" Dia.
9	000-150-392	2	Bolt, Socket Head, #10-24UNC x 2-1/4" Long
10	000-155-016	2	Washer, Flat, #10 USS
11	000-158-026	2	Nut, Hex, Nylon Lock, #10-24UNC
12	000-166-812	1	Valve Assembly, Hydraulic, PVE32H
13	000-200-368	1	Cable, Valve Module, Dual
14		1	Harness, Loader (Machine Specific)
15	000-200-505	2	Cable, Receiver, Coiled
16	000-200-506	1	Go! Box, Trimble Earthworks, Includes Item 17
17	000-200-504	1	Box, Junction & Harness

AR - As Required NSS - Not Serviced Separately ASN - After Serial No. BSN - Before Serial No. LP - Local Purchase

PARTS ILLUSTRATIONS

Figure 8-9. Box, Laser Receiver 360°, Cables - Trimble Earthworks Go!

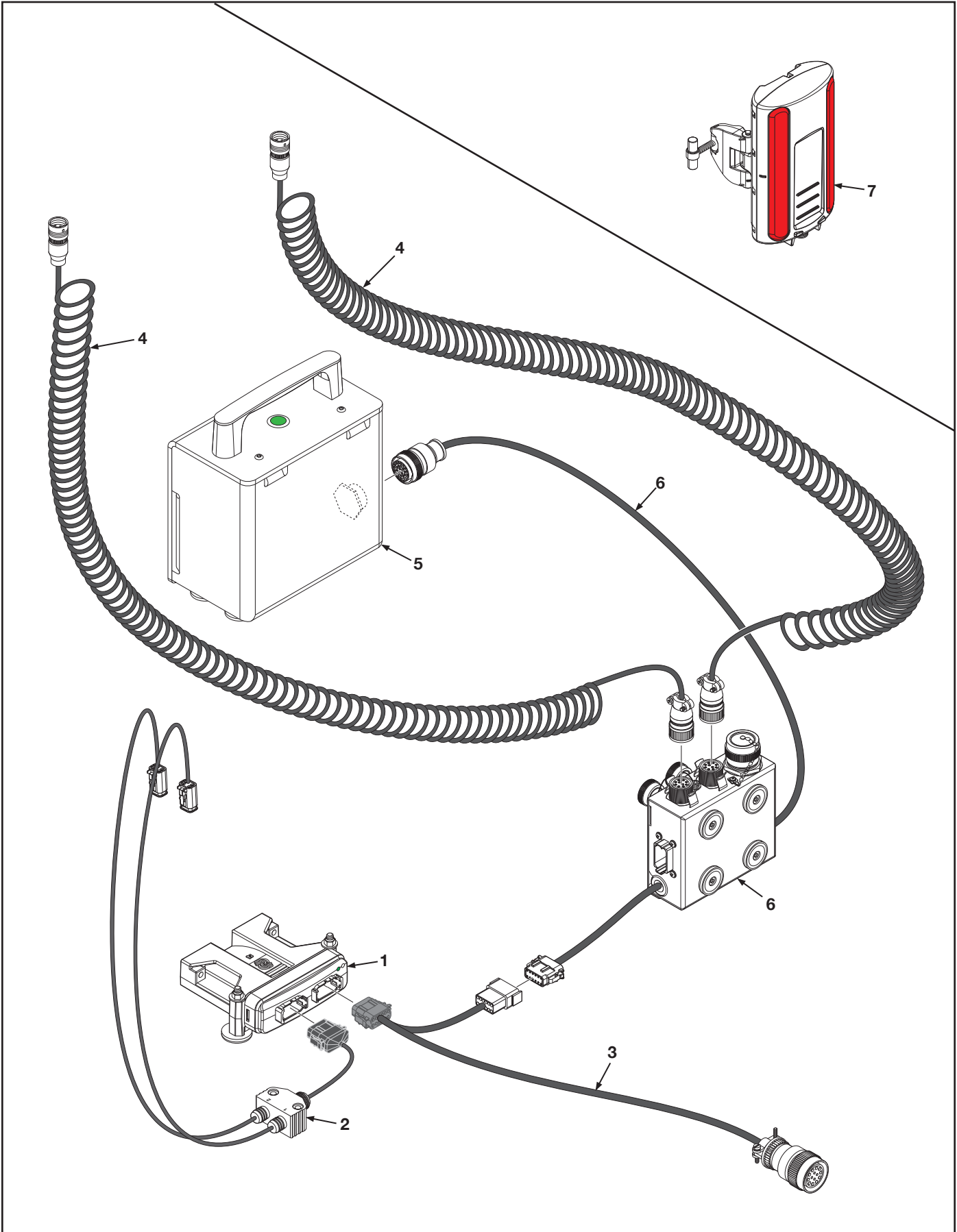

PARTS ILLUSTRATIONS

Figure 8-9. Box, Laser Receiver 360°, Cables - Trimble Earthworks Go!

Item	Part No.	Qty	Description
1	000-200-399	1	Module, Valve Control
2	000-200-368	1	Cable, Valve Module, Dual
3		1	Harness, Loader (Machine Specific)
4	000-200-505	2	Cable, Receiver, Coiled
5	000-200-506	1	Go! Box, Trimble Earthworks, Includes Item 6
6	000-200-504	1	Box, Junction & Harness
7	000-200-472	2	Receiver, Laser 360°, Trimble

AR - As Required NSS - Not Serviced Separately ASN - After Serial No. BSN - Before Serial No. LP - Local Purchase

PARTS ILLUSTRATIONS

Figure 8-10. Decals

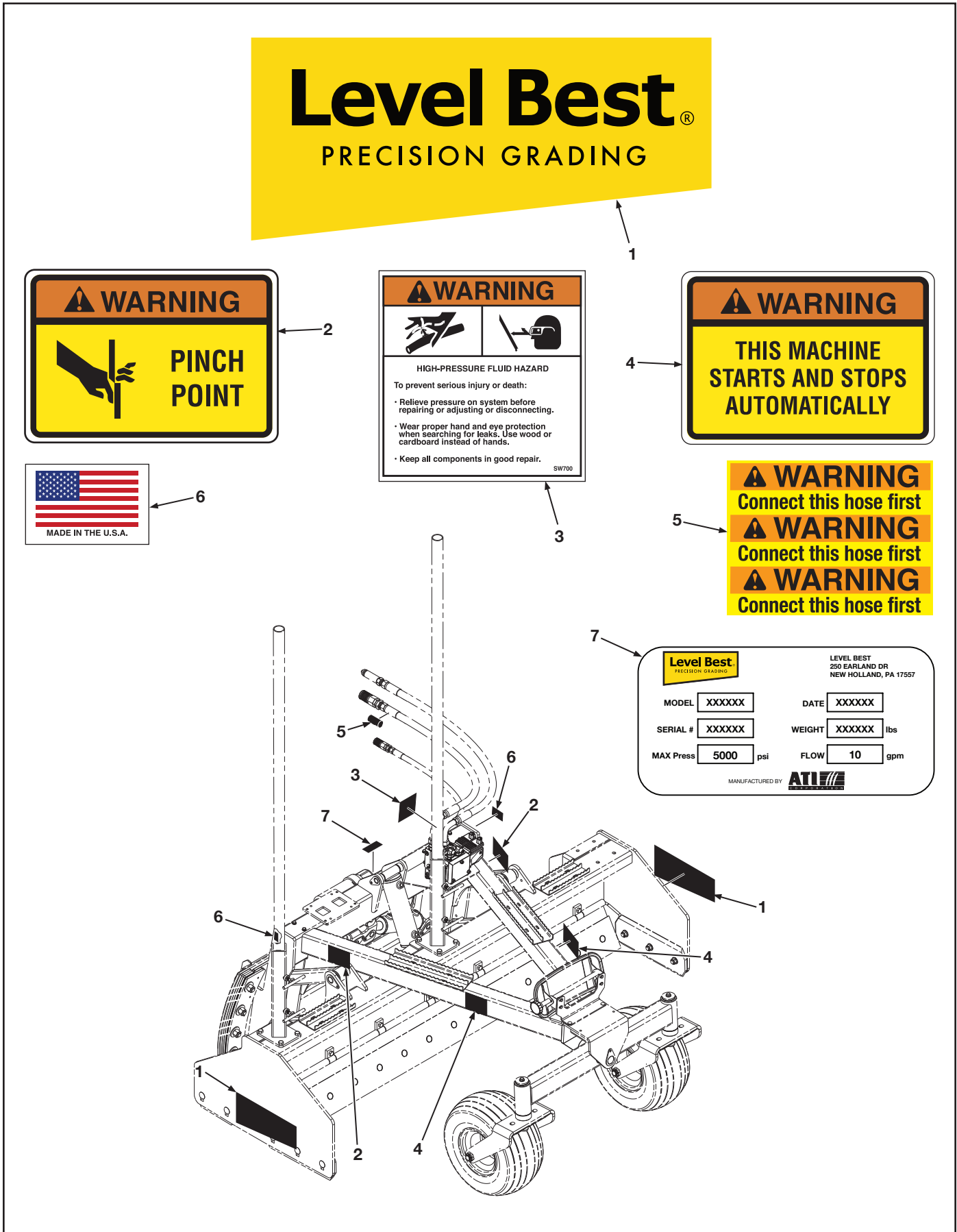

Level Best[®]
PRECISION GRADING

WARNING
PINCH POINT

WARNING

HIGH-PRESSURE FLUID HAZARD

To prevent serious injury or death:

- Relieve pressure on system before repairing or adjusting or disconnecting.
- Wear proper hand and eye protection when searching for leaks. Use wood or cardboard instead of hands.
- Keep all components in good repair.

SW700

WARNING
THIS MACHINE STARTS AND STOPS AUTOMATICALLY

MADE IN THE U.S.A.

WARNING
Connect this hose first

WARNING
Connect this hose first

WARNING
Connect this hose first

Level Best
PRECISION GRADING

LEVEL BEST
250 EARLAND DR
NEW HOLLAND, PA 17557

MODEL DATE

SERIAL # WEIGHT lbs

MAX Press psi FLOW gpm

MANUFACTURED BY **ATI**

PARTS ILLUSTRATIONS

Figure 8-10. Decals

Item	Part No.	Qty	Description
1	000-186-102	2	Decal, Level Best Logo
2	000-186-055	2	Decal, Danger, Pinch Point
3	000-186-041	1	Decal, Warning, High-Pressure
4	000-186-094	2	Decal, Danger, This Machine Starts & Stops Automatically
5	000-186-100	1	Decal, Warning, Connect Hose First
6	000-186-092	2	Decal, Made in U.S.A.
7	000-186-111	1	Plate, Model/Serial, Level Best

AR - As Required NSS - Not Serviced Separately ASN - After Serial No. BSN - Before Serial No. LP - Local Purchase

(for future use)

INDEX

A	
Attachment Frame and Related Parts	8.6
B	
Bobcat Joystick Functions	2.1
C	
Cables and Hoses	6.1
Case Joystick Functions	2.4, 2.5
Caster Fork and Wheel	8.8
Cat D-Series Joystick Functions	2.1
Cleaning - Para Level	6.1
Cleaning - Vacuum Cup	6.5
CNH Joystick Functions 550-Series	2.4
CNH Joystick Functions B-Series	2.4
D	
Decals	8.22
Dimensions	6.1
Disclaimer	i
E	
Equipment Setup	2.1
G	
General Arrangement for Integrated Machine Harness..	3.2, 4.2, 5.2
General Arrangement Universal Joystick	3.4, 4.4
H	
How To Order Parts	8.2
Hub Greasing Instructions	6.3
Hydraulic Hose Connections to Skid Steer	6.4
Hydraulics	6.4
Hydraulics & Related Parts	8.10
Hydraulics Slope Cylinder, Fittings and Related Parts .	8.14
Hydraulic Valve	6.4
Hydraulic Valve Assembly	8.12
I	
Index	9.1
Installation - Vacuum Cup	6.5
J	
JCB/Volvo Joystick Functions	2.6
John Deere E-Series Joystick Functions	2.2
John Deere G-Series Joystick Functions	2.2
Joystick Controls	2.1
Joystick with Cable	3.7, 4.7
K	
Kubota SSV65 & 75 Joystick Functions	2.3
Kubota SVL 95 S6699 Multifunction Controller Kit	2.3
L	
Laser Controls and Related Parts - Trimble Earthworks Go!	8.18
Level Best Joystick Harness	3.7, 4.7
List of Illustrations	iv
List of Parts Illustrations	8.3
Loader Hydraulics	6.2
Loader Joystick Functions	2.1
M	
Lube and Maintenance Chart	6.3
Machine - Para Level	6.1
Main Frame and Cutting Edges	8.4
Maintenance	6.1
Maintenance Service - Vacuum Cup	6.5
Module Controller	3.6, 4.6
Mustang/Gehl Joystick Functions	2.7
N	
New Holland Joystick Functions	2.5
O	
Overview	1.1
P	
Parts Illustrations	8.1
PD Series Hydraulic Valve	6.1
R	
Release - Vacuum Cup	6.5
S	
Safety Information	vii
Safety Precaution Definitions	vii
Serial Number Information	8.2
Service	6.2
Shims and Slide Pads	6.2
Slope Frame, Shims and Related Parts	8.16
Specifications	6.1
Specifications and Maintenance	6.1
Storage and Transport	6.1
Storage - Vacuum Cup	6.5
Systems Features and Basic Operation	1.1
T	
Table of Contents	iii
Takeuchi TL12/TL250 Joystick Functions	2.6
Topcon 3DMC	3.1
Topcon System 5	4.1
Trimble Cable to Module Controller	3.7, 4.7
Trimble Earthworks go	5.1
Troubleshooting	7.1
U	
Using this document	i
V	
Vacuum Cup	6.5
Valve Module Cable	3.6, 4.6
W	
Warranty	vi
Where To Get Parts And Service	8.2

(for future use)

